



High-Pressure Coriolis Mass Flow Meter

TMU-W

Installation and operation manual



Please read the instructions carefully and store them in a safe place

Contents

INTRODUCTION	5
I. Shipping and storage; product inspection	5
II. Warranty	5
III. Maintenance, Repair and Hazardous substances	5
IV. Disposal	5
V. Supplementary operating instructions.....	5
VI. Operating manual of explosion-proof flowmeters	5
1. IDENTIFICATION.....	6
2. STEPS PRIOR TO OPERATION.....	7
2.1 Safety advisory for the user	8
2.2 Hazard warnings	8
2.3 Proper use of the device	9
2.4 Installation and servicing	9
2.5 Returning your flowmeter for servicing or calibration	10
2.6 Replacement of the transmitter electronics.....	10
2.7 Maintenance.....	11
2.7.1 Transmitter.....	11
2.7.2 Coriolis mass flow sensor	11
3. THE TMU-W SENSOR	12
3.1 Application domain of the TMU-W sensor	12
3.2 Mode of operation.....	12
3.2.1 Measuring principle	12
3.2.2 System configuration	12
3.2.3 Acquisition.....	12
3.3 Performance characteristics of the TMU-W sensor	13
3.3.1 Reference conditions	13
3.3.2 TMU-W flow ranges	13
3.3.3 Density measurement	13
3.3.4 Accuracy	14
3.3.5 Pressure loss in Hydrogen dispensers	14
3.3.6 Environmental Conditions.....	14
3.4 Operating conditions	15
3.4.1 Installation.....	15
3.4.2 Installation Orientation	16
3.4.3 Pressure surges	18
3.4.4 Using the device with hazardous fluids.....	18
3.4.5 Vibration stability	18
3.4.6 Process conditions.....	19
3.4.7 Gas content	19
3.4.8 Process pressure range	19
3.4.9 Outlet pressure	19
3.4.10 Connection to the transmitter	19
3.5 Construction details.....	20
3.5.1 Installation lengths and weight	20
3.5.2 Dimension drawing for the type TMU-W004.....	20
3.5.3 Dimension drawing for the type TMU-W006.....	21
3.5.4 Dimension drawing for the type TMU-W012.....	21
3.5.5 Materials	21

4.	UMC4 TRANSMITTER	22
4.1	Application domain of the UMC4 transmitter	22
4.2	Mode of Operation	22
4.3	System configuration	22
4.4	UMC4 performance characteristics	22
4.4.1	Reference conditions	22
4.4.2	Measured error	22
4.4.3	Repeatability error	22
4.4.4	Influence of ambient temperature.....	22
4.5	Operating conditions	23
4.5.1	Installation conditions and cable glands	23
4.5.2	NPT cable glands	23
4.5.3	Environmental conditions	24
4.5.4	Process conditions.....	25
4.6	DSB data memory module	25
4.7	Input measured variables	26
4.7.1	Measured Values.....	26
4.7.2	Measuring range	26
4.8	Outputs	27
4.8.1	Output circuits.....	27
4.8.2	Current outputs.....	28
4.8.3	Binary Outputs	29
4.9	Construction details UMC4	30
4.9.1	Mounting / Dimensions.....	30
4.9.2	Weight	32
4.9.3	Material.....	32
4.10	Construction details UMC4-RM.....	33
4.10.1	Dimensions.....	33
4.10.2	Mounting bore pattern	34
4.10.3	Weight.....	34
4.10.4	Materials	34
5.	ELECTRICAL CONNECTIONS UMC4.....	35
5.1	Mains connections and their protection classes.....	35
5.1.1	Wiring diagrams	35
5.1.2	The output terminals.....	36
5.1.3	Sensor connection.....	36
6.	CERTIFICATES AND APPROVALS	41
6.1	Conformity to CE Directives	41
6.2	Explosion protection	41
6.3	Custody transfer applications	41
6.4	Patents	41

7.	OPERATION.....	42
7.1	Control unit BE4.....	42
7.1.1	Introduction	42
7.1.2	Operating modes.....	43
7.1.3	Operator interface	43
7.1.4	The keys and their functions	44
7.1.5	Functional classes, functions and parameters	45
7.1.6	Display	46
7.2	UMC4 transmitter functional classes	47
7.2.1	MEASURED VALUES functional class	48
7.2.2	PASSWORD functional class	53
7.2.3	COUNTER functional class	55
7.2.4	MEASUREMENT PROCESSING functional class.....	57
7.2.5	FLOW functional class	61
7.2.6	DENSITY functional class	66
7.2.7	TEMPERATURE functional class.....	73
7.2.8	PULSE OUTPUT functional class	76
7.2.9	STATUS functional class.....	79
7.2.10	CURRENT OUTPUTS functional class	82
7.2.11	SIMULATION functional class	87
7.2.12	SELF-TEST functional class.....	91
7.2.13	UMC4 TRANSMITTER SETTINGS functional class	94
7.2.14	SENSOR SETTINGS functional class.....	97
7.2.15	CUSTODY TRANSFER functional class	100
7.3	Density calibration.....	105
7.3.1	Conditions	105
7.3.2	Procedure.....	105
8.	TROUBLE SHOOTING.....	107
8.1	Self-help Checklist.....	107
8.2	UMC4 transmitter error messages	108
8.2.1	Standard operating mode	108
8.2.2	Custody transfer mode.....	108
8.2.3	List of error messages	109
8.3	Returning the Meter	113
8.3.1	Declaration of Decontamination	114
9.	DECLARATION OF CONFORMITY	115

Introduction

I. Shipping and storage; product inspection

Shipping and storage

The device is to be safeguarded against dampness, contamination (especially the inside of the flow meter), impact and damage. Open the packaging with caution to prevent unintentional damage.

Adhere to the temperature limits during storage.

Product inspection

Upon receipt of the product, check the contents of the box and the product particulars against the information on the delivery slip and order form so as to ensure that all ordered components have been supplied. Notify us of any shipping damage immediately upon receipt of the product. Any damage claim received at a later time will not be honoured.

II. Warranty

Your flowmeter was manufactured in accordance with the highest quality standards and was thoroughly tested prior to shipment. However, in the event any problem arises with your device, we will be happy to resolve the problem for you as quickly as possible under the terms of the warranty, which can be found in the terms and conditions of delivery. Your warranty will only be honoured if the device was installed and operated in accordance with the instructions for your device. Any mounting, commissioning and/or maintenance work is to be carried out by qualified and authorized technicians only.

III. Maintenance, Repair and Hazardous substances

When used in the intended manner no special maintenance is required. However, the flowmeter should be checked within the context of routine maintenance of the facility and the pipelines. Should a repair, calibration or maintenance become necessary, be sure to clean the device thoroughly and follow the steps in section O, "Returning the Meter" before returning the device to Heinrichs Messtechnik.

The operator is liable for any substance removal or personal damage costs arising from inadequate cleaning of a device sent for repair.

IV. Disposal

Observe the regulations applicable to disposal in the country of installation!

V. Supplementary operating instructions

Supplement operating manuals are available for special features, interfaces and operations relating to your device, request your copy from our service department.

VI. Operating manual of explosion-proof flowmeters

For installation of the flowmeter within hazardous areas read the operation manual of explosion-proof flowmeters. It contains all the EX-relevant information for your flowmeter.



Warning!

Only devices designated as EX-certified on their rating plates may be used in areas of potentially explosive atmospheres!

The use of standard equipment in EX-hazardous areas is strictly prohibited.

1. Identification

Manufacturer: Heinrichs Messtechnik GmbH
Robert-Perthel-Strasse 9
D-50739 Cologne
Germany

KOBOLD Instruments Inc.
1801 Parkway View Drive
Pittsburgh PA 15205-1422



Phone: +49 221 49708-0
Fax: +49 221 49708-178

Tel.: 412-788-2830
Fax: 412-788-4980



Internet: www.heinrichs.eu
Email: info@heinrichs.eu

www.koboldusa.com
info@koboldusa.com

Product type: Mass flow-rate meter for liquid and gaseous products under high pressure

Product name: Sensor type: TMU-W
Transmitter type: UMC4 or UMC4-RM

File name: tmu-w_umc4_ba_20.02_en.docx

Version.: 20.02, dated November 5, 2020

2. Steps prior to operation



It is essential that you read these operating instructions before installing and operating the device. The device is to be installed and serviced by a qualified technician only. The UMC4 transmitter is to be used exclusively to measure mass and volume flow, as well as liquid and gas density and temperature, in conjunction with a Heinrichs Messtechnik TM, TME, TMR, TMU, TM-SH or HPC sensor.

Downloading of the present document from our web site www.heinrichs.eu and printing out this document is allowed only for the purposes of using our mass flowmeters. All rights reserved. No instructions, wiring diagrams, and/or supplied software, or any portion thereof, may be produced, stored, in a retrieval system or transmitted by any means, electronic, mechanical, photocopying or otherwise, without the prior written permission of Heinrichs Messtechnik GmbH.

Although the materials in the present document were prepared with extreme care, errors cannot be ruled out. Hence, neither the company, the programmer nor the author can be held legally or otherwise responsible for any erroneous information and/or any loss or damage arising from the use of the information enclosed.

Heinrichs Messtechnik GmbH extends no express or implied warranty in regard to the applicability of the present document for any purpose other than that described.

We plan to optimize and improve the products described and in so doing will incorporate not only our own ideas but also, and in particular, any suggestions for improvement made by our customers. If you feel that there is any way in which our products could be improved, please send your suggestions to the following address:

Company:

Heinrichs Messtechnik GmbH
HM-EE (R&D Department)
Robert-Perthel-Strasse 9
D-50739 Cologne
Germany
or:

KOBOLD Instruments Inc.
1801 Parkway View Drive
Pittsburgh PA 15205-1422



via fax : +49 (221) 49708-178

Tel.: 412-788-2830
Fax: 412-788-4980



via email: info@heinrichs.eu

www.koboldusa.com
info@koboldusa.com

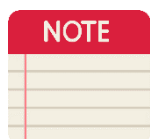

Note:

We reserve the right to change the technical data in this manual in the light of any technical progress that might be made.

For updates regarding this product, visit our website at www.heinrichs.eu, where you will also find contact information for the Heinrichs Messtechnik distributor nearest you. For information regarding our own sales operations, contact us at info@heinrichs.eu.

2.1 Safety advisory for the user

The present document contains the information that you need in order to operate the product described herein properly. This document is intended for use by qualified personnel. This means personnel who are qualified to operate the device described herein safely, including

- electronics engineers,
- electrical engineers, or
- service technicians

who are conversant with the safety regulations pertaining to the use of electrical and automated technical devices and with the applicable laws and regulations in their own country.

Such personnel must be authorized by the facility operator to install, commission and service the product described herein, and must have read and understood the contents of this operating instructions before working with the device.

2.2 Hazard warnings

The purpose of the hazard warnings listed below is to ensure that device operators and maintenance personnel are not injured and that the flow meter and any devices connected to it are not damaged.

The safety advisories and hazard warnings in the present document that aim to avoid placing operators and maintenance personnel at risk and to avoid material damage are prioritized using the terms listed below, which are defined as follows in regard to these instructions herein and the advisories pertaining to the device itself.

Warning



means that failure to take the prescribed precautions **could result** in injury, substantial material damage or even death. Always comply to these warnings and proceed with caution.

Caution



means that failure to take the prescribed precaution **could result** in material damage or destruction of the device. We advice always to abide to these instructions!

Note



means that the accompanying text contains important information about the product, handling the product or about a section of the documentation that is of particular importance.

2.3 Proper use of the device

The Coriolis Mass Flow Sensor is intended for the sole use of direct and continuous mass flow measurement of liquids and gases.

To ensure safety for people and the environment adhere to the installation and operational instructions and warning in this manual



Warning

The operator is responsible for ensuring that the material used in the sensor and housing are suitable and that such material meets the requirements for the process medium and the ambient site conditions.

The manufacturer accepts no responsibility for the selection of unsuitable materials.



Warning

Only sensors marked as EX-certified on their rating plates may be used in EX hazardous locations. Standard equipment is not permitted for installation and use in EX hazardous locations.

For installation within hazardous areas read the Ex-supplementary manual. It contains all EX-relevant parameters for the sensor and the UMC4 transmitter.



Caution

To ensure the device performs correctly and safely, it must be shipped, stored, set up, mounted, operated and maintained correctly.

2.4 Installation and servicing

The devices described in this manual are to be installed and serviced only by qualified technical personnel such as a qualified Heinrichs Messtechnik electronics engineer or service technician.



Warning

Before servicing, the device must be completely de-energised and disconnected from all peripheral devices. The technician must also ensure that the device is completely disconnected from any live circuits.

Only original replacement parts are to be used.

Heinrichs Messtechnik GmbH accepts no liability for any loss or damage of any kind arising from improper operation of any product, improper handling or use of any replacement part, or from external electrical or mechanical effects, overvoltage or lightning. Any such improper operation, use or handling shall automatically invalidate the warranty for the product concerned.

In the event a problem arises with your device, or if you need assistance in diagnosing a problem with your device, please contact us at one of the following numbers to arrange to have your device repaired:



+49 (0)221 49708-0



+49 (0)221 49708-178

KOBOLD USA
Tel.: 412-788-2830
Fax: 412-788-4980

2.5 Returning your flowmeter for servicing or calibration

Before sending your flowmeter back to us, for servicing or calibration, make sure it is completely clean. Any residues of substances that could be hazardous to the environment or human health are to be removed from all crevices, recesses, gaskets, and cavities of the housing before the device is shipped.



Warning

The operator is liable for any loss or damage of any kind, including personal injury, decontamination measures, removal operations and the like that are attributable to inadequate cleaning of the device.

Any device sent in for servicing is to be accompanied by a declaration of Decontamination, a template of which is provided in section 8.3.1.

When returned, the device is to be accompanied by a document describing the problems encountered. Please include in this document the name of a contact person whom our technical service department can contact to enable us to repair your device as expeditiously as possible and minimize the repair costs.

2.6 Replacement of the transmitter electronics

Before replacing the transmitter electronics, read the safety instructions in Section 2.4, "Installation and servicing" on page 9.

The data memory chip (DAB) with the calibrating data of the sensor is an integral component of the control unit (display BE4). Removal and installation of the control unit is described in chapter 4.6, "DSB data memory module" on page 25.

Should an exchange of the transmitter electronics become necessary, it is essential that the whole electronic stack is replaced. This comprises of all circuit boards in the electronic compartment and in the terminal compartment. The overall accuracy of the measurement up to the analogous outputs can only be guaranteed when all circuit boards are replaced. Only the control unit with the integrated memory for the calibrating data of the sensor shall remain with the device.



Caution

The complete stack is to be replaced with all of its printed circuit boards (with the exception for the display unit containing the memory module). This is particularly important for the explosion-proof transmitter. The specified precision of the electronics is only guaranteed if the complete stack is replaced.

2.7 Maintenance

2.7.1 Transmitter

The transmitter is maintenance-free.

We recommend cleaning the viewing-glass of the transmitter at regular intervals; check the enclosure for corrosion damages and the solid seat of the cable glands.

**Warning!**

In the event an enclosure lid O-ring gasket is damaged, humidity may enter the enclosure and cause damage to the internal electronic circuits.

Indications of such are:

- Visible discolouration's or condensation on the viewing-glass of the transmitter,
- corrosion damages to the enclosure,

2.7.2 Coriolis mass flow sensor

The sensor is largely maintenance-free. When handled correctly its functionality will only be impaired by corrosion or deposits inside of the measuring tubes. Therefore, both should be implicitly avoided. Remove deposits in the tubes and in or around the splitter on a regularly basis by means of a suitably washing method. Failure to do so may result in a loss of measurement precision.

**Warning!**

In the event of a tube rupture, e.g. due to corrosion or damage, medium will leak into and fill the enclosures body, which can lead to subsequent damage to the external housing, particularly at high process pressures!

3. The TMU-W sensor

3.1 Application domain of the TMU-W sensor

The TMU-W sensor is intended solely for the direct and continuous mass flow measurement of liquids and gases under high pressure, irrespective of their conductivity, density, temperature, pressure, or viscosity. The sensor can be utilised for the direct and continuous mass flow measurement of chemical fluids, suspensions, molasses, paint, varnish, lacquer, pastes and similar materials.

3.2 Mode of operation

3.2.1 Measuring principle

The mass flowmeter is based on the Coriolis principle whereby in a rotating system a force (known as the Coriolis force) is exerted on a mass at a rotation point that is moving towards or away from this point.

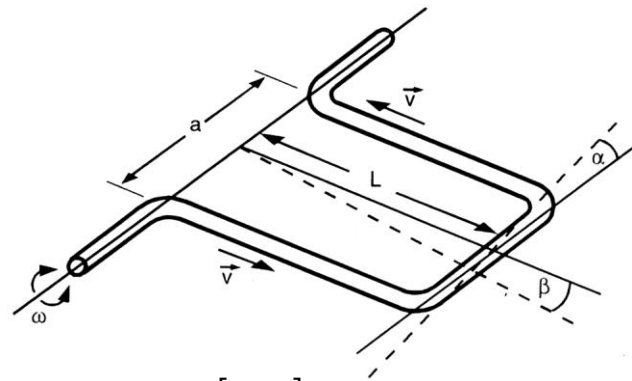

$$F_C = 2 \cdot m \cdot [\omega \times v]$$

3.2.2 System configuration

The flowmeter consists of a sensor mounted in to a piping system and a remote installed transmitter (see Section 4.1, "Application domain of the UMC4" on page 22), connected to the sensor via a special cable (e.g. on a wall or to a pipe).

The transmitter oscillates the flow tubes of the sensor by means of an excitation coil and captures, via pick-up coils, the measuring signal which is proportional to the mass flow. After temperature compensation, the measuring signal is converted into an analogue output signal that is consistent with the measuring range setting.

3.2.3 Acquisition

Measured variables: Mass flow,
 Temperature.

3.3 Performance characteristics of the TMU-W sensor

3.3.1 Reference conditions

- Established flow profile
- Inlet section has to correspond to mounting length
- Control valves always positioned downstream
- Measurement is to be performed with a liquid containing no gas bubbles
- Flow tubes are to be kept clean at all times
- Process temperature is to be regulated as specified in Section 3.4.6, "Process conditions" on page 19
- Process pressure is to be regulated as specified in Section 3.4.8, "Process pressure range" on page 19
- Ambient temperature is to range from + 10 °C to + 30 °C (50 °F to 86 °F)
- Warm-up period: 15 minutes
- Standard calibration is to be performed at 20 %, 50 % and 100 % (two times each)
- High-frequency interference is to be regulated according to the EMC standards stated in section 9, "Declaration of Conformity" on page 115

3.3.2 TMU-W flow ranges

Model	Mass-flow		
	min. Measuring range	max. Measuring range	Zero point stability (of range)
	kg/min [lbs/min]	kg/min [lbs/min]	kg/min [lbs/min]
TMU-W004	0.13 [0.3]	4 [8.8]	0.0004 [0.0009]
TMU-W006	0.5 [1.1]	16 [35.3]	0.0016 [0.0035]
TMU-W012	2.5 [5.5]	25 [55.1]	0.0025 [0.0055]

Table 1: TMU-W flow ranges

Reference conditions: in conformity with IEC 770:

Temperature: 20 °C, relative humidity: 65 %, air pressure: 101.3 kPa

Fluid: water

3.3.3 Density measurement

Due to its constructive properties, a density calibration for the TMU-W family of sensors is not foreseen, thus also disabling the determination of volume flow.

3.3.4 Accuracy

Mass flow	Fluids
TMU-W004 and TMU-W006	± 0.1 % of actual flow \pm zero point stability ⁽¹⁾
TMU-W012	± 0.15 % of actual flow \pm zero point stability ⁽¹⁾
Repeatability error	± 0.05 % of actual flow (sensor with transmitter) $\pm \frac{1}{2}$ zero point stability ⁽¹⁾
Mass flow	Gases
TMU-W004, TMU-W006 and TMU-W012	± 0.5 % of actual flow \pm zero point stability ⁽¹⁾
Repeatability error	± 0.25 % of actual flow (sensor with transmitter) $\pm \frac{1}{2}$ zero point stability ⁽¹⁾
Additional measured values	
Volume flow	Not available
Temperature	± 0.5 °C
Hysteresis	n/a
Settling time	1 to 15 seconds
Startup drift	15 minutes
Long-term drift	± 0.02 % of upper-range value per year
Influence of ambient temperature	± 0.005 % per K
Influence of fluid temperature	Compensated
Influence of fluid pressure	For fluids: too small to be relevant

⁽¹⁾ Refer to section 3.3.2, "TMU-W flow ranges" for detailed information on flow ranges

Table 2: Flow-Rate Accuracy

3.3.5 Pressure loss in Hydrogen dispensers

The pressure loss of gases with constant mass flow is highly dependent on the operating pressure in the mass meter and the resulting flow rate. The TMU-W is designed that its pressure lost will not exceed 30 bar during a standardized refuelling operation with hydrogen and an empty vehicle tank, as defined in the SAEJ2601. With an almost full vehicle tank, the pressure loss shall be much less than 20 bar.

3.3.6 Environmental Conditions

Ambient temperature

- 40 °C to + 60 °C (-40 °F to 140 °F)

Storage temperature

- 40 °C to + 80 °C (-40 °F to 176 °F)

Climatic category

In conformity with IEC 654-1. Unsheltered class D locations with direct open-air climate.

Ingress protection

Sensor: IP 67 (NEMA 6), **Transmitter:** IP68 / 1 m for 24 hours (NEMA 6P) acc. to DIN EN 60529 with mounted and sufficiently tightened approved cable glands.

3.4 Operating conditions

3.4.1 Installation

The sensor is to be protected, wherever possible, against valves, manifolds and similar fittings that generate turbulence. The sensor is to be installed in accordance with the following instructions.

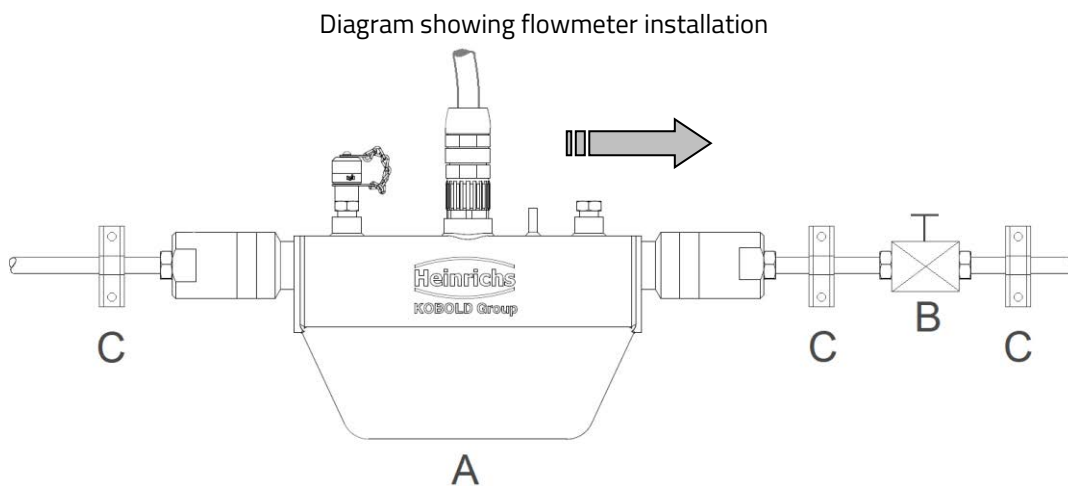

Flowmeter installation: A = sensor, B = valve, C = pipe clamps and supports



The sensor is not to be used to support a pipe or other pipe components.

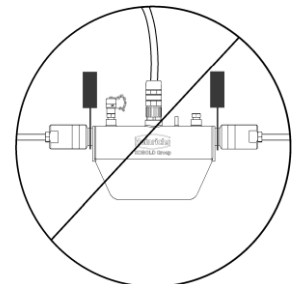

Do not install the sensor in suspended pipes.

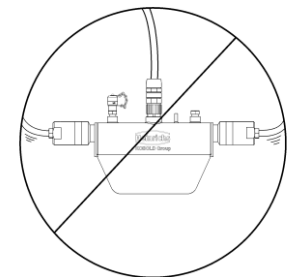

Do not adjust the position of a pipe by pulling or grasping the sensor.

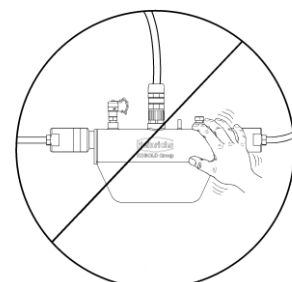

3.4.2 Installation Orientation

Without compromising its accuracy, the TMU-W can be installed and operated in various orientations. The following representations show the most common installation positions and provide tips on how the operator can prevent installation-related influences on the measurement.

Standard installation position

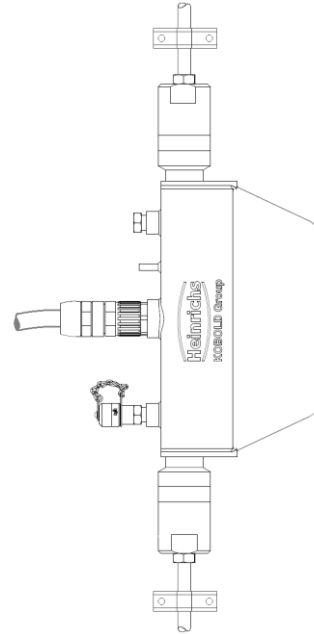

Installation position A

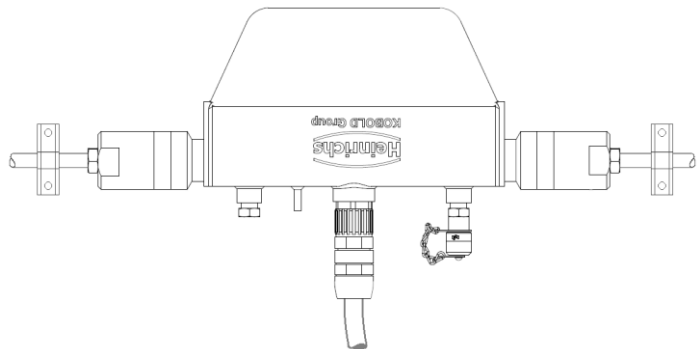

Installation position B

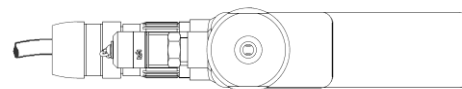

Installation position C

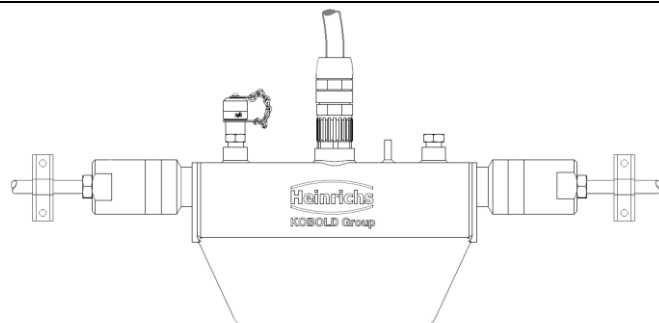

Type of medium	Position	Assessment
Pure liquids	Standard installation position	Self-draining flow tubes
	Position A or B	OK
	Position C	Liquid residue remains in pipe
Liquids containing homogeneously dispersed gas	Standard installation position	Self-draining flow tubes, gas bubbles do not accumulate in flowmeter
	Position A	Not recommended owing to gas bubble accumulation in flowmeter
	Position B	Gas bubbles may accumulate in the presence of low flow velocities
	Position C	No gas bubble accumulation in flowmeter, liquid residues may remain in device after discharge
Liquids containing substances that could form deposits	Standard installation position	Self-draining flow tubes, no deposit formation
	Position A	OK
	Position B	Substances in the liquid could form deposits at low flow velocities
	Position C	Not recommended owing to presence in flowmeter of substances that could form deposits
Liquids containing homogeneously dispersed gas, which may contain substances that could form deposits	Standard installation position	Self-draining flow tubes, no accumulation of gases or substances that could form deposits
	Position A	Not recommended owing to gas bubble accumulation in flowmeter
	Position B	Gas bubbles or substances that could form deposits at low flow velocities
	Position C	Not recommended owing to presence in flowmeter of substances that could form deposits
Gases that do not form condensate	Standard installation position, Position A, B or C	Any of these installations positions can be used
Gas, condensate-forming gas/liquid, moisture	Standard installation position	Flow direction should be from top to bottom so that any condensate that forms can flow out efficiently
	Position A	OK
	Position B	Condensate might form in flowmeter
	Position C	Not recommended owing to condensate accumulation in flowmeter

Table 3: Sensor Installation Positions

3.4.3 Pressure surges

Pressure surges in a pipe could be provoked by a sudden decrease in flow caused by rapid closing of a valve or similar factors. This change in pressure can lead to under-pressure downstream from a valve that has been closed rapidly, and to outgassing. If the valve is mounted directly on the inlet section of the flowmeter, a gas bubble can form in the flow tube that can cause a measuring signal disturbance that would shift the zero point of the output signal. In extreme cases, a pressure surge could cause mechanical damage to the sensors and/or flow tube.

Whenever possible, quick-closing valves should be mounted downstream from the sensor. If this is not feasible, such valves are to be mounted a minimum of 10 x DIA (Φ) from the nearest sensor. Alternatively, valve closing speed can be reduced.

3.4.4 Using the device with hazardous fluids

The sealing technology used in the TMU-W mass flowmeters connector plug renders the device unsuitable for use with hazardous fluids. Only sensors that meet the standards for safety instruments are suitable for use with hazardous fluids.

In the case of welded components, a coloured liquid penetration test can be performed on the welds, or the first seam of the weld can be x-rayed.

3.4.5 Vibration stability

The sensors are insensitive to vibration. Vibration stability has been validated in accordance with DIN IEC 68-2-6, for up to 1 g at 10 to 150 Hz.

If pipe vibration is greater than 1 g in the 5-2000 Hz range, additional supports shall be mounted such as depicted in the following images. Such supports will prevent vibration from affecting the device's mechanical configuration and/or measurement readings.

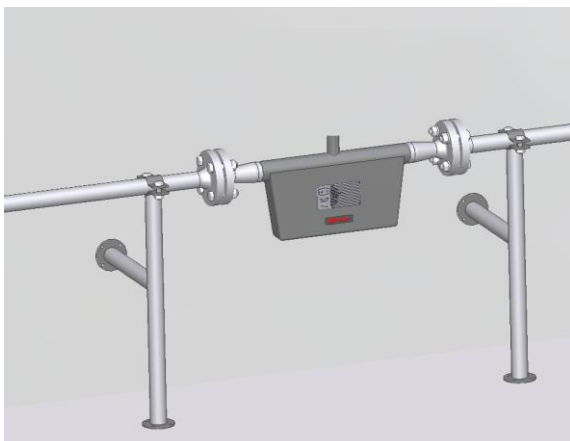

Image 1: Wall mounted supports



Image 2: Floor-mounted supports

3.4.6 Process conditions

Process temperature

– 40 °C to + 100 °C (–40 °F to 212 °F); rating plate specifications apply

Physical state

Liquid product (maximum density 2 kg/l)

Gaseous product (minimum density 0.002 kg/l in operating state)

Viscosity

0.3 up to 2,000 mPas (0.3 to 2,000 cP)

3.4.7 Gas content

The use of products containing gases is not permitted for custody transfer operations. In other applications, the presence of gas will increase false readings. For the readings of products containing gas to be valid, small gas bubbles must be homogeneously distributed in the fluid.

Large gas bubbles will automatically provoke extremely false readings and will shift the zero point. Thus, the extent to which readings are false is determined by the process conditions. A rule of thumb in this regard is as follows: A 1 % gas component will increase false readings by 1 %. The gas component is not to exceed 5 %.

3.4.8 Process pressure range

The applicable pressure range is dependent on the sensor and the selected process connections. It is essential that the correct process connections for the intended process pressure is selected during the ordering process.

TMU-W004 up to 1000 bar

TMU-W006 up to 500 bar

TMU-W012 up to 1000 bar

3.4.9 Outlet pressure

Outlet pressure must be greater than the vapour pressure p_s of the measured product.

3.4.10 Connection to the transmitter

The sensors of the TMU-W family are only available as remote mount versions. The connection to the sensor is achieved via a special ten-cored cable by means of a detachable screw-on connector.

During installation, regulations and applicable legal standards are to be adhered to.

The maximum cable length is 200 m (approx. 650 ft). See Section 5.1.3 on page 36 for information regarding the connection and cable specifications.

3.5 Construction details

3.5.1 Installation lengths and weight

Dimensions and weight:

Sensor length: flange to flange

Model	Process connection	Sensor length		Sensor weight	
		mm	[inch]	kg	[lbs]
TMU-W004	6MF 9/16-18 UNF	347	[13.66]	2.8	[6.2]
	9/16 F562C				
	Hofer 7/8"				
	½ NPT(F),				
TMU-W006	6MF 9/16-18 UNF	400	[15.75]	3.8	[8.4]
	9/16 F562C				
	Hofer 7/8"				
	½ NPT(F),				
TMU-W012	6MF 9/16-18 UNF	415	[16.34]	5.2	[11.5]
	12MF 3/4-16 UNF				
	9/16 F562C				
	Hofer 7/8"				
	½ NPT(F),				

Table 4: Dimensions and Weights

For further dimensions of the sensors, refer to the dimensions drawings in the following sections

3.5.2 Dimension drawing for the type TMU-W004

Remote mount configuration with IP67 Connector suitable for process temperatures up to 100 °C (212 °F):

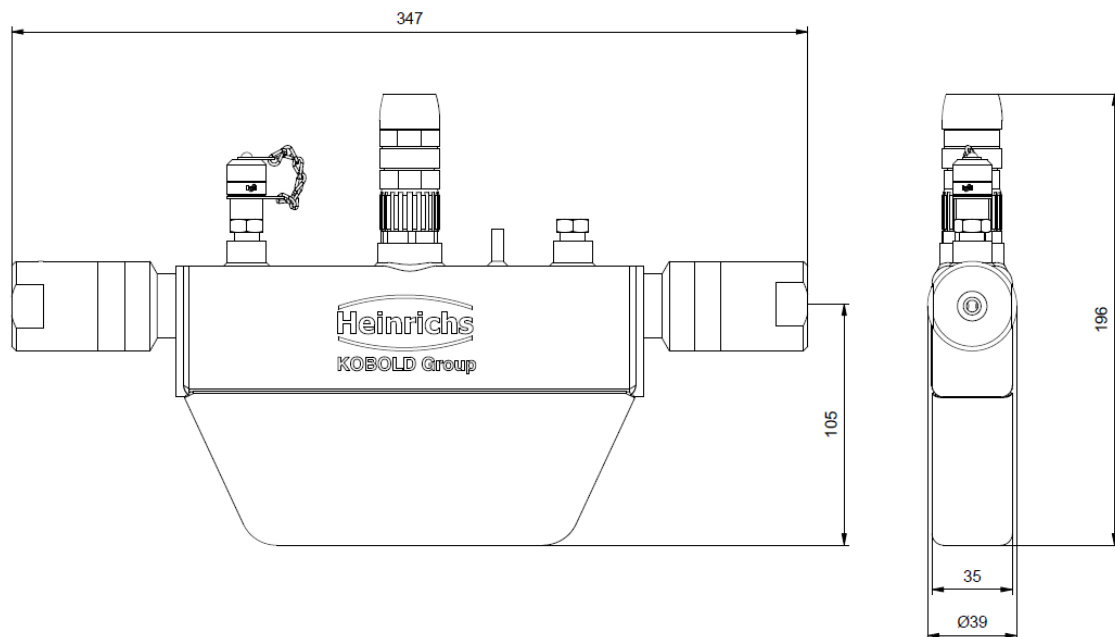

For further dimensions and weight, see Section 3.5.1, "Installation lengths and weight" on page 20.

3.5.3 Dimension drawing for the type TMU-W006

Remote mount configuration with IP67 Connector suitable for process temperatures up to 100 °C (212 °F):

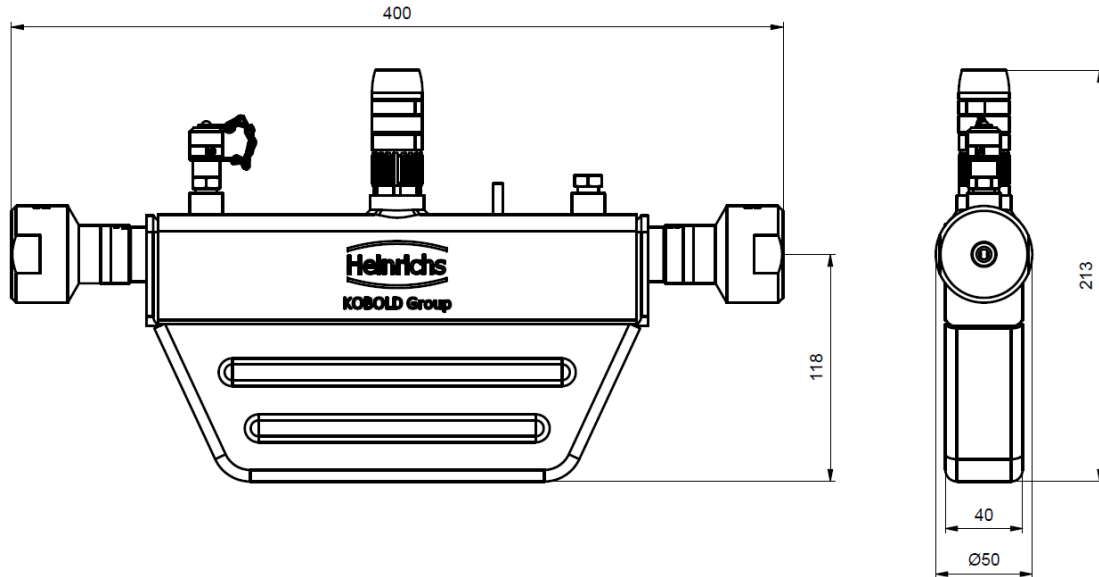

For further dimensions and weight, see Section 3.5.1, "Installation lengths and weight" on page 20.

3.5.4 Dimension drawing for the type TMU-W012

Remote mount configuration with IP67 Connector suitable for process temperatures up to 100 °C (212 °F):

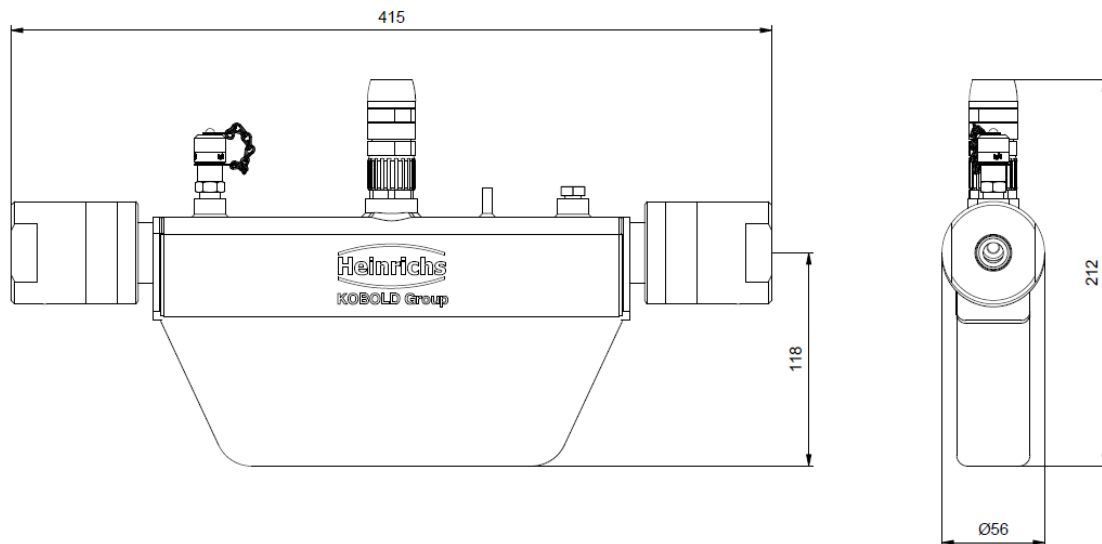

For further dimensions and weight, see Section 3.5.1, "Installation lengths and weight" on page 20.

3.5.5 Materials

Sensor housing:	1.4301 (304L)
Flow tubes:	1.4571 (316Ti)
Splitter:	1.4571 (316Ti)
Flange Connectors:	1.4571 (316Ti)

4. UMC4 transmitter

4.1 Application domain of the UMC4 transmitter

The UMC4 transmitter (hereinafter referred to as UMC4) for use with TM, TME TMR, TMU, TM-SH and HPC Coriolis mass-flow sensors, is a programmable transmitter designed to capture and process measurement data from its associated sensor for displaying on its built-in display or for the transmission of measurement results via various interfaces.

Via its BE4 control unit, the UMC4 can be customised for use to fit a variety of applications. Although basic configuration settings such as transmitter calibration are factory performed, other parameters such as those for measurement data processing, analysis, display and output are user definable.

4.2 Mode of Operation

The Coriolis mass flow meter works on the principle that in a rotating system a force (known as Coriolis force) is exerted on a mass at a rotation point that is moving towards or away from this point. Utilising a suitable sensor construction, this force can be exploited for the direct measurement of the mass flow. The UMC4 transmitter measures and evaluates signals received from sensors positioned on the flow tubes (see Section 3.2.1, "Measuring principle" on page 12).

4.3 System configuration

Transmitter:

The UMC4 transmitter regulates the excitation of the sensor vibration system and processes the sensor signals. The standard model is equipped with two analogue, passive 4 to 20 mA outputs, an impulse or frequency output and a status output, and is enabled for digital data transfer via the HART® protocol.

Sensor:

Coriolis sensors measure mass-flow, density and temperature of fluids or gases. They can be used to perform measurements with any liquid or gaseous product providing that the sensor material is suitable for the product to be measured.

4.4 UMC4 performance characteristics

4.4.1 Reference conditions

In conformity with IEC 770

Temperature: 20 °C (68 °F), relative humidity: 65 %, air pressure: 101.3 kPa (14.7 psi)

4.4.2 Measured error

For measurement errors and zero point stability refer to the sensor data sheet in section 3.3.2, "TMU-W flow ranges" on page 13.

4.4.3 Repeatability error

± 0.05 % of the actual value (Sensor with transmitter).

For more details refer to the sensor data sheet or section 3.3.2, "TMU-W flow ranges" on page 13.

4.4.4 Influence of ambient temperature

Max. ± 0.05 % per 10 °C

4.5 Operating conditions

4.5.1 Installation conditions and cable glands

The integral mount version of the UMC4 transmitter shall be installed in accordance with the sensor installation requirements stated in section 3.

When selecting the position of installation, especially for the remote-mounted UMC4, ensure a vibration-free mounting.



Warning:

Cable glands are not contained in the basic scope of supply. The operator is responsible for ensuring that cable glands or plugs according to the enclosures type of EX-protection and the provided threads are used. The enclosures thread type is stated on the transmitters rating plate.



Caution:

Where applicable, metalized cable gland must be used for the sensor / transmitter cable to ensure a sufficient conductive connection for the cable shield.
(See section 5.1.3, "Sensor connection" on page 36)

4.5.2 NPT cable glands

The transmitter housing is designed for use with M20x1.5 threaded cable glands. For NPT threaded cable glands the manufacturer adds certified NPT adapters. These NPT adapters are mechanically fixed to the thread of the transmitter housing.



Warning:

NPT adapters mounted by the manufacturer may never be removed by the customer! In the event of a removal of these adapters, the protection class Ex-d can no longer be guaranteed.

4.5.3 Environmental conditions

Ambient temperature

– 20 °C to + 60 °C (–4 °F to 140 °F), below 0 °C (32 °F) readability of the LC display may diminish.

Storage temperature

–25 °C to + 60 °C (–13 °F to 140 °F)

Climatic category

In conformity with IEC 654-1. Unsheltered class D locations with direct open-air climate.

Vibration immunity

The UMC4 is insensitive to moderate vibration; vibration stability has been validated in accordance with DIN IEC 68-2-6, for up to 1 g at 10 to 150 Hz.

Ingress protection

Standard UMC4 housing, IP 68 / 1 m for 24 hours (NEMA 6P)

Explosion-proof single compartment electronics enclosure (Ex-db)

Terminals: The process terminals are situated at the back-end of the single compartment Ex-d enclosure.



Caution:

Ingress protection IP 68 can only be guaranteed if suitable and sufficiently tightened cable glands or conduits are used. If the cable glands are not tightened sufficiently, water may leak into the terminal compartment of the enclosure and cause damage to the electronics.



Caution:

Particular care must be taken if the enclosures viewing window becomes fogged or discoloured, which may be an indication of moisture, water or product seeping through the wire sheath into the transmitter's housing.



Caution:

Electromagnetic compatibility can only be guaranteed if the lids of the enclosure are securely tightened. Leaving the enclosure open may lead to electromagnetic disturbances.



Warning

In Ex hazardous areas, only sensors and transmitters marked as such on their rating plates may be used!

4.5.4 Process conditions

For detailed information on the process conditions and specifications, please refer to section 3.3, "Performance characteristics of the TMU-W sensor".

When compact mounted, the process conditions can influence the operation of the transmitter if the manufactures installation and operational conditions are not abided to.

Remote mounted transmitters are not affected by the prevailing process conditions of the sensor

**Note:**

Compact-mounted transmitters are not available for all versions of sensors.

4.6 DSB data memory module

The memory device is integrated on the PCB of the control unit where all sensor data such as sensor constants, model numbers, serial numbers, and so on are stored. Consequently, the memory module is linked to the sensor. If the transmitter's electronics are exchanged for any reason, the control unit BE4 must be removed from the old and installed onto the new electronic stack.

**Warning:**

When replacing the transmitter electronics, ensure that the applicable standards and regulations pertaining to electrical devices, device installation and process technology are abided to. The highly integrated electronic components of the UMC4 may be damaged when exposed to ESD hazards. Only when installed in the transmitters enclosure are the electronics compliant to EMC standards.

Exchanging the Control Unit

To exchange the BE4 control unit abide to the following instructions referring to the image on the following page.

After loosening the 4 screws situated below the foil, the control unit with the display can be detached together with the foil. For this purpose, the foil itself does not need to be removed.

When transferring the BE4 PCB to a new electronic stack, care should be taken to ensure the correct seating of the 10 poled connector. An incorrectly plugged connector will lead to malfunction and may also damage the electronics.

Removal and exchange of the BE4 Control unit:

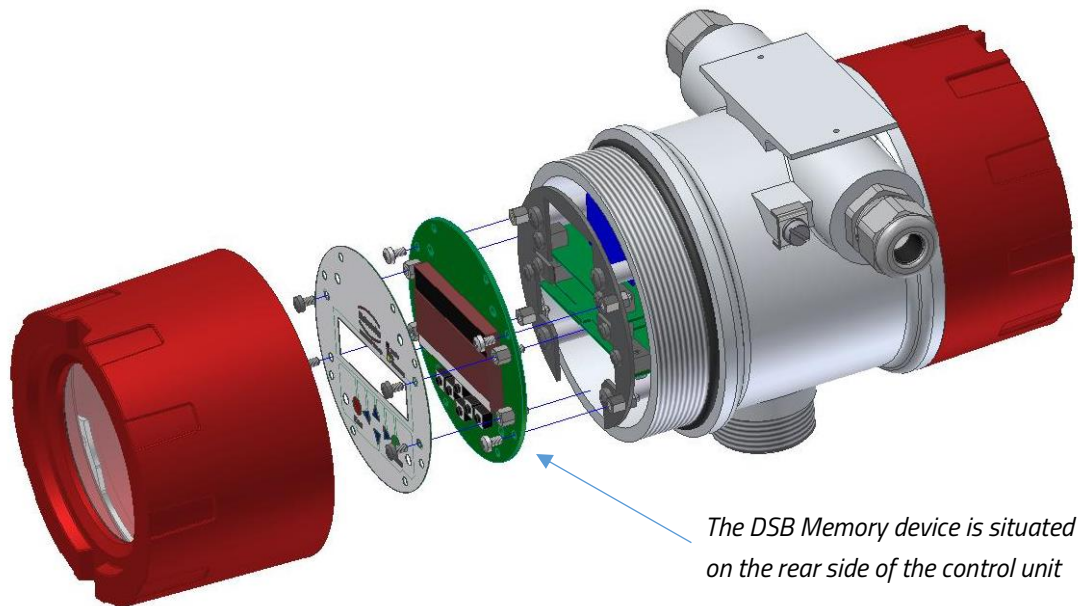

When the flow meter is powered up, the device continues using the values stored in the memory device. Thus, the DSB memory device provides maximum safety and comfort when device components are replaced.

Due to the device specific parameters saved in the memory device, the control units are not arbitrarily interchangeable between identically constructed transmitters. Replace circuit boards must be ordered from Heinrichs using the transmitter's serial number specification. The calibration data of the sensor are programmed into the delivered BE4 control panel directly by the manufacture

4.7 Input measured variables

4.7.1 Measured Values

The UMC4 measures via the connected sensor the following variables:

- mass flow rate,
- temperature,
- density

A fourth variable, the volume flow, is derived from the measured variables; mass flow rate and density.



Note:

Density and volume variables are not available for all sensor types.

4.7.2 Measuring range

The measuring range, which varies according to the used sensor (TM, TME, TMR, TMU or HPC), can be found in the relevant data sheet and in sections 3.3.2, "TMU-W flow ranges" and 3.3.3, "Density measurement" on page 13.

The specified measuring range of the delivered sensor is also printed on the devices rating plate.

4.8 Outputs

4.8.1 Output circuits

All Signal output circuits of the UMC4 are configured as passive outputs and therefore require an auxiliary power input for operation. They are isolated from the rest of the UMC4 circuitry via optocouplers. Each output circuit is also galvanically isolated from each other as well as to ground.

Analogue outputs:	2x 4 to 20 mA passive current outputs
Current output 1:	Mass flow, volume flow, density, temperature (Output 1 superimposed with HART® protocol)
Current output 2:	Mass flow, volume flow, density, temperature

Refer to section 4.8.2, "Current outputs" on page 28 for connection advice and section 7.2.10, "CURRENT OUTPUTS functional class" on page 82 for programming of the current outputs

Binary outputs:	2x Binary outputs (NPN)
Pulse output:	Pulse duration: default value 50 ms adjustable range is 0.1 to 2000 ms (0.0 = Automatically set) Pulse-pause ratio is 1:1 if the set pulse duration is not exceeded. As a frequency output max. 1 kHz Pulse value: settable in decade increments of selected pulse unit
Status output:	For: forward and reverse flow, MIN flow rate, MAX flow rate, MIN density, MAX density, MIN temperature, MAX temperature, alarm Second pulse output (phase-shifted to Pulse1 by 90°)
Max. Electrical values:	Unom = 30 V Imax = 200 mA

Refer to section 7.2.8, "PULSE OUTPUT functional class" on page 76 and 7.2.9, "STATUS functional class" on page 79 for programming of the binary outputs.



Warning:

For connection to, as well as the maximum electrical output parameters of the transmitter for use in potentially Explosive Atmospheres refer to the relevant type examination certificate or the applicable Ex-supplementary operating manual.



4.8.2 Current outputs

4.8.2.1 Accuracy

Maximal error of the current outputs is $\pm 0.1\%$ of the actual reading + 0.05% full scale flow.

4.8.2.2 Load

Standard version:	≤ 500 ohms
Explosion-proof version:	≤ 500 ohms
HART® minimum load:	250 ohms

The minimal voltage required at the passive current output terminals to ensure correct operation is 10 V.

The maximum voltage of 30 V must never be exceeded.

The maximum load is dependent on the applied terminal voltage and can be calculated using the following equation:

$$R_{\max} = \frac{U - 10V}{23mA} \leq 500\Omega$$

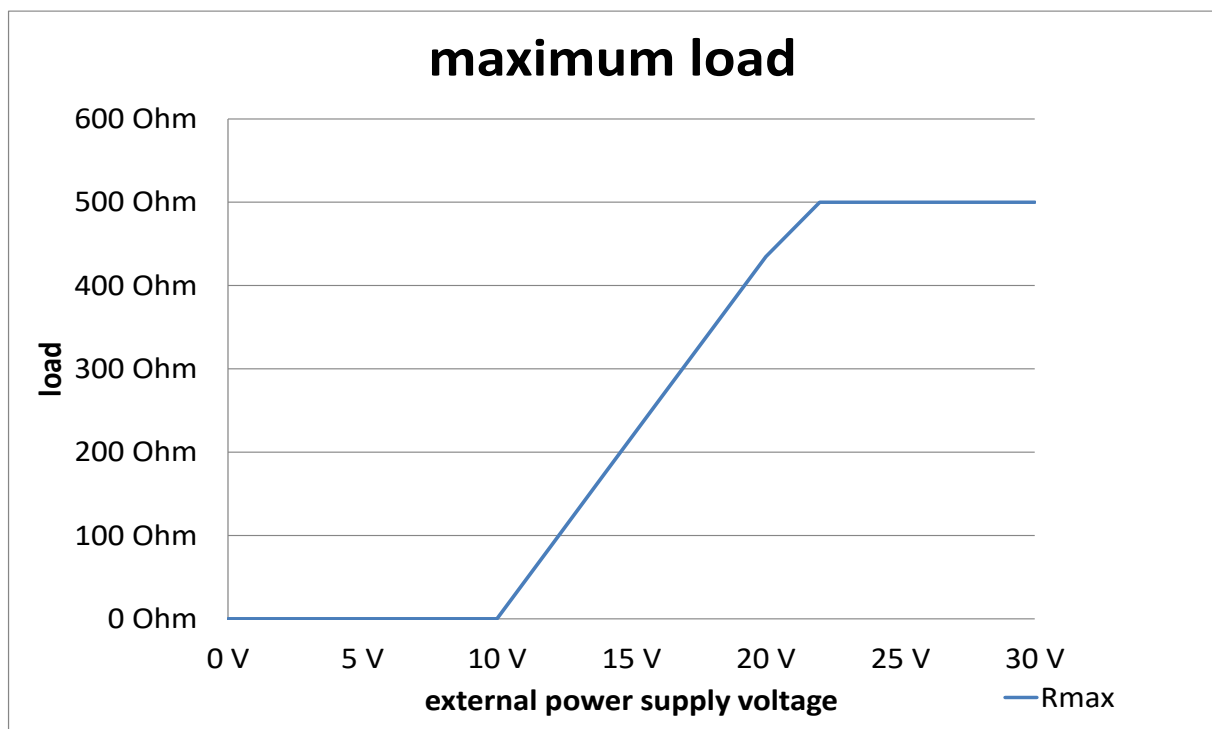

Figure 1: Maximum Loads of the Current Outputs

4.8.2.3 HART®

A number of connection possibilities are available for HART® communication, with the condition that the loop resistance is less than the maximum load specified in Section 4.8.2, "Current outputs" on page 28. The HART® interface is connected via terminal 11 and 12 or 41 and 42 respectively. The minimum load impedance of $250\ \Omega$ must be adhered to.

For information regarding operation of the transmitter using the HART® hand-held terminal, see "Operation of the UMC4 transmitter using the HART® hand-held terminal."

Communication via Siemens PDM®

PDM® is the configuration software of Siemens that is used to operate HART® or Profibus PA compatible devices.

To connect a desktop or laptop computer to the UMC4, a HART® interface is required in addition to communication software such as PDM. The HART® interface, which has two connections, converts the levels of the RS 232 interface or USB interface into an FSK signal (frequency-shift keying).

For further details see section 3.4.10, "Connection to the transmitter" on page 19

4.8.2.4 Damping

The damping of the output signals is programmable from 1 to 60 seconds.

The standard factory setting is 3 seconds.

4.8.2.5 Error indication

An error in, or failure of the meter can be indicated via the current outputs or the status output. The current outputs can be set to a failure signal (alarm) of $I < 3.8 \text{ mA}$ or $I > 22 \text{ mA}$. The status output can be configured as a make or break contact.

4.8.2.6 Low flow cut-off

The low flow cut-off can be set to values between 0 and 20% via the menu. The set value is a percentual value of the upper-range setting. If the measured value is lower than the set cut-off, the flow rate will be set to 0.0 (kg/h). This results in the analogue output being set to 0/4 mA, and the pulse output will cease generating pulses.

4.8.3 Binary Outputs

The binary outputs utilise NPN transistors for the transmission of their data. To collect this data (e.g. Pulses), the connection of an external circuitry is necessary. Image 3 depicts an example of such a circuit. For use in EX atmospheres, refer to the EX-supplement manual for additional connection requirements.

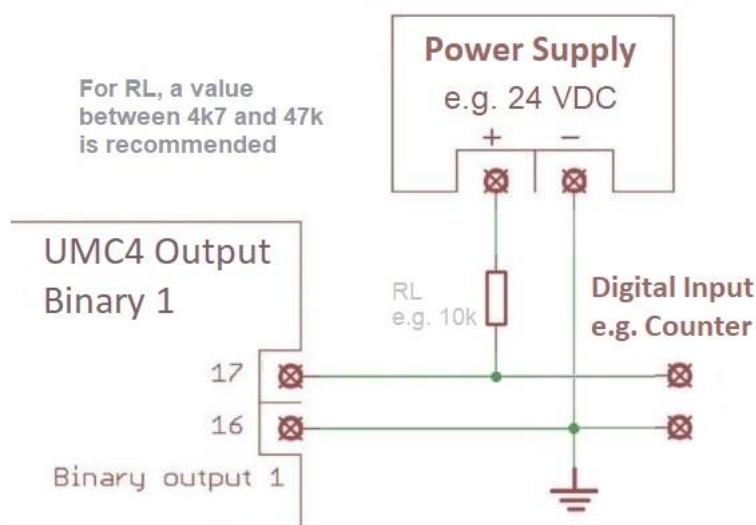

Image 3: Example for wiring a Binary output

4.9 Construction details UMC4

The UMC4 with the standard field enclosure possesses a variety of mounting options, making it adaptable to available local circumstances.

4.9.1 Mounting / Dimensions

Horizontal pipe mounting

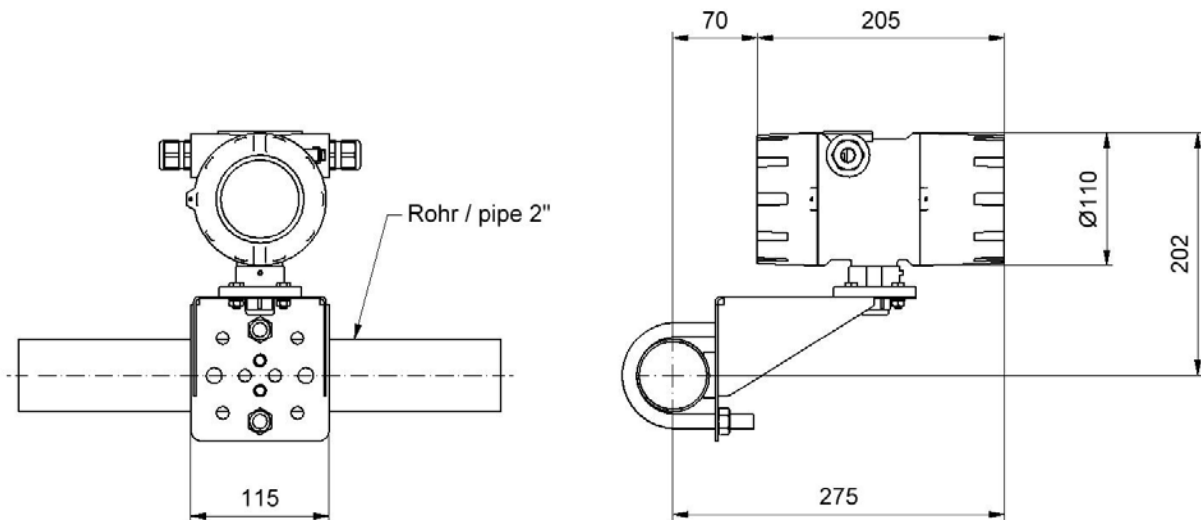

Vertical pipe mounting

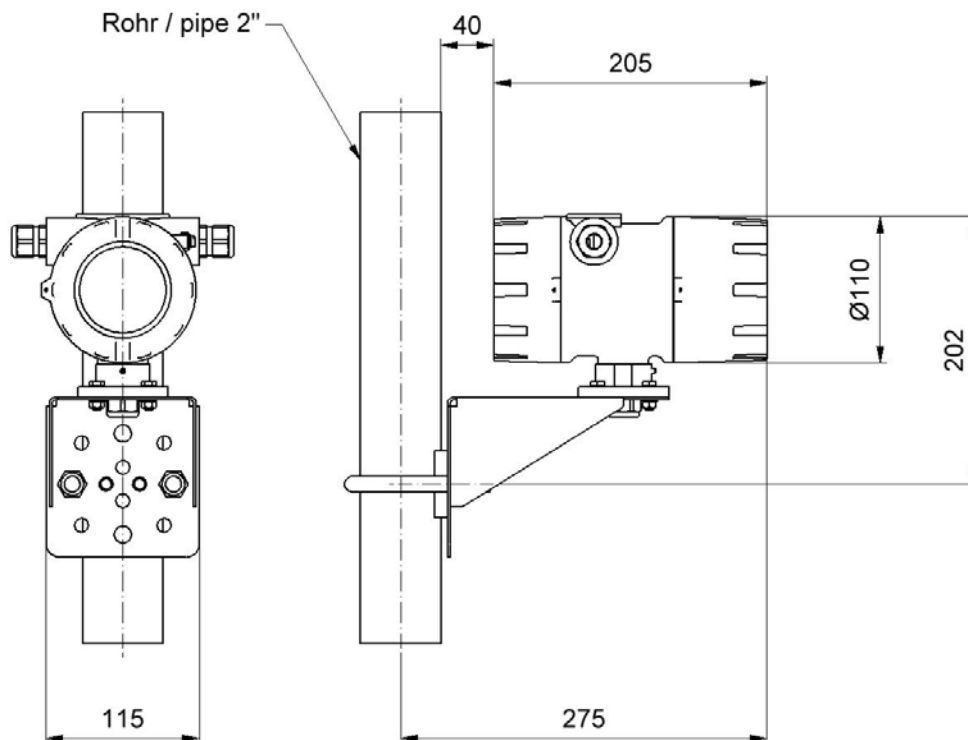

Wall mounting

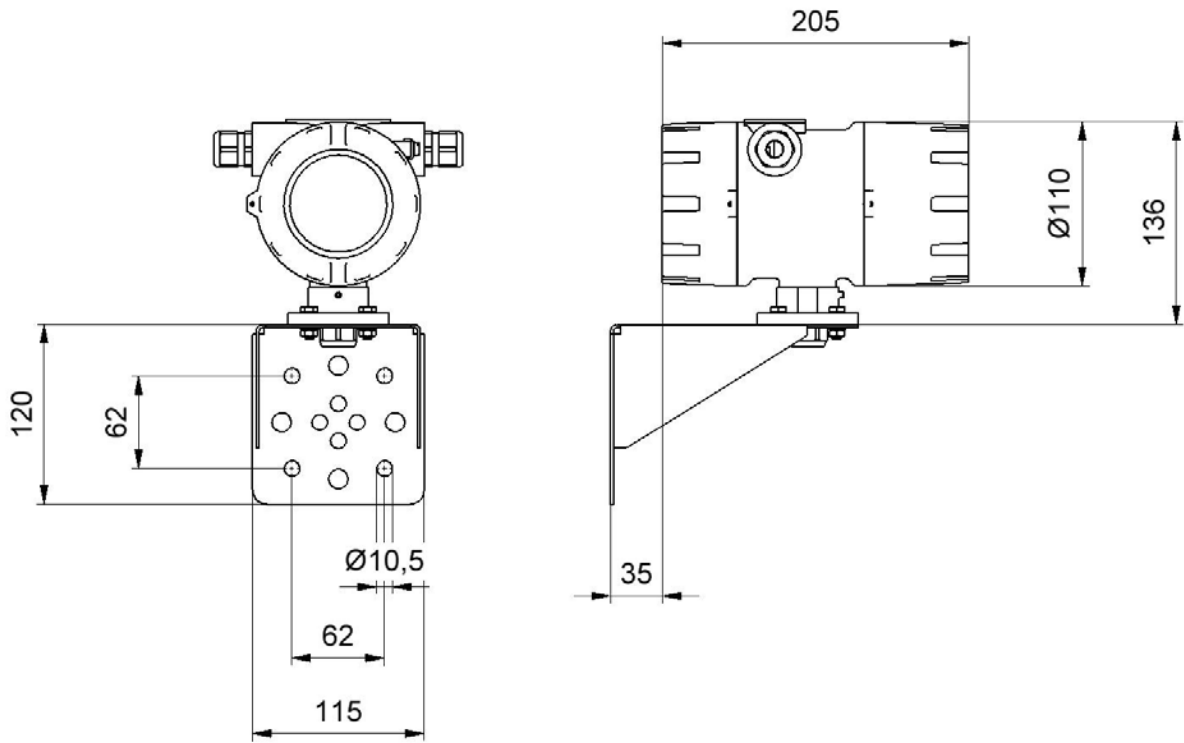

Pipe mounting with a junction box

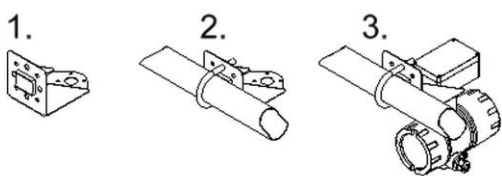
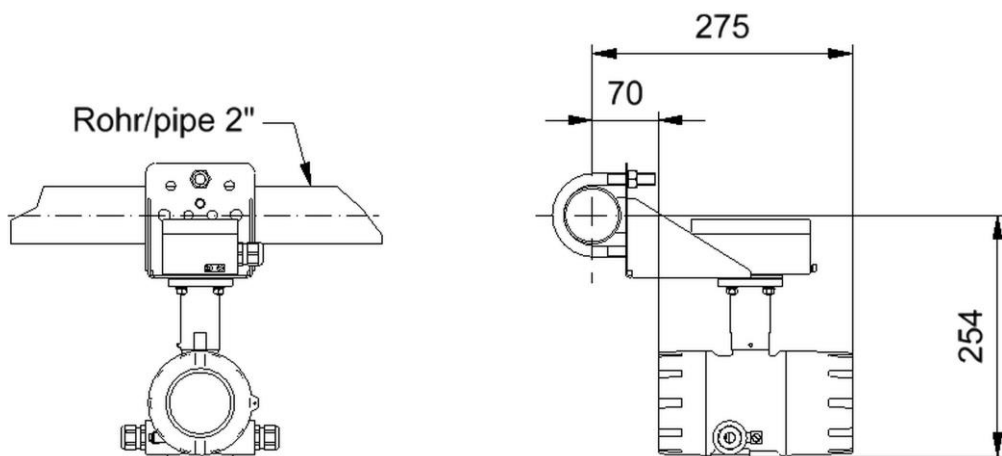

4.9.2 Weight

Approx.: 2.4 kg (5.5 lbs) (separate UMC4 transmitter without mounting system)

4.9.3 Material

Enclosure: Aluminium pressure die-casting, max. 0.5% Mg; yellow chromate.
Chemically resistant paint.

Terminal box: Aluminium pressure die-casting. Chemically resistant paint

Connection neck: 1.4301 stainless steel

Mounting bracket: 2 mm thick sheet stainless steel / (6 mm with ships approval)

4.10 Construction details UMC4-RM

The UMC4-RM is designed as a rack-mount transmitter designated for installation and operation in an area protected against harsh environmental conditions.

4.10.1 Dimensions

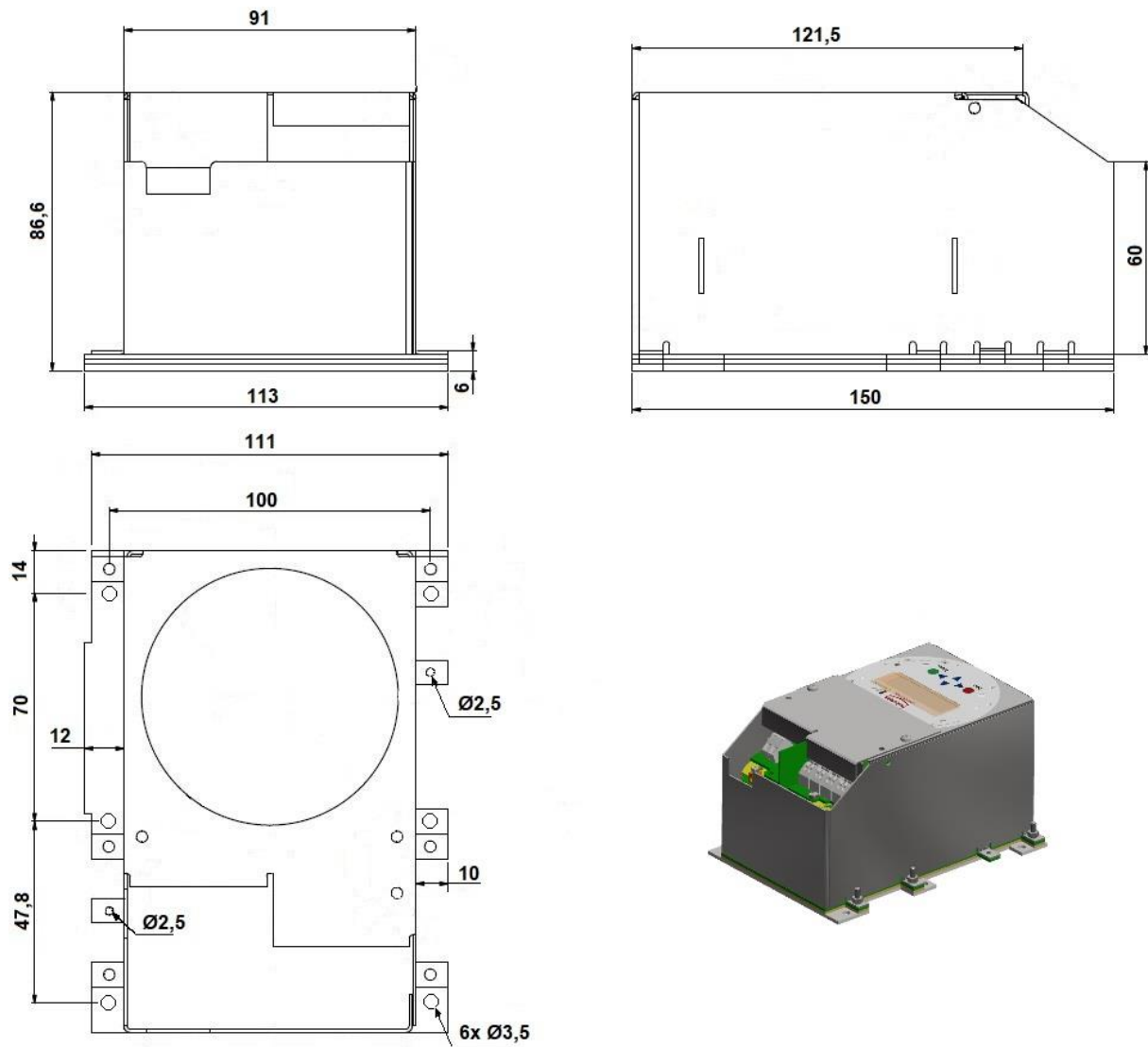

4.10.2 Mounting bore pattern

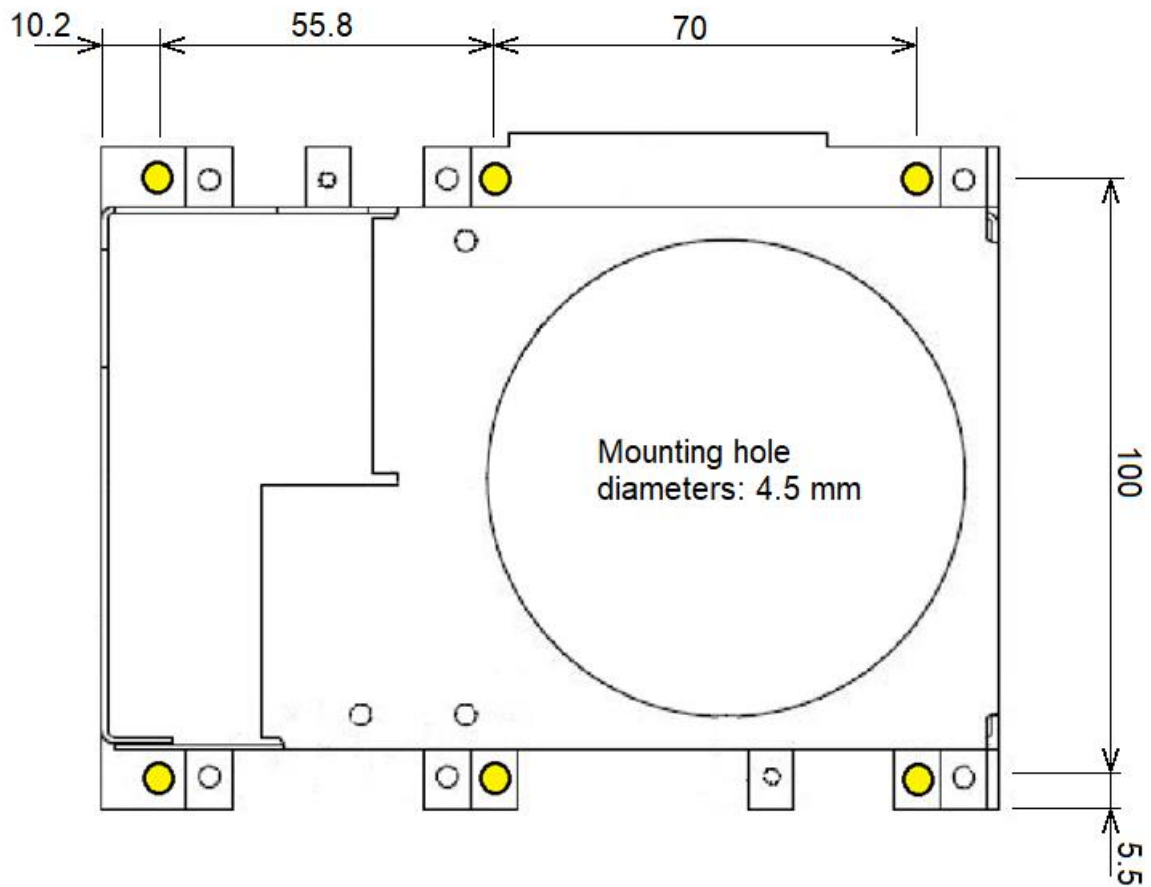

Note: The above depiction is not in scale and is therefore not suitable to be used as a mounting template.

4.10.3 Weight

Approx.: 1.1 kg (2.4 lbs)

4.10.4 Materials

Main electronic hood:	1 mm thick sheet stainless steel
Terminal hood:	1 mm thick sheet stainless steel
Base plate:	2 mm thick aluminium plate
Display Foil:	Polyester (Breakdown Voltage = 16.5 kV)

The aluminium base plate is conductively connected to the ground plane of the electronics and provides an optimal ground plane for the electrical connection to the ground plane of the systems rack.

The enclosure possesses no Ingress protection and must be protected from environmental influences.

5. Electrical Connections UMC4

5.1 Mains connections and their protection classes

Auxiliary power ⁽¹⁾	19 V to 36 V DC (nominal 24 V DC)	
	24 V AC + 5 %, - 20 %	50/60 Hz
	90 V - 265 V AC	50/60 Hz

(1): For custody transfer operations, the transmitter is only available as a 24 VDC version.

Power input	4.5 VA
Main fuse:	5x20 mm IEC 60127-2

Main voltage	rated Current	rated voltage	breaking capacity
19V ... 36V DC	250mAT	250V AC	1500A / 250V AC
24V AC	250mAT	250V AC	1500A / 250V AC
90V ... 265V AC	250mAT	250V AC	1500A / 250V AC

Table 5: Fuse properties

Fuse Type: Little Fuse Series 0215.250 HXP

UMC4 Fuse holder

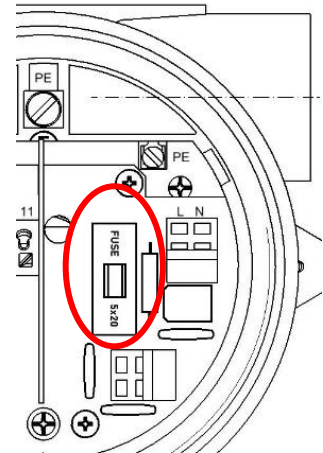

5.1.1 Wiring diagrams

Terminal Designation of the Power connections

Transmitter Type	Pin designation	Ex Type of protection		Standard
		Ex ec	None (Protected by Ex db)	(Non Ex)
UMC4	L, N and PE		x	x
UMC4-RM	L, N and PE	x		x

Table 6: Power Terminals Designation

On DC Voltage devices, L represents the “+” and N the “-” of the supply lines.

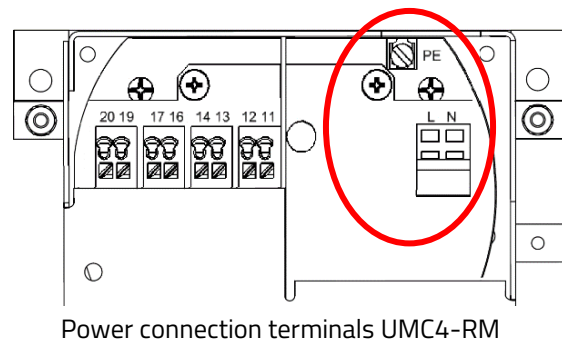
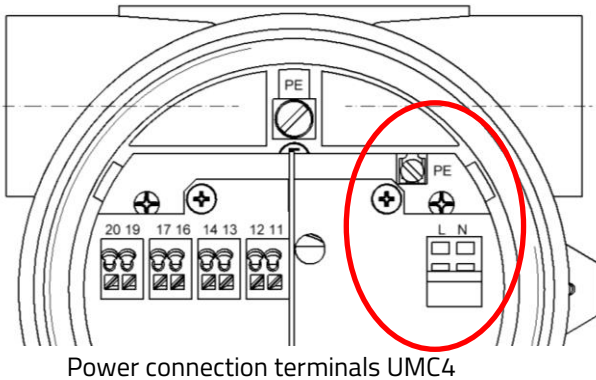

5.1.2 The output terminals

For connection in explosive environments, the output signals of the UMC4 are available in various-protection classes.

The designations of the terminals varies depending on the ordered protection class.

The terminal designation and their protection class can be taken from the following table:

Terminal Designation of the Signal Outputs

Designation	Terminal designation and (Polarity)	Type of protection Ex-device		Standard device (Non-Ex)
		Ex ia	non-Ex ia	
Current 1, 4 to 20mA with HART®	11(-) and 12(+)	x		x
	41(-) and 42(+)		x	
Current 2, 4 to 20mA	13(-) and 14(+)	x		x
	43(-) and 44(+)		x	
Binary output 1 (passive pulse)	16(-) and 17(+)	x		x
	46(-) and 47(+)		x	
Binary output 2 (status or 2nd passive pulse output)	19(-) and 20(+)	x		x
	49(-) and 50(+)		x	

Table 7: Signal Output Terminals Designation

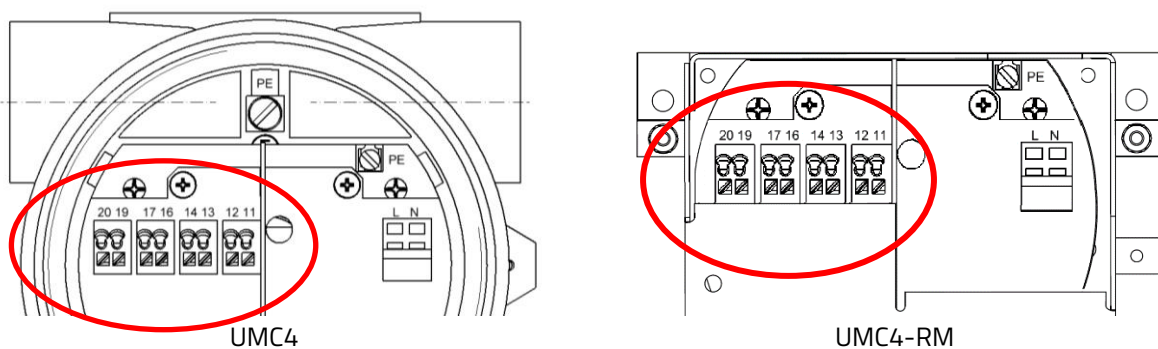

Output Signals shown in Ex-ia type of protection

5.1.3 Sensor connection

Depending on the purchased transmitter variant and its associated sensor type, the connection to the UMC4 can be configured either with a pigtail cable, an IP67 terminal box, or in the case of the UMC4-RM with external terminal blocks.

The pigtail cable version is mounted to the UMC4 during construction, is considered an integral part of the transmitter and may only be dismantled/replaced by trained personal.

Wire designation of the sensor cable

Designation	Terminal / Pin designation	Type of protection	
		Ex ia	Non-Ex (Standard)
Sensor lines			
SENSOR1 +	1	x	x
SENSOR1 -	2	x	x
SENSOR2 +	3	x	x
SENSOR2 -	4	x	x
Tlk-	5	x	x
Temperature sensor -	6	x	x
Temperature sensor +	7	x	x
Tlk+	8	x	x
EXCITER1	9	x	x
EXCITER2	10	x	x
Shield	Shield	x	x

Table 8: Wire designation of the sensor cable

For the connection between the sensor and transmitter, one of the following cables is supplied:

- Non-explosion proof applications SLI2Y(ST)CY 5 x 2 x 0.5 mm² grey (max. 300 m)
- Explosion-proof applications SLI2Y(ST)CY 5 x 2 x 0.5 mm² blue (max. 300 m)
(blue for explosion-proof applications, grey for non-explosion proof applications).

Customer specific cable lengths can be ordered during the ordering process.

Attention: Cables not certified by the manufacturer may impair the accuracy of the measurement as well as EMC compliance.

Suitable alternative cables:

SLI2Y (ST) C11YÖ 5 x 2 x 0.5 mm or
SG [5(2 LiY 0.50)St]FStC11Y

5.1.3.1 Connection via Terminal Box

When both sensor and transmitter are fitted with terminal boxes, the connection cable is prepared at both ends for the connection to the terminals and cable gland of the terminal box.

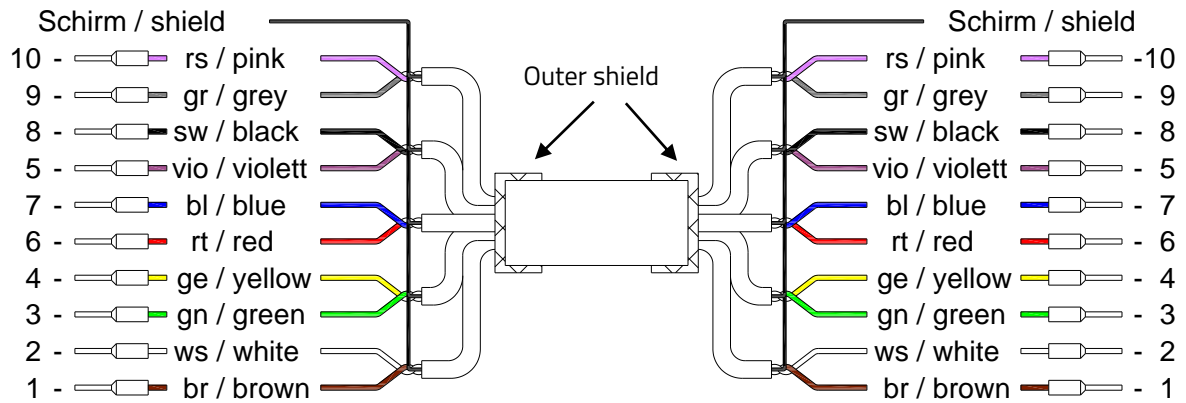

The outer shield is connected to the terminal box cable glands at both ends, The inner shields of the wire-pairs are connected to each other (drilled together) and connected to the "Schirm / Shield" terminal in the terminal box.

5.1.3.2 Connection via Connector Plug

When the associated sensor is fitted with a connector, the connection cable is prepared with a pre-fabricated connector plug at one end, and wires for the connection to the terminals and cable gland of the of the UMC4 terminal box at the other end.

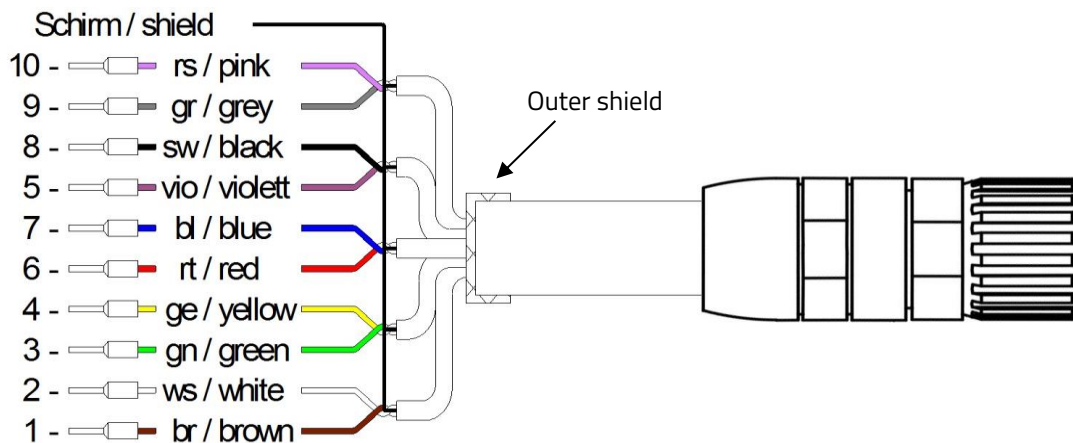

The outer shield is connected to the terminal box cable gland at one end, and the connector's outer-case at the other end. The inner shields of the wire-pairs are connected to each other (drilled together) and connected to the "Schirm / Shield" terminal in the junction box.



Caution:

The colours of the sensor's wires in the terminal box may differ to the colours of the connection cable's wires between terminal box and transmitter! Decisive for the connection is the numbers of the terminal in the terminal box and transmitter.

UMC4 with pigtail connection cable
For connector pin assignment, see the table on page 37

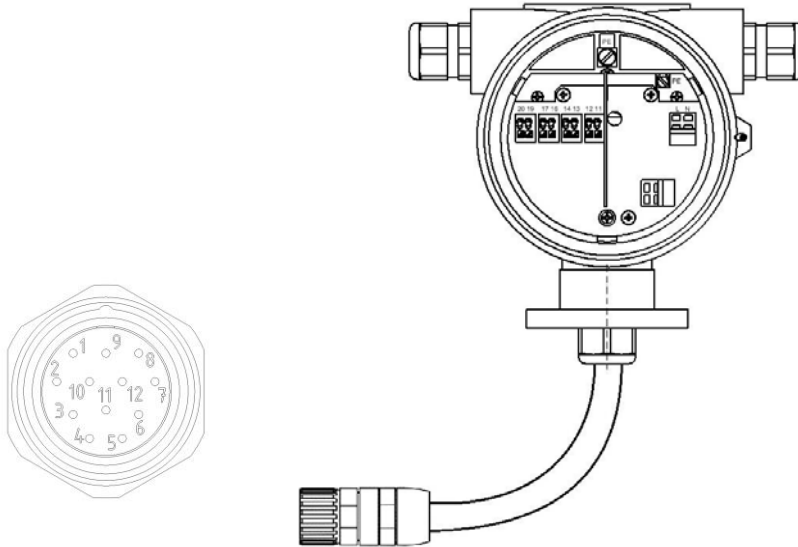

For advice on cable glands: See also 4.5.1, "Installation conditions and cable glands" on page 23.

UMC4 junction box and WAGO terminals
For terminal assignment, see the table on page 37

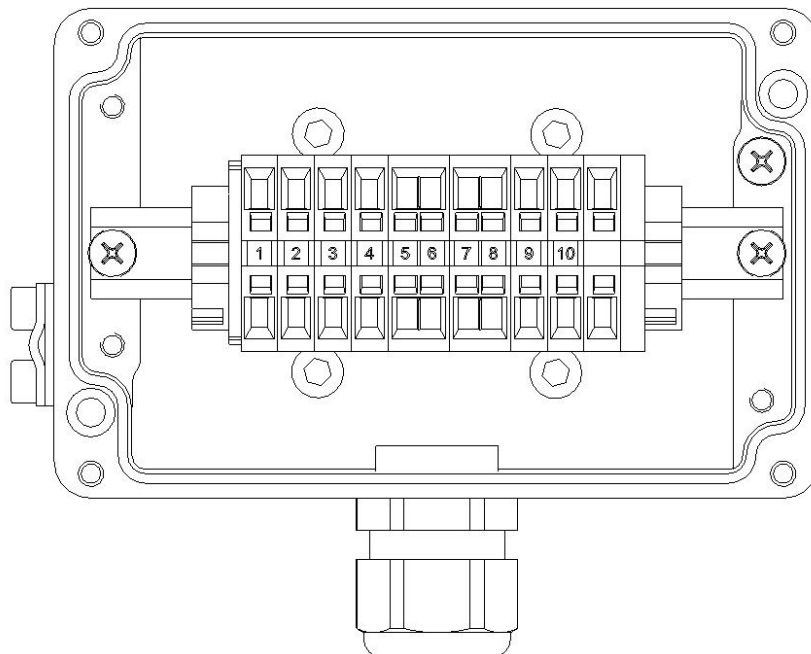

For advice on cable glands: See also 4.5.1, "Installation conditions and cable glands" on page 23.

UMC4-RM (Rack-Mount) and terminal blocks
For terminal assignment, see the table on page 37

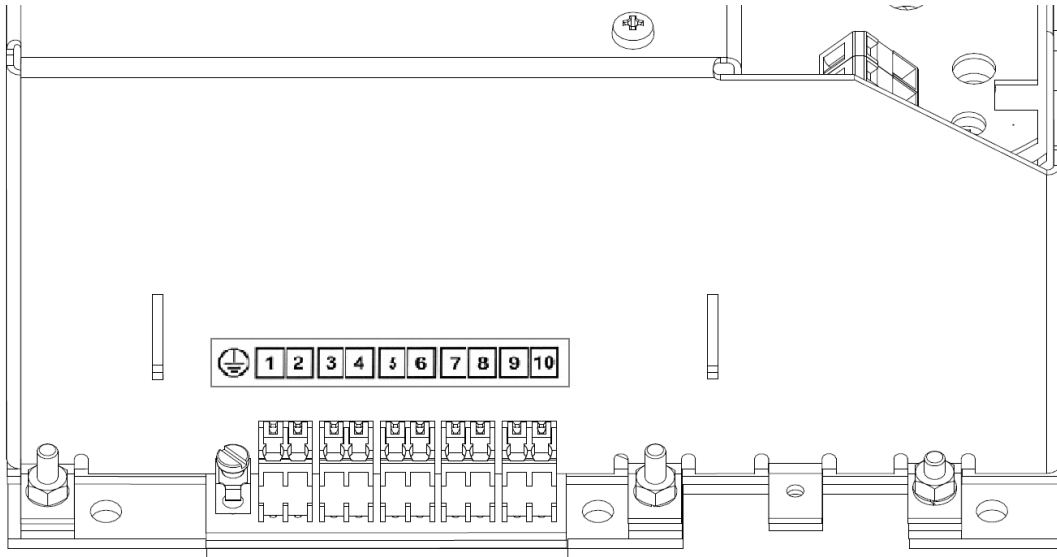

The connected cable requires a strain relief near the terminal blocks

6. Certificates and Approvals

6.1 Conformity to CE Directives

The measuring system complies with the legal requirements of the following directives:

- **2014/30/EU:** Electromagnetic Compatibility Directive
- **2014/34/EU:** ATEX Directive
- **2014/35/EU:** Low Voltage Directive
- **2014/68/EU:** Pressure Equipment Directive

The attachment of the CE mark indicates that the device complies with the aforementioned directives. Refer to section 9 "Declaration of Conformity" on page 115 for detailed information.

6.2 Explosion protection

The transmitters and sensors are separately certified for use in explosive atmospheres. When designated for use in such atmospheres, it is essential that the Ex-supplement manual of the relevant device is obtained to supplement this manual. The Ex-supplement manual contains additional important information regarding installation in potentially explosive atmospheres.

Certificate numbers EX

Certification Type	UMC4	UMC4-RM	TMU-W
ATEX (Europe)	BVS 10 ATEX E110 X	BVS 20 ATEX Exxx X	DMT 01 ATEX E149 X
IECEX (Int.)	IECEX BVS 11.0088X	IECEX BVS 20.xxxxX	IECEX BVS 11.0084X
KCS (S. Korea)	12-KB4BO-0117X		12 KB4BO-0116X

Table 9: Certifications Explosion Protection

Type Approval certificates are available on our website www.heinrichs.eu, or upon request.

6.3 Custody transfer applications

The Combination UMC4/TMU-W004 and UMC4RM/TMU-W004 possess an evaluation certification according to the OIML-CS Scheme for conformance to the following recommendations:

Certificate numbers OIML

Certification Type	UMC4	UMC4-RM	TMU-W004
OIML R139 (Hydrogen)	PENDING	PENDING	PENDING
OIML R137	PENDING	N/A	PENDING

Table 10: Certifications OIML

The declarations of conformity certifying the Heinrichs Messtechnik UMC4 family of transmitters for custody transfer operations can be downloaded from our website at www.heinrichs.eu, or is available upon request.

For further documentation, please contact Heinrichs Messtechnik sales or service department.

6.4 Patents

Patent Pending

7. Operation

7.1 Control unit BE4

7.1.1 Introduction

The UMC4 transmitter can be operated either by means of the installed BE4 control unit, a desktop or by laptop computer in conjunction with PDM® software, or via HART® Communicator.

In the following sections, transmitter operation and parameterization are described using the integrated BE4 control unit. To use the control unit the window mounted screw-on lid must be removed.

In Ex hazardous areas, ensure that all relevant safety regulations have been observed before opening the window lid.

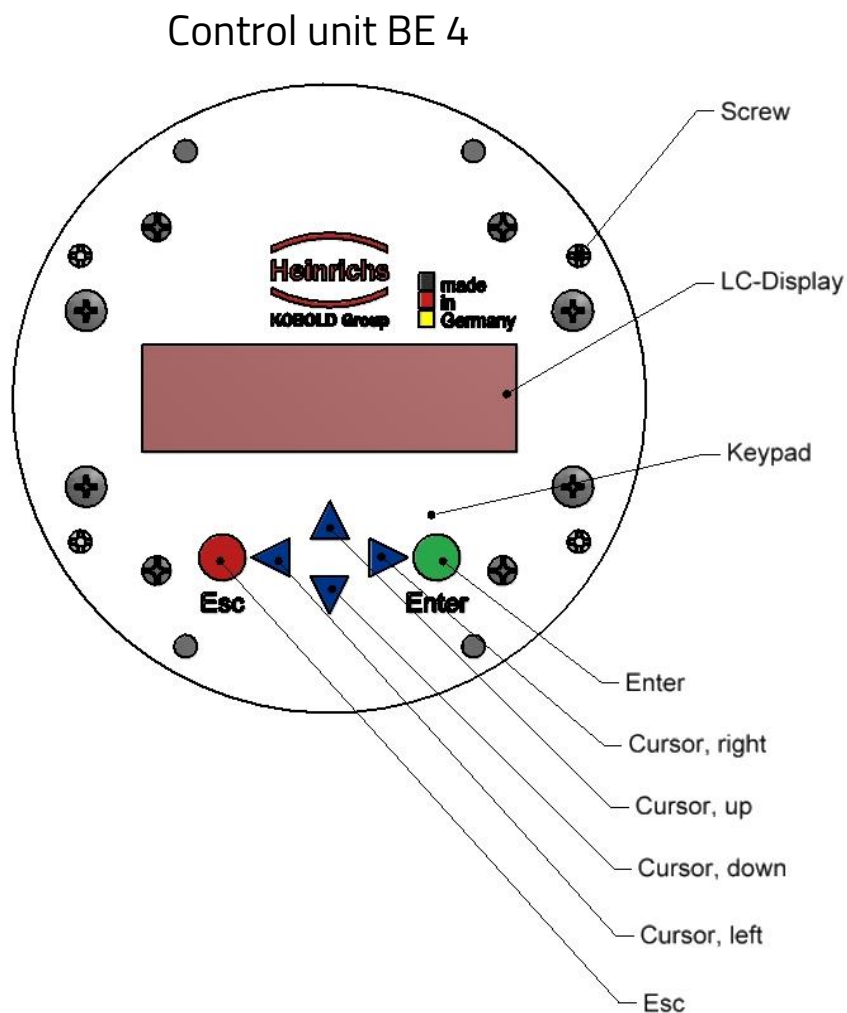

Image 4: Description of the Control unit BE4

The Control unit BE4 has an integrated alphanumeric display with two 16-character lines (format 15 x 52 mm). To improve the readability of the display at low ambient brightness, it is equipped with a backlight. Measurement data and settings can be read directly from this display.

7.1.2 Operating modes

The UMC4 can be operated in the following modes:

1. Display mode: In display mode, measured values can be displayed in various combinations and UMC4 settings can also be displayed. Parameter settings cannot be changed in this mode. Display mode is the standard (default) operating mode when the device is powered up.

2. Programming mode: In programming mode, UMC4 parameters can be redefined. After entering the correct password, changes that are permissible for the customer (customer password) or all functions (service password for technicians) can be realized.

7.1.3 Operator interface

Functional classes are displayed as headings beneath which displays and parameters are shown in logical groups.

Beneath this is the **menu level**, which lists all measured value displays or the headings for their underlying parameters (**parameter level**).

All functional classes are interlinked horizontally, while all sub-menus that are assigned to a functional class are displayed beneath the relevant class.

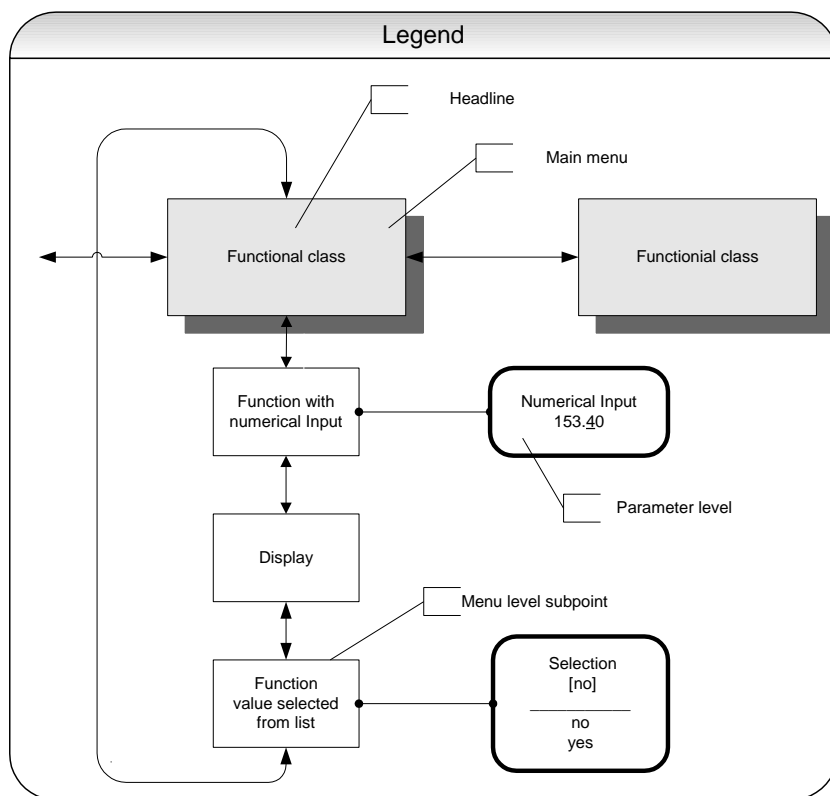

7.1.4 The keys and their functions

There are six keys available for navigating through the menus and amending settings.



Caution:

Using sharp or sharp-edged objects such as pencils or screwdrivers to press the keys may cause irreparable damage.

Cursor keys: Using the cursor keys, the operator can change numerical values, give YES/NO answers and select parameters. Each key is assigned a symbol as stated in the following table:

Descriptor	Symbol
Cursor key, arrow to the right	▶
Cursor key, arrow to the left	◀
Cursor key, arrow to the top	▲
Cursor key, arrow to the bottom	▼

Table 11: Key Assignment Control Unit

Esc key: **The "Esc" key allows you to cancel the current action.** Pressing "Esc" moves you to the next higher level.
Pressing **"Esc"** twice moves you directly to the MEASURED VALUES functional class.

ENTER key: Pressing the "Enter" key moves you from the menu level to the selected Sub-menu parameter level..

All entries are acknowledged with the "Enter" key.

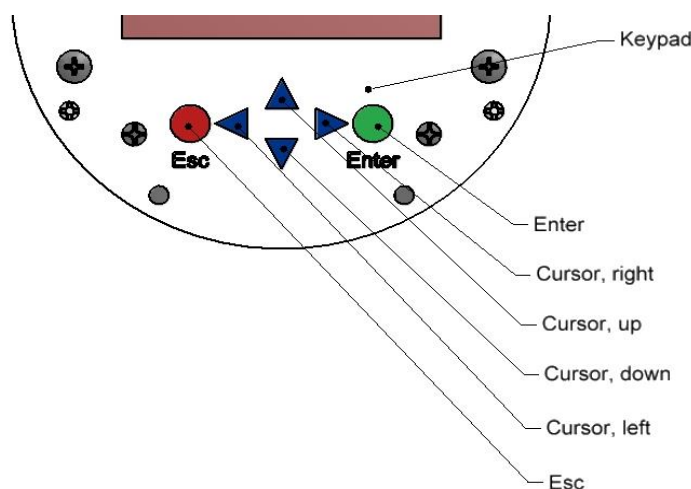

Image 5: BE4 Control unit Push-button description

7.1.5 Functional classes, functions and parameters

Functional classes are written in all upper case letters (headings). The functions beneath each functional class are written in upper and lower case.

The various functional classes and functions are describes in Section 7.2, "UMC4 transmitter function" starting on page 47.

The lower line contains the following elements:

- Informational texts
- YES/NO answers
- Alternative values
- Numerical values (with dimensions, if applicable)
- Error messages

If the user attempts to modify values for any of these parameters without entering the required password, the message "Access denied" will be displayed (see also 7.1.2, "Operating modes" on page 43 and 7.1.5.3, "Passwords" on page 46).

7.1.5.1 Selection window/make a selection

In the selection window, the first line of the LCD always contains the heading, while the second line displays the current setting. This setting is shown in square brackets if the system is in Programming mode.

Function name [Selection]

In Programming mode (see 7.1.2, "Operating modes" on page 43), i.e. after a password has been entered (see 7.1.5.3, "Passwords" on page 46), the operator can navigate to the desired setting by using the ▲ key or the ▼ key and the operator can then confirm your selection by pressing "Enter". To retain the current setting, press "Esc".

7.1.5.2 Input window/modify a value

In the input window, the first line of the LCD always shows the heading, while the second line shows the current setting.

Example:

Function name
-4,5 <u>6</u> 7 Unit

These modifications can only be made in Programming mode (refer to 7.1.2, "Operating modes" on page 43), which means that a correct password (see 7.1.5.3, "Passwords" on page 46) must be entered. To move the cursor from one decimal place to the next, use the ◀ or ▶ keys. To increase the value of the decimal place just under the cursor by "1," use the ▲ key, and use ▼ key to lower the number by 1. To change the minus and plus sign, place the cursor in front of the first digit. To confirm and apply the change, press "Enter". To retain the current value, press "Esc".

7.1.5.3 Passwords

Programming mode is password protected. The customer password allows all changes to be made that are permissible for customers. This password can be changed when the device is first put into operation. Should the password be changed, retain the new password in a safe place.

The UMC4 customer password in the device when delivered is **0002**.

The service password allows for modification of all UMC4 functions. This password is not given to customers.

For further information on customer passwords, see Section 7.2.2, "PASSWORD functional class" on page 53.

7.1.6 Display

The LCD display is designed for operation at temperatures ranging from - 20 °C to + 60 °C (-4 °F to 140 °F) without incurring any damage. However, at freezing or near-freezing temperatures, the display becomes slow and readability of the measured values is reduced. At temperatures below - 10 °C (14 °F), only static values (parameter settings) can be displayed. At temperatures exceeding 60 °C (140 °F), contrast decreases substantially. When submitted to higher temperatures for long periods of time, the liquid crystals may dry out.

7.2 UMC4 transmitter functional classes

The software functions of the UMC4 transmitter are divided into functional classes, are arrayed in a circle and can be navigated by using the ◀ or ▶ cursor keys. To go back to your starting point (the MEASURED VALUES functional class) press "Esc".

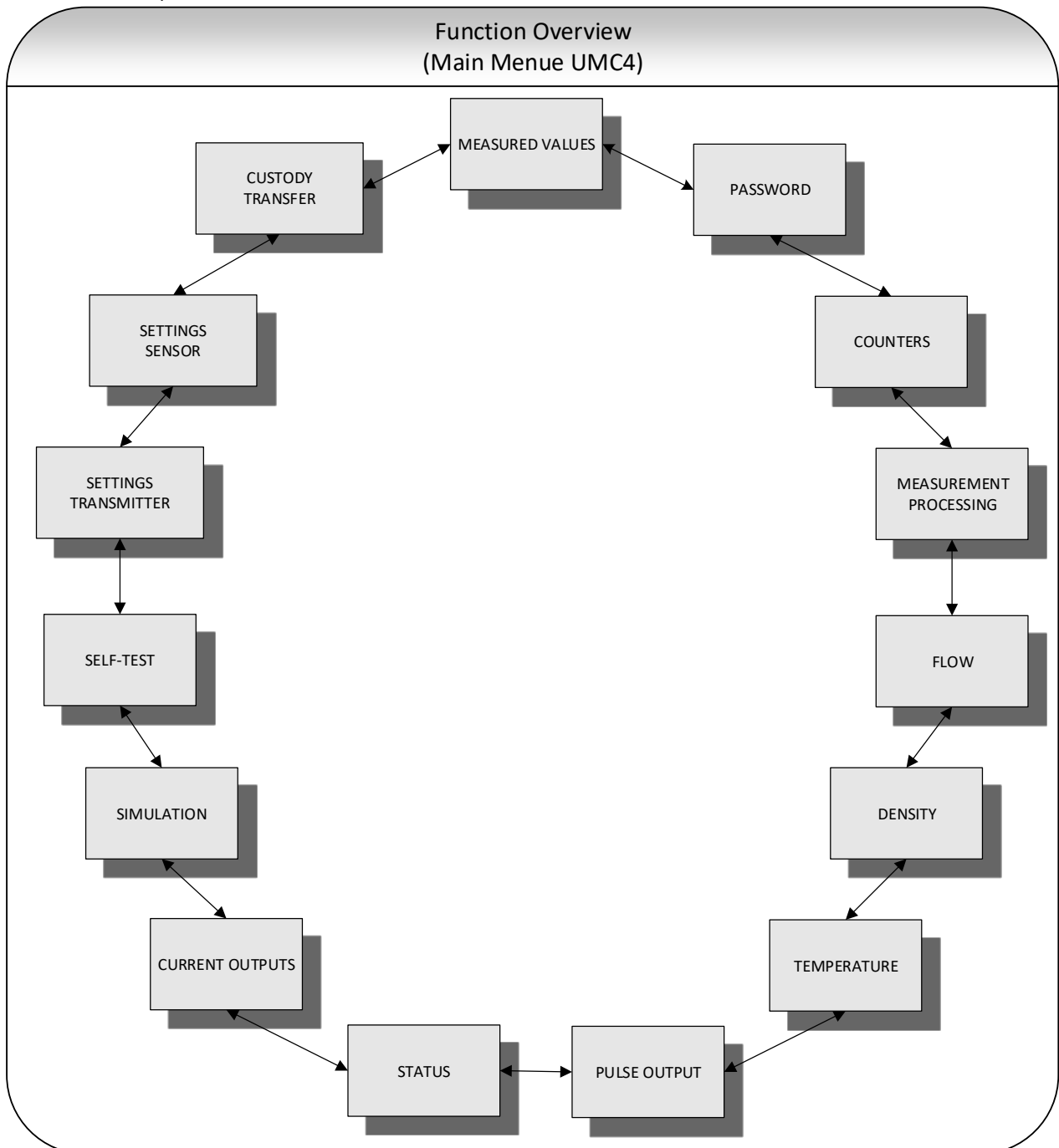

In the following, all software functions that can be accessed using the customer password are described. Functions that are only accessible to the vendor (service functions) are not described in the present document.

7.2.1 MEASURED VALUES functional class

The MEASURED VALUES functional class contains all functions for displaying the measured values.

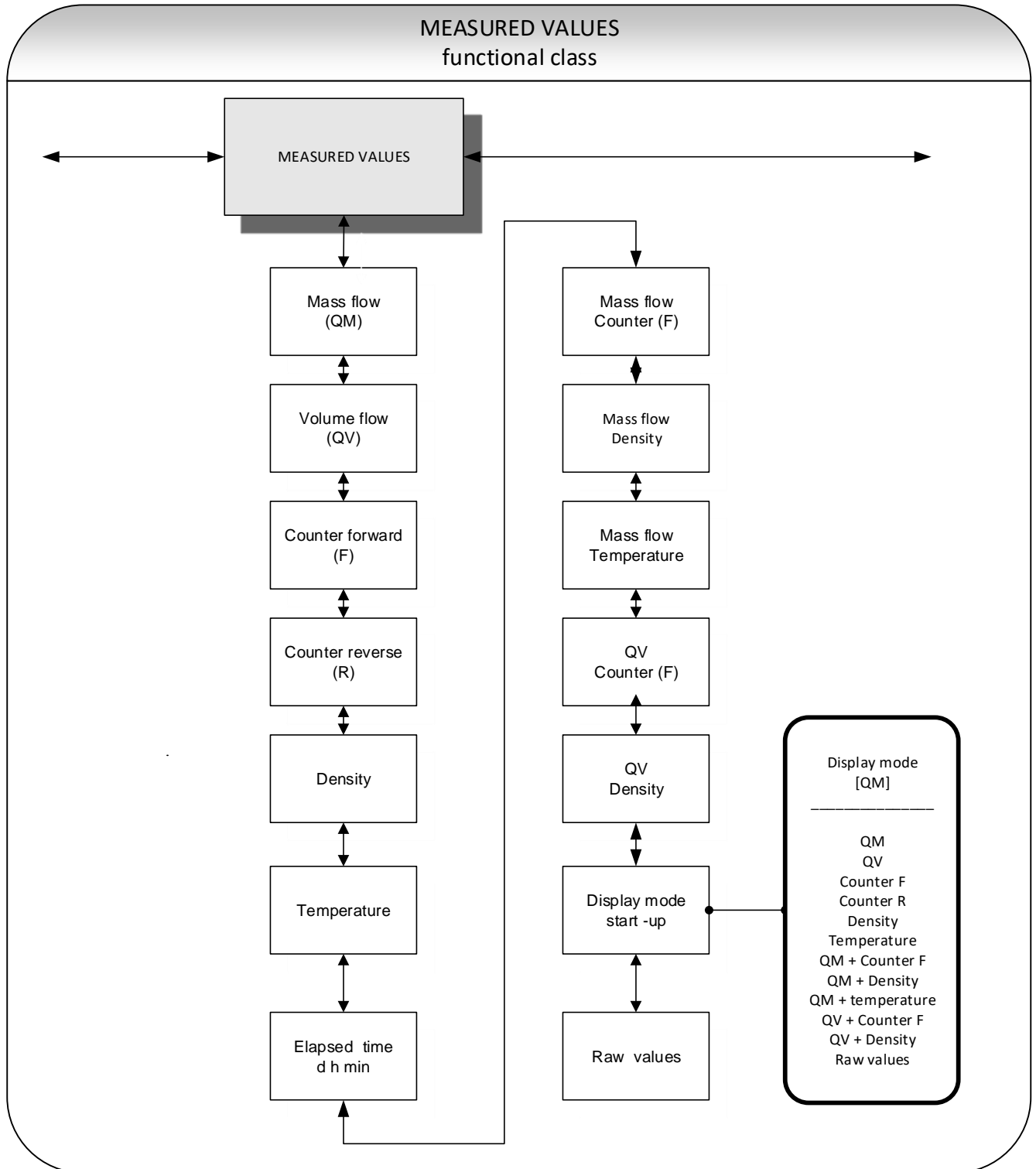

7.2.1.1 Mass flow

After selecting the Mass flow function, the following will be displayed:

Mass flow XXX.X kg/h

The LCD shows the current mass flow. The operator can define the display unit in the FLOW functional class using the *Mass flow QM unit* function.

7.2.1.2 Volume flow

After selecting the *Volume flow* function, the following will be displayed:

Volume flow XXX.X m ³ /h
--

Volume flow can only be displayed if density measurement has been calibrated and activated. Otherwise, an error message is displayed. The operator can define the display unit in the FLOW functional class using the *Volume flow QV unit* function.

7.2.1.3 Counter forward

After selecting the *Counter forward* function, the current reading of the forward flow counter will be displayed.

Counter forward XXXXXXXX.XX kg

The operator can define the display unit in the COUNTERS functional class using the *Unit of counters* function.

7.2.1.4 Counter reverse

After selecting the *Counter reverse* function, the current reading of the reverse flow counter will be displayed.

Counter reverse XXXXXXXX.XX kg

The operator can define the display unit in the COUNTERS functional class using the *Unit of counters* function.

7.2.1.5 Density

Depending on the settings in the DENSITY functional class, the process or reference density will be displayed. Density can only be displayed if the sensor is suitable for density measurement and has been calibrated accordingly.

Density XXX.X g/l

The operator can define the display unit in the DENSITY functional class using the *Density unit* function.

7.2.1.6 Temperature

After selecting the *Temperature* function, the following will be displayed:

Temperature XXX,XX °C

The LCD shows the current temperature of the measured fluid in degrees Celsius, Fahrenheit or Kelvin.

7.2.1.7 Elapsed time

The LCD shows the operating time that has elapsed in d(ays), h(ours) and min(utes) since the system was initialized and commissioned by the vendor:

Elapsed time 256 d 18 h 06 min

7.2.1.8 Mass flow + Counter forward

After selecting the *Mass flow + Counter forward* function, the current mass flow will be displayed in the first line of the LCD:

XXX.X kg/h XXXXXXXX.XX kg

The second line shows the value of the counter forward. The operator can define the display unit in the FLOW functional class using the *Mass flow QM unit* function and the counter unit using the *Unit of counters* function in the COUNTERS functional class.

7.2.1.9 Mass flow + Density

After selecting the *Mass flow + Density* function, the following will be displayed:

XXX.X kg/h XXX.X g/cm ³

The first line of the LCD shows the current mass flow and the second the density of the measured fluid. You define the display unit in the FLOW functional class using the *Mass flow QM unit* function and the density unit using the *Density unit* function in the DENSITY functional class.

7.2.1.10 Mass flow + Temperature

After selecting the *Mass flow + Temperature* function, the following will be displayed:

XXX.X kg/h XXX °C

The first line of the LCD shows the current mass flow and the second line the temperature of the measured fluid. You define the display unit in the FLOW functional class using the *Mass flow QM unit* function.

7.2.1.11 Volume flow + Counter forward

After selecting the *Volume flow + Counter forward* function, the current mass flow will be displayed in the first line of the LCD:

XXX.X m ³ /h XXXXXXXX.XX m ³

The second line shows the value of the counter forward. The operator can define the display unit in the FLOW functional class using the *Volume flow QV unit* function and the counter unit using the *Unit of counters* function in the COUNTERS functional class.

7.2.1.12 Volume flow + Density

After selecting the *Volume flow + Density* function, the following will be displayed:

XXX.X m ³ /h XXX.X g/cm ³
--

The first line of the LCD shows the current volume flow and the second line the density of the measured fluid. The operator can define the display unit in the FLOW functional class using the *Volume flow QM unit* function and the unit for density measurement in the DENSITY functional class using the *Density unit* function.

7.2.1.13 Display mode during startup

By choosing the *Display mode during startup* function the operator can define the default display. After the operator switched the device on and did not touch any keys for a longer period of time, the defined default display will be shown:

Display mode [QM]

One of the following default displays can be selected.

- QM (Mass flow)
- QV (Volume flow)
- Counter f(orward)
- Counter r(everse)
- Density
- Temperature
- QM + Counter f
- QM + Density
- QM + Temperature
- QV + Counter f
- QV + Density
- and Raw values

7.2.1.14 Raw values

The "Raw values display" supports fault diagnosis and trouble shooting. Please inform our service department about the clear text error messages and the contents of this "Raw values display."

xxx.xxx	ttt.tttt
fff.ffff	eee.aaa

The displayed values have the following meaning:

xxx.xxx: Measure for the phase displacement between the sensor signals.

ttt.ttt: Indicates the measured sensor temperature.

fff.ffff: Indicates the current oscillation frequency of the system.

eee.aaa: Indicates the value of the excitation current (eee) and the sensor voltage (aaa).

7.2.2 PASSWORD functional class

The PASSWORD functional class is comprised of the functions for entering and changing the customer password and entering the service password. To cancel the current action, press "Esc".

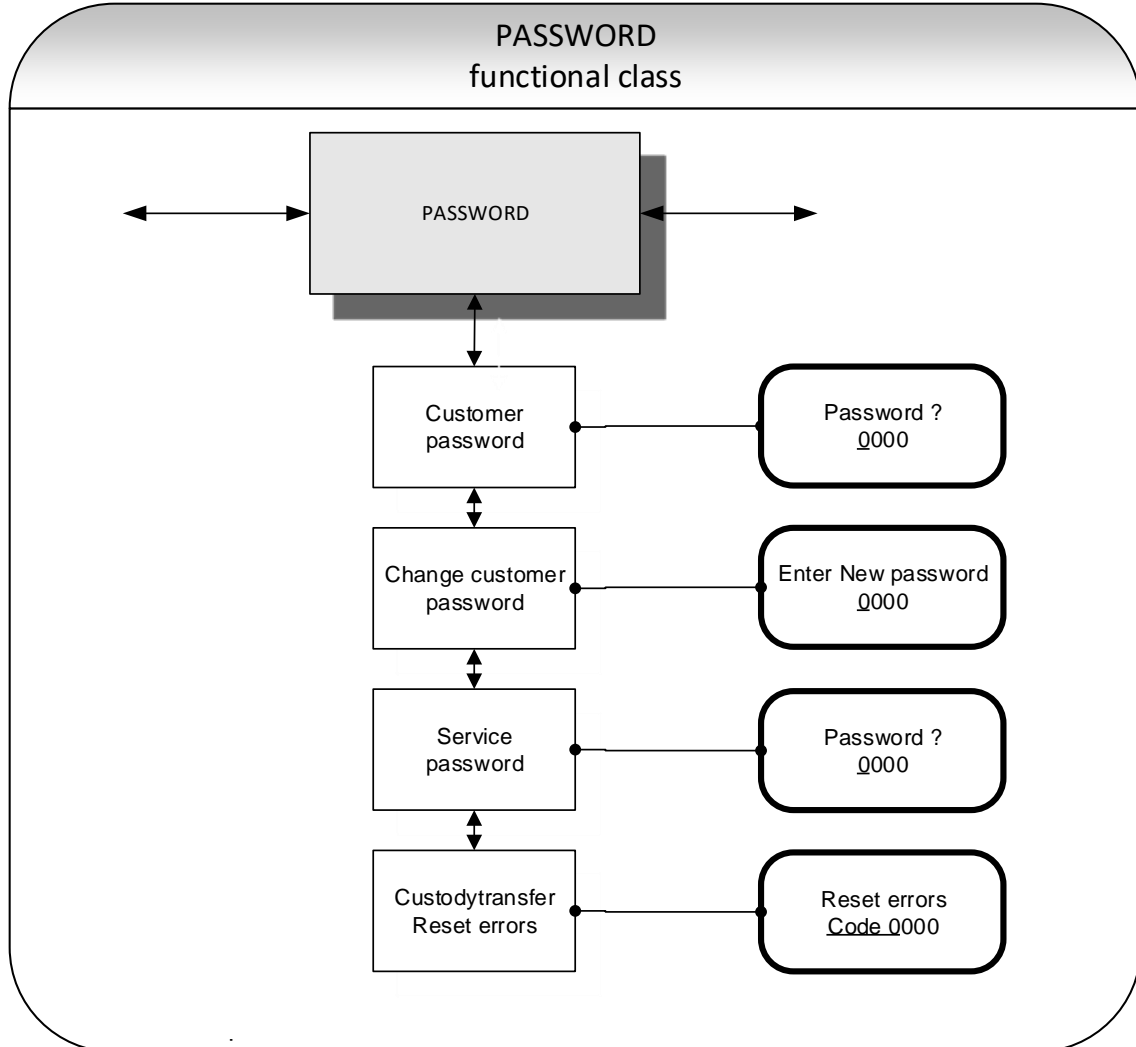

7.2.2.1 Customer password

After selecting the *Customer password* function and pressing "Enter", the following will be displayed:

Password?
0000

The numbers **0000** are displayed and can be changed by toggling the arrow keys as description in section 7.1.5.2, "Input window/modify a value".

Pressing the "Enter" key verifies the password.

If the entered password is correct, the following message will be displayed:

Password
valid

If the entered password is incorrect, the following message will be displayed:

Password
invalid

The customer default password upon delivered is **0002**.

A valid customer password allows all software parameter changes to be made that are permissible for customers. After the operator switched the device off or did not touch any keys for about 15 minutes, the authorization to change settings related to password entry will automatically be cancelled. If the operator does not enter a valid password, all settings can be displayed but not changed. Parameter changes via HART or Profibus PA may be carried out any time without entering password.

7.2.2.2 Change customer password

After entering a valid customer password, you may change the existing password and enter a new one. After selecting the *Change customer password* function and pressing "Enter", the following will be displayed.

Enter New password
0000

The numbers **0000** are displayed and can be changed by toggling the arrow keys as description in section 7.1.5.2, "Input window/modify a value".

Pressing the "Enter" key confirms the new password.



Note:

Press "Enter" to confirm and save the new password. Make sure that you entered the desired password.

A copy of the password should be kept in a safe place.

Reactivation of a transmitter at the vendor's site due to a lost password is not part of our warranty.

7.2.2.3 Service password

You do not need the service password for setting the functions necessary for operation.

The service password is reserved for service technicians and not provided to customers. Correct settings are essential for proper operation of the device (e.g. parameterization and calibration values).

7.2.3 COUNTER functional class

The COUNTERS functional class is comprised of the following functions:

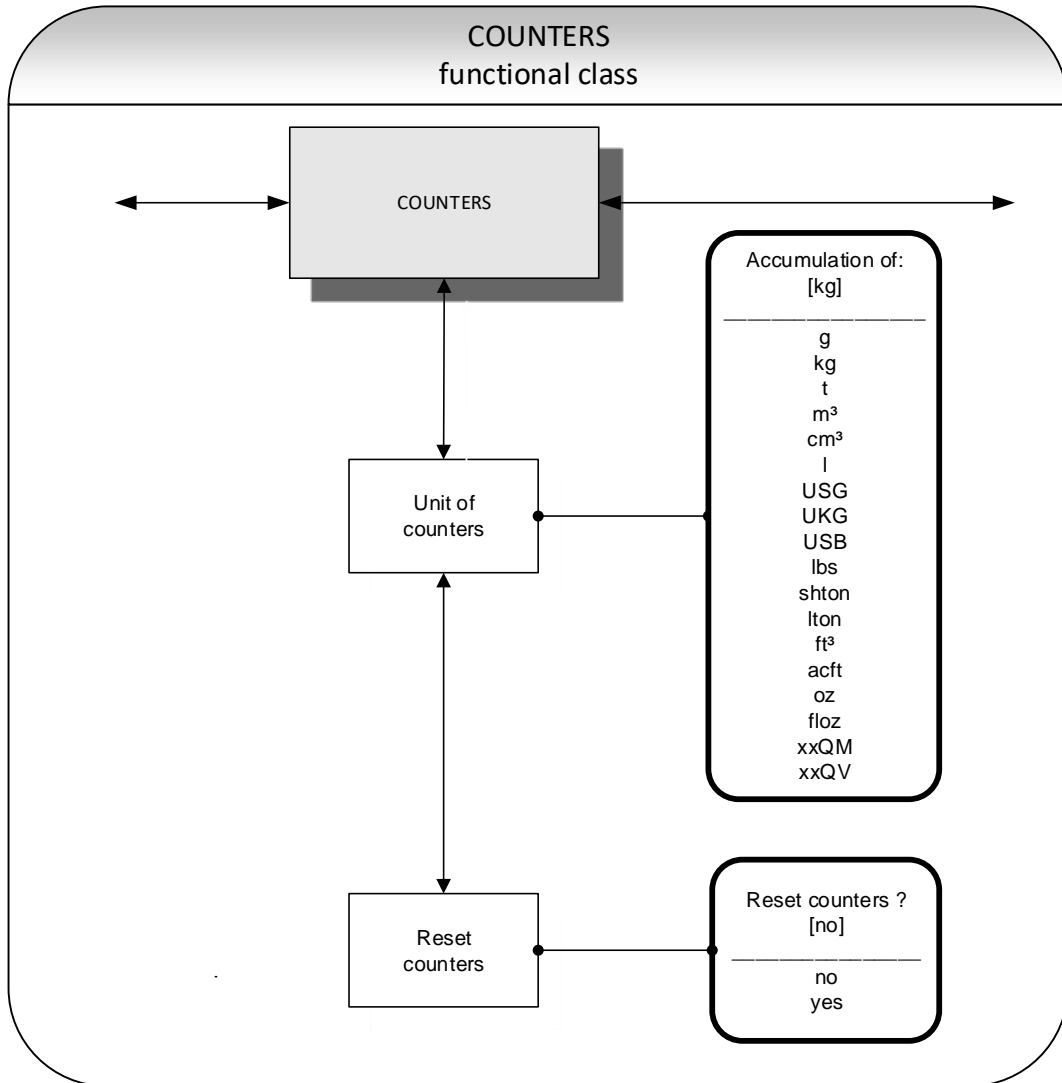

To change the current settings, enter the customer password. Otherwise, the settings can only be displayed but not changed. To cancel the current action, press "Esc".

7.2.3.1 Unit of counters

After choosing the Unit of counters function and pressing "Enter", the current forward and reverse counter unit will be displayed:

Accumulation of:
[kg]

One of the following units can be selected.

- Mass units: g, kg, t, lbs, shton, lton and oz
- Volume units: m³, cm³, l, USG, UKG, USB, ft³, acf and floz
- Programmable mass unit: xxQM,
- Programmable volume unit: xxQV.

When the unit is changed, the counters will be reset to 0.00 automatically.

The volume unit only makes sense if the sensor has been calibrated for density measurement. Press "Enter" to confirm and save the selection. Forward and reverse counters will now show the selected unit.

The valence of the programmable units are defined by the settings of the flow units described in sections 7.2.5.2, "Factor mass flow QM programmable unit" on page 62 and 7.2.5.8, "Factor volume flow QV programmable unit" on page 65.

7.2.3.2 Reset counters

To reset the totalizing counters, you need to toggle to [yes]. Forward and reverse counters will be reset at the same time (0.00).

Reset counters
[no]

By pressing "Esc" or toggling to [no] the operator can cancel the current action without changing the counter readings.

7.2.4 MEASUREMENT PROCESSING functional class

The MEASUREMENT PROCESSING functional class is comprised of all functions that affect the processing of the measured values.

To change the current settings, enter the customer password. Otherwise, the settings can only be displayed but not changed. To cancel the current action, press "Esc".

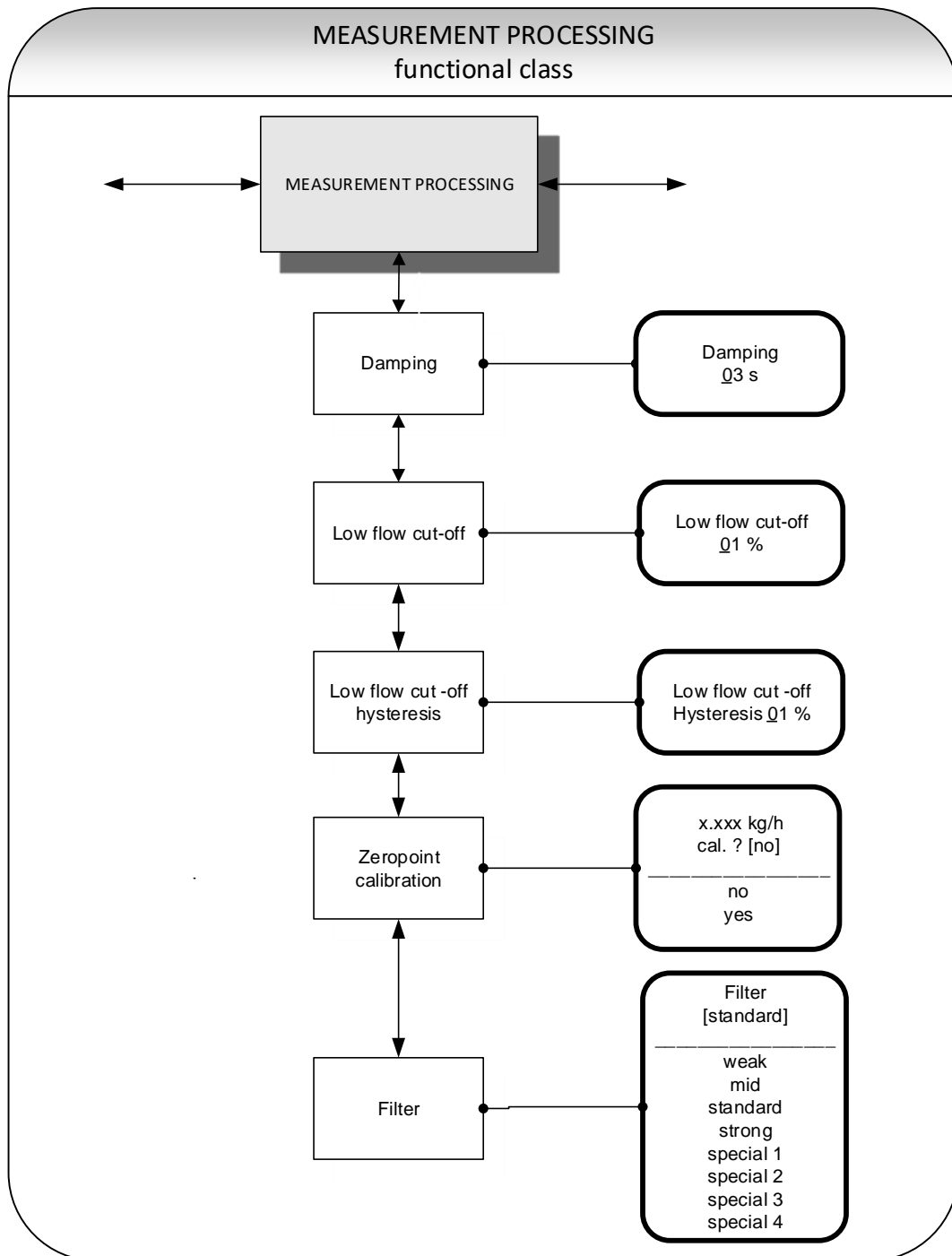

7.2.4.1 Damping

The damping value is intended to dampen abrupt flow rate changes or disturbances. It affects the measured value display and the current and pulse outputs. It can be set in intervals of 1 second from 1 to 60 seconds. After choosing the Damping value function and pressing "Enter", the following selection field will be displayed:

Damping 03 s

The current damping value will be displayed and can be changed by toggling the arrow keys. Pressing the "Enter" key confirms the entry.

7.2.4.2 Low flow cut-off

The value for low flow cut-off (low flow volume) is a limiting value stated as a percentage that relates to the upper-range value of the flow rate. If the volume drops below this value (e.g. leakage), the displayed value and the current outputs will be set to "ZERO." The value for low flow cut-off can be set from 0 to 20 % in 1-percent increments. After choosing the *Low flow cut-off* function and pressing "Enter", the following selection field will be displayed:

Low flow cut-off 00 %

The low flow volume will be displayed and can be changed by toggling the arrow keys. After setting the new low flow volume, you confirm your entry with "Enter".

For devices used in custody transfer operations, you need to deactivate the low flow cut-off function, i.e. to set this value to 0 %.

7.2.4.3 Low flow cut-off hysteresis

The hysteresis of the low flow volume is the flow rate expressed as a percentage of the upper range value by which the volume must fall below or surpass the set low flow volume in order to activate or deactivate the function. The hysteresis of the low flow volume can be set in 1-percent increments from 0 to 10 %. After selecting the Low flow cut-off hysteresis function and pressing "Enter", the following selection field will be displayed:

Low flow cut-off
Hysteresis 00 %

The current hysteresis will be displayed and can be changed by toggling the arrow keys. Pressing the "Enter" key confirms the entry

7.2.4.4 Zero point calibration

Using the Zero point calibration function the operator can recalibrate the zero point of your meter in the measuring system. Zero point calibration is to be realized after any installation procedure or after any type of work has been performed on in the pipes near the sensor.

**Caution:**

It is important that this function is only performed when certain that the medium in the sensor is not moving (flowing). Otherwise, the subsequently measured flow rates will provide an incorrect zero-point. The sensor may be completely empty or filled with medium. A partially filled sensor or a fluid containing air bubbles will lead to an incorrect zero point calibration.

**Note:**

Calibrating a sensor filled with a fluid is preferable than calibrating with empty tubes!

After choosing the Zero point calibration function and pressing "Enter", the current remaining flow will be displayed:

QM = 0,00 kg/h
cal. ? [no]

The operator can toggle between [yes] and [no].

After setting the new value, press "Enter" to confirm your entry. Entering [yes] initiates a new zero point calibration.

7.2.4.5 Filter

For a noise reduction of the actual readings and minimizing disturbances on the sensor lines signal filter are used. Following settings are available:

- weak
- mid
- standard (factory setting)
- strong
- special

Selecting of “weak”, “mid” or standard influences the dynamics of the actual readings just less. The setting of damping time (see section 7.2.4.1, “Damping” at page 58 above) determines the dynamic behaviour of sensor and transmitter. Filter “strong” operates as an intense low pass filter to reduce the noise of the actual readings. Then if setting the damping time shorter than 3 seconds, the low pass filter determines the dynamic behaviour to actual reading’s variations.



Note:

Setting of the filters “special 1” to “special 4” is carried out by the manufacturer. These filter characteristics are optimized for specific custom applications, defined by the manufacturer. Using these filters in standard applications, can result in a degrading of the measurement signal! To use of these filters, consult the manufacturer.

The operator can toggle between noise filter types with the arrow keys. After setting the new filter type, press “Enter” to confirm your entry.

7.2.5 FLOW functional class

The FLOW functional class is comprised of functions that affect lower- and upper-range values and the processing of the measured flow rates. In Programming mode (see 7.1.2, "Operating modes"), i.e. after a password has been entered (see 7.1.5.3, "Passwords" and 7.2.2, "PASSWORD functional class"), the operator can change the settings regarding flow. To cancel the current action, press "Esc".

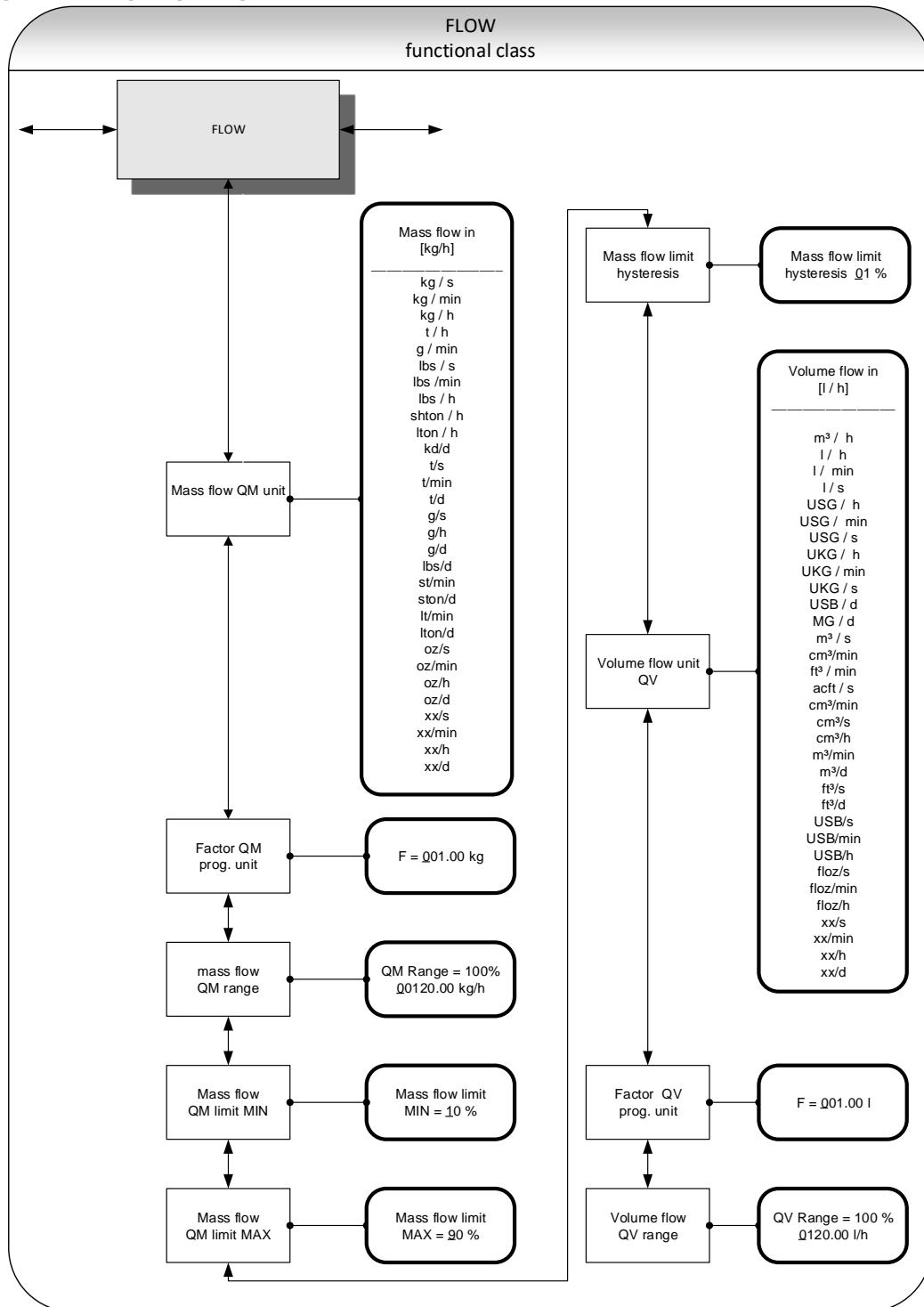

7.2.5.1 Mass flow QM unit

Using this function, the operator can define the physical unit for all display functions, limit values and the upper-range value of mass flow. After choosing the *Mass flow QM unit* function and pressing "Enter", the following selection field will be displayed:

Mass flow QM unit
[kg/h]

One of the following units can be selected:

- kg/s, kg/min, kg/h, kg/d,
- t/s, t/min, t/h,t/d,
- g/s, g/min, g/h, g/d,
- lbs/s, lbs/min, lbs/h,lbs/d,
- shton/min, shton/h, shton/d,
- lton/h, lton/min, lton/d,
- oz(s, oz/min, oz/h, oz/d,
- xx/s, xx/min, xx/h, xx/d (programmable mass flow unit)

Press "Enter" to confirm and save the selection.

A conversion factor can be entered as a substitute for a not available mass flow unit as described in the after-following chapter 7.2.5.2, "Factor mass flow QM programmable unit" on page 62. In this case the unity xx is selected into combination with the desired time unit.

7.2.5.2 Factor mass flow QM programmable unit

To display another mass flow unity than one of the predefined standard units a factor can be entered for the conversion of the reading.

F = 001.0 kg

The factor always refers to the unity of kg.

A new factor can be entered by toggling the arrow keys.
Pressing the "Enter" key confirms the entry.

7.2.5.3 Mass flow QM range

This function allows the operator to set the upper-range value for mass flow. The upper-range value takes on the unit defined using the *Mass flow unit* function. The upper-range value will scale the current and frequency outputs assigned to mass flow. After choosing the *Mass flow QM range* function and pressing "Enter", the following selection field will be displayed:

QM range=100%
XXXXX.XX kg/h

The current upper-range value for mass flow will be displayed and can be changed by toggling the arrow keys. Pressing the "Enter" key confirms the entry.

7.2.5.4 Mass flow QM limit MIN

The MIN limiting value for mass flow can be evaluated via the status output. You enter the value as a percentage of the set upper-range value. If the mass flow is lower than that limit value, the status output will be set in case the corresponding assignment has been made. If the alarm function has also been activated for the assigned current output, the applied current will change to < 3.2 mA or > 20.5 mA / 22 mA. After choosing the *Mass flow QM limit MIN* function and pressing "Enter", the following selection field will be displayed:

Mass flow limit
MIN = 10 %

The current MIN upper-range value for mass flow will be displayed and can be changed by toggling the arrow keys.

Pressing the "Enter" key confirms the entry.

7.2.5.5 Mass flow QM limit MAX

The MAX limiting value for mass flow can be evaluated via the status output. You enter the value as a percentage of the set upper-range value. If the mass flow surpasses this limit value, the status output will be set in case the corresponding assignment has been made. If the alarm function has also been activated for the assigned current output, the applied current will change to < 3.2 mA or > 20.5 mA / 22 mA. After choosing the *Mass flow QM limit MAX* function and pressing "Enter", the following selection field will be displayed:

Mass flow limit
MAX = 90 %

The current MAX upper-range value for mass flow will be displayed and can be changed by toggling the arrow keys.

Pressing the "Enter" key confirms the entry.

7.2.5.6 Mass flow QM limit hysteresis

The hysteresis of the QM limiting values is the flow rate in percent based on the upper-range value and indicates the value which must fall below or surpass the set limiting values in order to activate or deactivate the function. The hysteresis of the QM limiting values can be set in 1-percent increments from 0 to 10 %. After choosing the *Mass flow QM limit hysteresis* function and pressing "Enter", the following selection field will be displayed:

Mass flow limit
Hysteresis 00 %

The current hysteresis value will be displayed and can be changed by toggling the arrow keys. Confirm the entry with "Enter".

7.2.5.7 Volume flow QV unit

This function allows the operator to define the physical unit for all display functions and the upper-range value for volume flow. After choosing the "Volume flow QV unit" function and pressing "Enter", the following selection field will be displayed:

Volume flow QV unit
in [m³/h]

One of the following units can be selected:

- m³/d, m³/h, m³/min, m³/s, cm³/h, cm³/min, cm³/s
- l/h, l/min, l/s,
- USG/h, USG/min, USG/s,
- UKG/h, UKG/min, UKG/s
- USB/d, USB/h, USB/min, USB/s,
- MG/d
- ft³/d, ft³/min, ft³/s
- acft/s
- floz/h, floz/min, floz/s
- xx/h, xx/min, xx/h.

Press "Enter" to confirm and save the selection.

A conversion factor can be entered as a substitute for a not available mass flow unit as described in the after-following chapter 7.2.5.8, "Factor volume flow QV programmable unit" on page 65. In this case the unity xx is selected into combination with the desired time unit.

7.2.5.8 Factor volume flow QV programmable unit

To display another volume flow unit than one of the predefined standard units a factor can be entered for the conversion of the reading.

F = 001.0 l

The factor always refers to the unit of l.

The Factor value for volume flow will be displayed and can be changed by toggling the arrow keys. Pressing the "Enter" key confirms the entry.

7.2.5.9 Volume flow QV range

This function allows the operator to set the upper-range value for volume flow. The upper-range value takes on the unit defined using the *Volume flow QV unit* function. After choosing the *Volume flow QV range* function and pressing "Enter", the following selection field will be displayed:

QV range=100 %
XXXXX.XX m³/h

The current upper-range value for volume flow will be displayed and can be changed by toggling the arrow keys.

Pressing the "Enter" key confirms the entry.

Output and display of the measured value is only possible for mass flowmeters for which received a density calibration.

7.2.6 DENSITY functional class

The functional class DENSITY is comprised of the functions that affect the lower- and the upper-range value and the processing of the measured density values. The additional service functions regarding density calibration will not be described in these instructions.

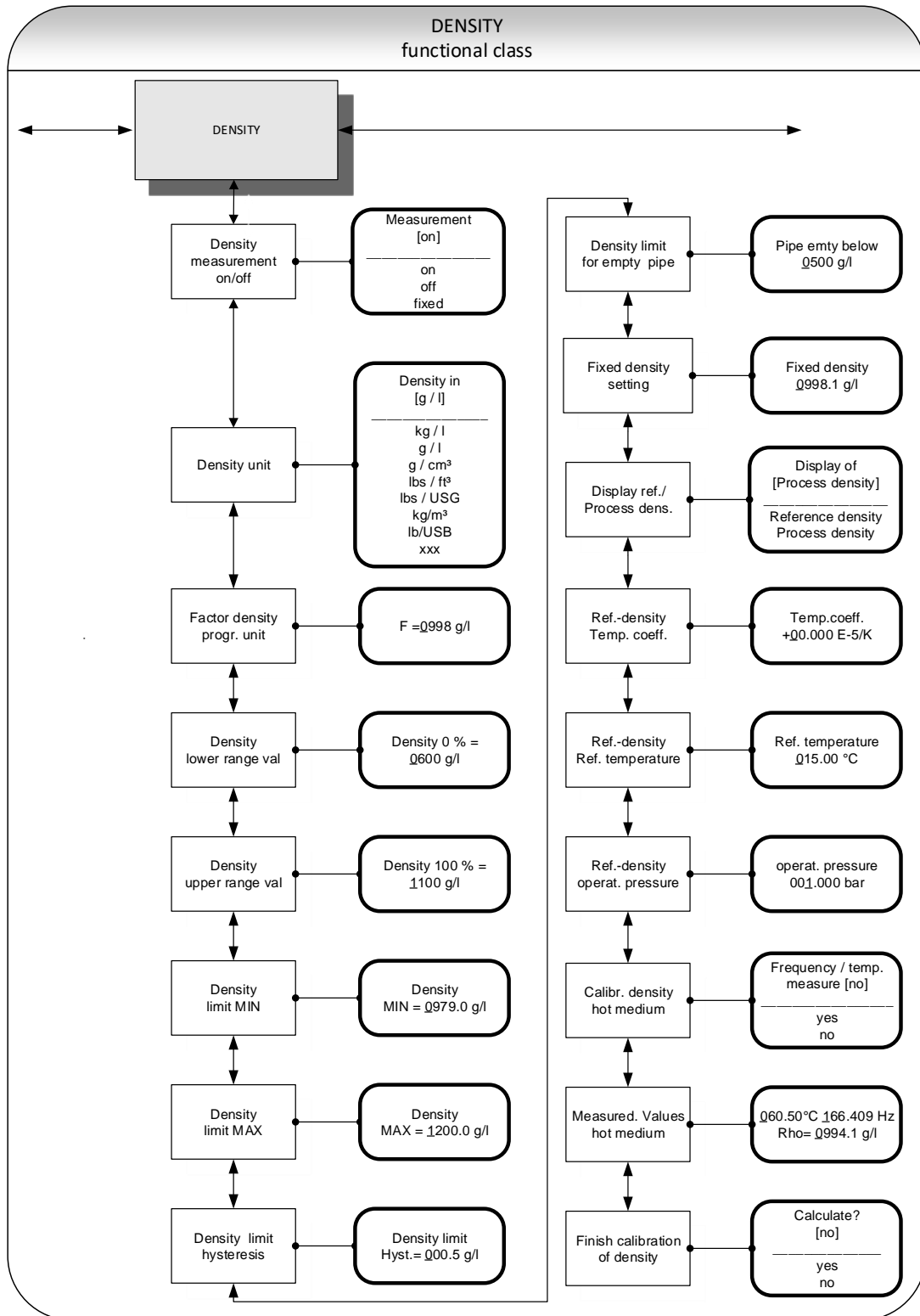

7.2.6.1 Density measurement on/off

This function allows the operator to activate density measurement. After selecting the *Density measurement* on/off function, press "Enter" to display the following selection field:

Measurement
[on]

The operator can choose between the following settings:

- on density measurement is switched on
- off density measurement is switched off
- fixed density measurement is switched off; a fixed replacement value will be displayed and used for calculating the volume flow

To confirm and apply the selection, press "Enter".

If density measurement is switched on and the message "Density not calibrated" is displayed, no density calibration was carried out by the vendor.

**Note:**

Density measurement can only be activated if density calibration has been performed. If no density calibration has been performed, the density and volume flow values will be set to "0.0" in the MEASURED VALUES functional class and the message "Density unknown" will be displayed

7.2.6.2 Density unit

This function allows the operator to define the physical unit for all display functions and the density lower- and upper-range value. After selecting the *Density unit* function, press "Enter" to display the following selection field:

Density unit
[g/l]

The operator can choose between the following units:

- g/l, kg/m³
- kg/l
- g/cm³
- lbs/ft³
- lbs/USG, lbs/USB
- xxx

Press "Enter" to confirm and apply the selection.

A conversion factor can be entered as a substitute for a not available density as described in the after-following section 7.2.6.3, "Factor programmable density unit" on page 68.

7.2.6.3 Factor programmable density unit

To display another density unit than one of the predefined standard units a factor can be entered for the conversion of the reading.

F = 0998.0 g/l

The factor always refers to the unity of g/l.

The Factor value for density will be displayed and can be changed by toggling the arrow keys. Pressing the "Enter" key confirms the entry.

7.2.6.4 Density lower-range value

This function allows the operator to define the lower-range value for density measurement in the selected unit. If density is equal or below this value, the assigned current output will be set to its initial value of 0/4 mA.

After selecting the *Density lower-range value* function, press "Enter" to display the following selection field:

Density 0 % =
XXXXX g/l

The current lower-range value will be displayed and can be changed by toggling the arrow keys. Confirm the entry with "Enter".

7.2.6.5 Density upper-range value

This function allows the operator to define the upper-range value for density measurement in the selected unit. For this density, the assigned current output will be set 20 mA. The applied current of the current output assigned to the density value is linearly interpolated based on the ratio between the measured value and the difference between lower- and upper-range value.

After selecting the *Density upper-range value* function, press "Enter" to display the following selection field:

Density 100 % =
XXXXX g/l

The current upper-range value will be displayed and can be changed by toggling the arrow keys. Pressing the "Enter" key confirms the entry.

7.2.6.6 Density limit MIN

The MIN limiting value for density can be evaluated via the status output and thus triggers an external alarm. This value is entered as an absolute value in the unit defined using the *Density unit* function.

After selecting the *Density limit MIN* function, press "Enter" to display the following selection field:

Density limit MIN = 0000.0 g/l

The current MIN limiting value will be displayed and can be changed by toggling the arrow keys. Pressing the "Enter" key confirms the entry.

7.2.6.7 Density limit MAX

The MAX limiting value for density can be evaluated via the status output. This value is entered as an absolute value in the unit defined using the *Density unit* function.

After selecting the *Density limit MAX* function, press "Enter" to display the following selection field:

Density limit MAX = 0000.0 g/l

The current MAX limiting value will be displayed and can be changed by toggling the arrow keys. Pressing the "Enter" key confirms the entry.

7.2.6.8 Density limit hysteresis

The hysteresis of the density limiting values indicates the absolute density value in the unit defined using *Density unit* function. The measured density must fall below or surpass the set limiting values by the set hysteresis value in order to activate or deactivate the function.

After selecting the *Density limit hysteresis* function, press "Enter" to display the following selection field:

Density limit Hysteresis 000.0 g/l

The current limit hysteresis value will be displayed and can be changed by toggling the arrow keys. Pressing the "Enter" key confirms the entry.

7.2.6.9 Density limit for empty pipe

If the measured density or the fixed value falls below this limiting value, the message "Empty pipe" will be displayed, and an alarm will be triggered.

Press "Enter" to display the following selection field:

Pipe empty below
0500.0 g/l

The current limiting value will be displayed and can be changed by toggling the arrow keys. Pressing the "Enter" key confirms the entry.

7.2.6.10 Fixed density

If the operator selected the *fixed* option described in Section 7.2.6.1, "Density measurement on/off" on page 67, density measurement will be switched off. The replacement value defined in the following selection field will be displayed.

Press "Enter" to display the following selection field:

Fixed density
0998.1 g/l

The current fixed density will be displayed and can be changed by toggling the arrow keys. Pressing the "Enter" key confirms the entry.

The density unit can be defined for all settings and displays as described in Section 7.2.6.2, "Density unit".

7.2.6.11 Reference/process density display

When measuring density in a mass flowmeter, usually process density is displayed. Process density is the density of the fluid at the measured temperature. Reference density can also be displayed as an option. In this case the measured process density will be converted based on a reference temperature. To do so, the reference temperature, the volume temperature coefficient of the fluid and the pressure at reference density (for gases) must be known and have been programmed.

Volume measurement also depends on this setting. If "Process density" is set, the measured volume flow will be displayed. If "Reference density" is set, a volume standardized to the reference density will be displayed.

Display of
[Process density]

The current operating mode for density measurement will be displayed and can be changed between the two modes by toggling the arrow keys.

Pressing the "Enter" key confirms the entry.

7.2.6.12 Temperature coefficient

In order to calculate the reference density using the process density, the temperature coefficient of the fluid density must be known. In order to improve the resolution and facilitate data entry, the unit of the temperature coefficient is set to 10^{-5} 1/K.

Temp. coeffic. 00.00 E-5/K

The current density temperature coefficient value in 10^{-5} 1/K will be displayed and can be changed between the two modes by toggling the arrow keys.

7.2.6.13 Reference temperature

In order to calculate the reference density, the temperature to which the density relates is needed. The temperature for fuel oil usually is 15 °C.

Ref. temperature 015.00 °C

The reference temperature will be displayed in °C and can be changed by toggling the arrow keys. Pressing the "Enter" key confirms the entry.

7.2.6.14 Operating pressure

This function has been prepared for the consideration of gas equations for the measurement of reference density and volume for gases. In this software version, it will not be used for calculations.

operat. pressure 001.00 bar

The current value process pressure will be displayed in bar and can be changed by toggling the arrow keys. Pressing the "Enter" key confirms the entry.

7.2.6.15 Density calibration hot medium

A single point density calibration can be made with a suitable mass flow sensor by the operator. The procedure is described in detail in chapter 7.3, "Density calibration" at page 105.

With this function the necessary measurement of the resonant frequency and the medium temperature is made. The sensor must be filled with a liquid medium. At a temperature of e.g. 60 °C hot water can be used as harmless medium or for optimal results the process medium under normal operating conditions.

Frequency/temp.
measure? [no]

After selecting [yes] with the arrow keys, press "Enter" and the measurement is executed.

7.2.6.16 Measured values hot medium

The values of the function "Density calibration hot medium" above are displayed in the upper line. Pressing 2 times the green "Enter" confirms them without any change. Afterwards the density of the measured medium has to be entered as reference in the lower line.

60.50°C 166.409 Hz
Rho = 0994,1 g/l

The density is always entered in the unit g/l (equivalently too kg/m³) and if required can be amended by toggling the arrow keys.

7.2.6.17 Finish density calibration

In order to finalise and store the density calibration by both preceding functions it is necessary to complete some internal calculations.

Calculate?
[no]

by toggling the arrow keys switch the displayed option to "yes" and press "Enter". The reference values for the density measurement are then calculated and saved. Furthermore, to activate density measurement the density measurement must be activated as described in section 7.2.6.1, "Density measurement on/off" on page 67.

7.2.7 TEMPERATURE functional class

The TEMPERATURE functional class is comprised of the functions that affect the lower- and the upper-range value and the processing of the measured temperature. The additional service functions shall not be described in this manual. Modifications can only be made in Programming mode (see 7.1.2 Operating modes), which means that a correct password (see 7.1.5.3, "Passwords" and 7.2.2, "PASSWORD functional class") must be entered.

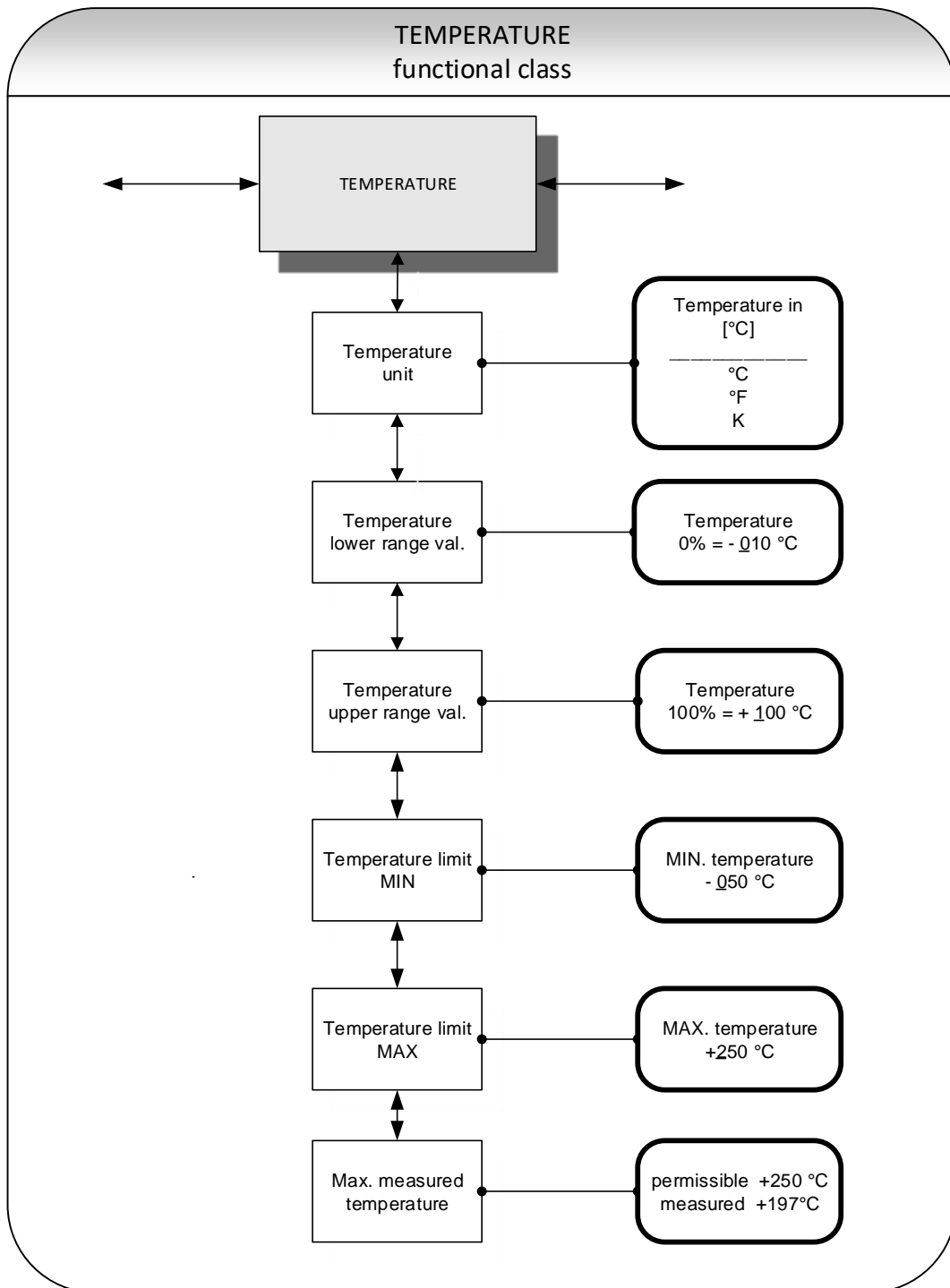

7.2.7.1 Temperature unit

This function allows the operator to set the unit for temperature measurement. Press "Enter" to display the following selection field:

Temperature in
[°C]

The set unit will be displayed and can be changed by toggling the arrow keys.

Pressing the "Enter" key confirms the entry.

All display windows, measuring ranges and limiting values refer to the selected unit.

7.2.7.2 Temperature lower-range value

This function allows the operator to define the lower-range value for temperature measurement. Lower temperatures will set the assigned current output to the minimum value of 0/4 mA. The temperature is entered in the set temperature unit. After selecting the *Temperature lower-range value* function, press "Enter" to display the following selection field:

Temperature
0% = + 005 °C

The current lower-range value for temperature measurement will be displayed and can be changed by toggling the arrow keys.

Pressing the "Enter" key confirms the entry.

7.2.7.3 Temperature upper-range value

This function allows the operator to define the upper-range value for temperature measurement. For this temperature, the assigned current output will be set to the upper-range value of 20 mA. The applied current of the current output assigned to the temperature value is linearly interpolated based on the ratio of the measured value to the difference between lower- and upper-range value.

The temperature is entered in the set temperature unit. After selecting the *Temperature upper-range value* function, press "Enter" to display the following selection field:

Temperature
100 % = +090 °C

The current upper-range value for temperature measurement will be displayed and can be changed by toggling the arrow keys.

Pressing the "Enter" key confirms the entry.

7.2.7.4 Temperature limit MIN

The MIN limiting value for temperature can be evaluated via the status output. This value is entered in the set temperature unit.

After selecting the *Temperature limit MIN* function, press "Enter" to display the following selection field:

MIN temperature -010 °C

The current MIN limiting value will be displayed and can be changed by toggling the arrow keys. If the measured value falls below the limiting value, the "Alarm" status message will be displayed. Pressing the "Enter" key confirms the entry.

7.2.7.5 Temperature limit MAX

The MAX limiting value for temperature can be evaluated via the status output. This value is entered in the set temperature unit.

After selecting the *Temperature limit MAX* function, press "Enter" to display the following selection field

MAX temperature + 250 °C

The current MAX limiting value will be displayed and can be changed by toggling the arrow keys. If the measured value falls below the limiting value, the "Alarm" status message will be displayed. Pressing the "Enter" key confirms the entry.

7.2.7.6 Max. measured temperature

After selecting this display, the largest measured temperature will be displayed. For comparison, the set maximum limiting value will be displayed in the first line.

permissible	+250 °C
measured	+197 °C

This value cannot be reset since it stores the maximum measured process temperature.

7.2.8 PULSE OUTPUT functional class

The PULSE OUTPUT functional class is comprised of the functions regarding the pulse output.

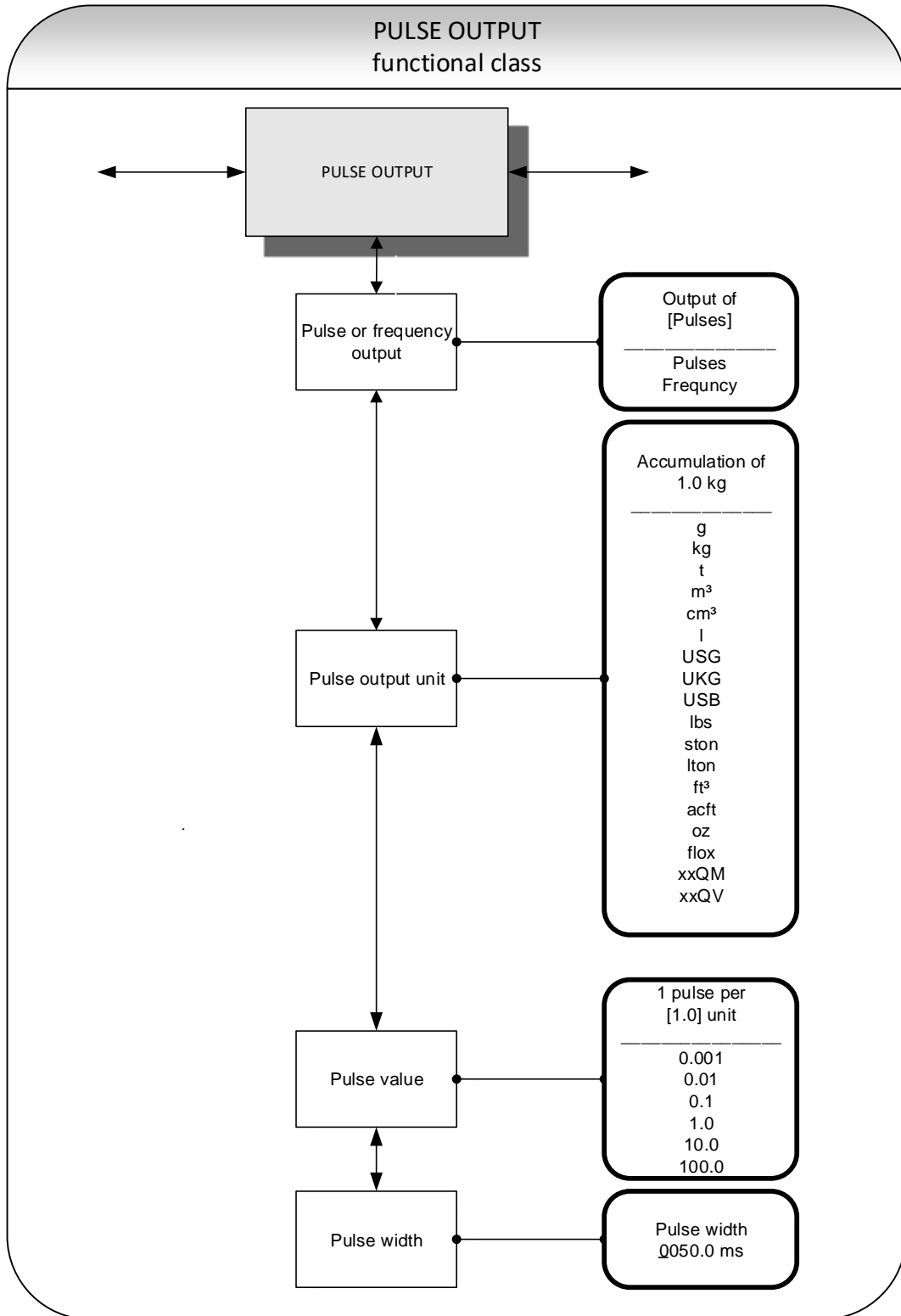

7.2.8.1 Pulse or frequency output

The *Pulse or frequency output* function allows the operator to define whether pulses per represent a unit of flow or a frequency between 0 and 1 kHz that represents an analogue output over the measuring range.

After selecting the frequency setting, the maximum frequency of 1 kHz will be generated when the upper-range value for mass or volume flow is reached (depending on the selected pulse unit). If the flow rate falls below the low flow volume, the actual frequency is 0 Hz.

After selecting the pulse setting, pulse value and unit the transmitter will determine the number of pulses per flow volume. When choosing a combination of these settings that cannot be fulfilled in real time for the upper-range value (e.g. the number of pulses per time unit cannot be generated due to the pulse width which is too large), the error message "Pulse width too large" or "Inconsistent parameter" will be displayed.

Press "Enter" to display the current setting:

Output of
[Pulses]

The current setting will be displayed and can be changed by toggling the arrow keys. Pressing the "Enter" key confirms the entry.

7.2.8.2 Pulse output unit

This function allows the operator to define the unit to be counted. After selecting the *Pulse output unit* function, press "Enter" to display the following selection field:

Accumulation of
1.0 kg

The current output unit will be displayed and can be changed by toggling the arrow keys. the operator can choose between the following units:

- Mass units:
 - g, kg, t, lbs, ston, lton, oz
- Volume units
 - m³, cm³, l, USG, UKG, USB, ft³, acft, floz
- progr. mass unit:
 - xxQM
- prog. volume unit
 - xxQV

Pressing the "Enter" key confirms the entry.

The valency of the programmable units are defined by the settings of the flow units described in sections 7.2.5.2, "Factor mass flow QM programmable unit" on page 62 and 7.2.5.8, "Factor volume flow QV programmable unit" on page 65.

7.2.8.3 Pulse value

This function allows the operator to define how many pulses will be output per unit counted. After selecting the *Pulse value* function, press "Enter" to display the current unit:

1 pulse per [1.0] unit

The current Pulse value will be displayed and can be changed by toggling the arrow keys. The operator can choose between the pulse values:

0.001, 0.01, 0.1, 1.0, 10.0, 100.0

Pressing the "Enter" key confirms the entry.

7.2.8.4 Pulse width

This function allows the operator to change the width of the output pulse to be output. If the pulse width is too large for the actual pulse number, it will be reduced automatically. In this case the warning "Pulse output saturated" will be displayed.

After selecting the Pulse width function, press "Enter" to display the following selection field:

Pulse width 0050.0 ms

The current pulse width will be displayed and can be changed by toggling the arrow keys. Pressing the "Enter" key confirms the entry.

The maximum output frequency can be calculated using the following formula:

$$f = \frac{1}{2 * pulse\ width[ms]} \leq _1000\ Hz$$

If connecting to electrical counter relays, we recommend pulse widths greater than 4 ms; for electromechanical counter relays the preset value should be 50 ms.

7.2.9 STATUS functional class

The functional class STATUS is comprised of the functions for setting the status output.

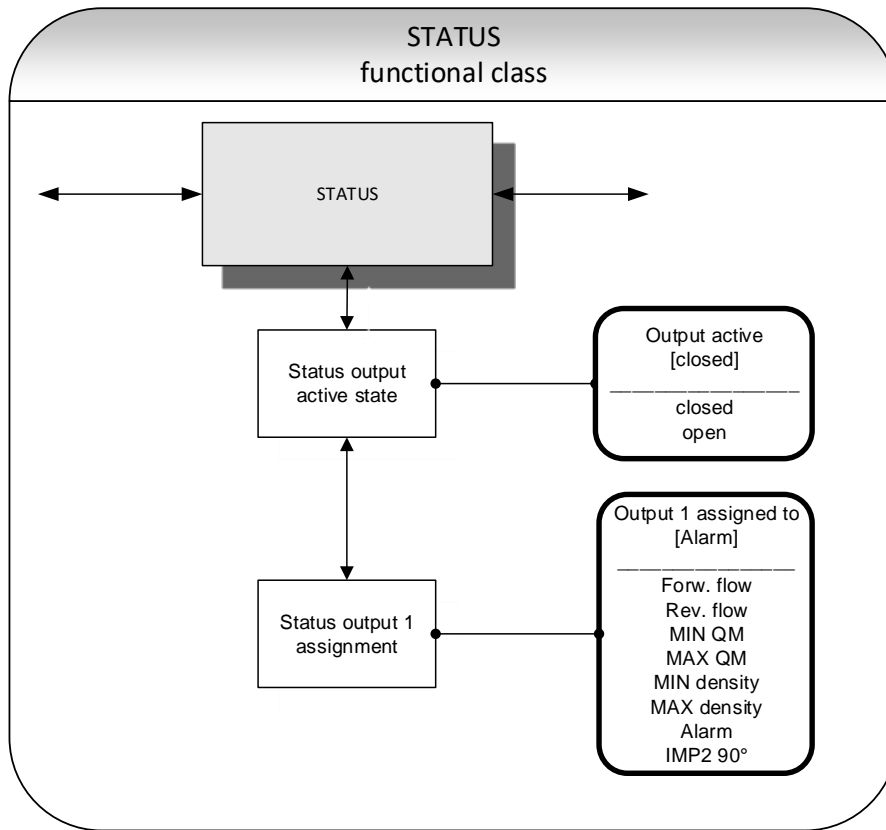

7.2.9.1 Status output active state

The status output can be compared to an electrical relay that can function as make or break contact. For safety-relevant applications, the operator will choose the break contact setting so that a power failure or failure of the electronics can be detected like an alarm. In standard applications, the output is used as make contact.

The *Status output state active state* function allows the operator to define the behaviour of the status output.

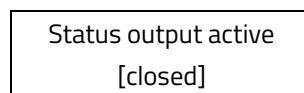

The current active state will be displayed and can be changed by toggling the arrow keys.

The operator can choose between the following settings:

- closed
- open

Pressing the "Enter" key confirms the entry.

7.2.9.2 Status output 1 assignment

This function allows the operator to define to which event the status output is to be assigned. The most general assignment is the alarm assignment because all set limiting values and the self-test function are then monitored via the status output.

After selecting the *Status output assignment* function, press "Enter" to display the current assignment.

Output 1 assigned to
[Alarm]

The current assignment will be displayed and can be changed by toggling the arrow keys. The operator can choose between the following settings:

- Flow direction recognition
 - Forward flow
 - Reverse flow
- Limiting values:
 - MIN QM
 - MAX QM
 - MIN density
 - MAX density
- All limiting values and error detection
 - Alarm
- Pulse output 2 for custody transfer operations
 - IMP2 90°,

Pressing the "Enter" key confirms the entry.

When selecting the IMP2 90° setting, a second pulse output will be realised via the status output that can be used for custody transfer operations.

7.2.9.3 Status output 2 assignment

Instead of current output 2 a second status output may be selected for custody transfer operations. It has the same assignment possibilities as status output 1. However, it cannot be used as a pulse output.

After selecting the Status output assignment function, press "Enter" to display the current assignment.

Output 2 assigned to
[not available]

The current assignment will be displayed and can be changed by toggling the arrow keys. The operator can choose between the following settings:

- Standard setting
 - Not available
- Flow direction recognition:
 - Forward flow
 - Reverse flow
- Limiting values
 - MIN QM
 - MAX QM
 - MIN density
 - MAX density
- All limiting values and error detection
 - Alarm

Pressing the "Enter" key confirms the entry.

7.2.10 CURRENT OUTPUTS functional class

The CURRENT OUTPUT functional class allows the operator to perform the settings for the current outputs of the transmitter.

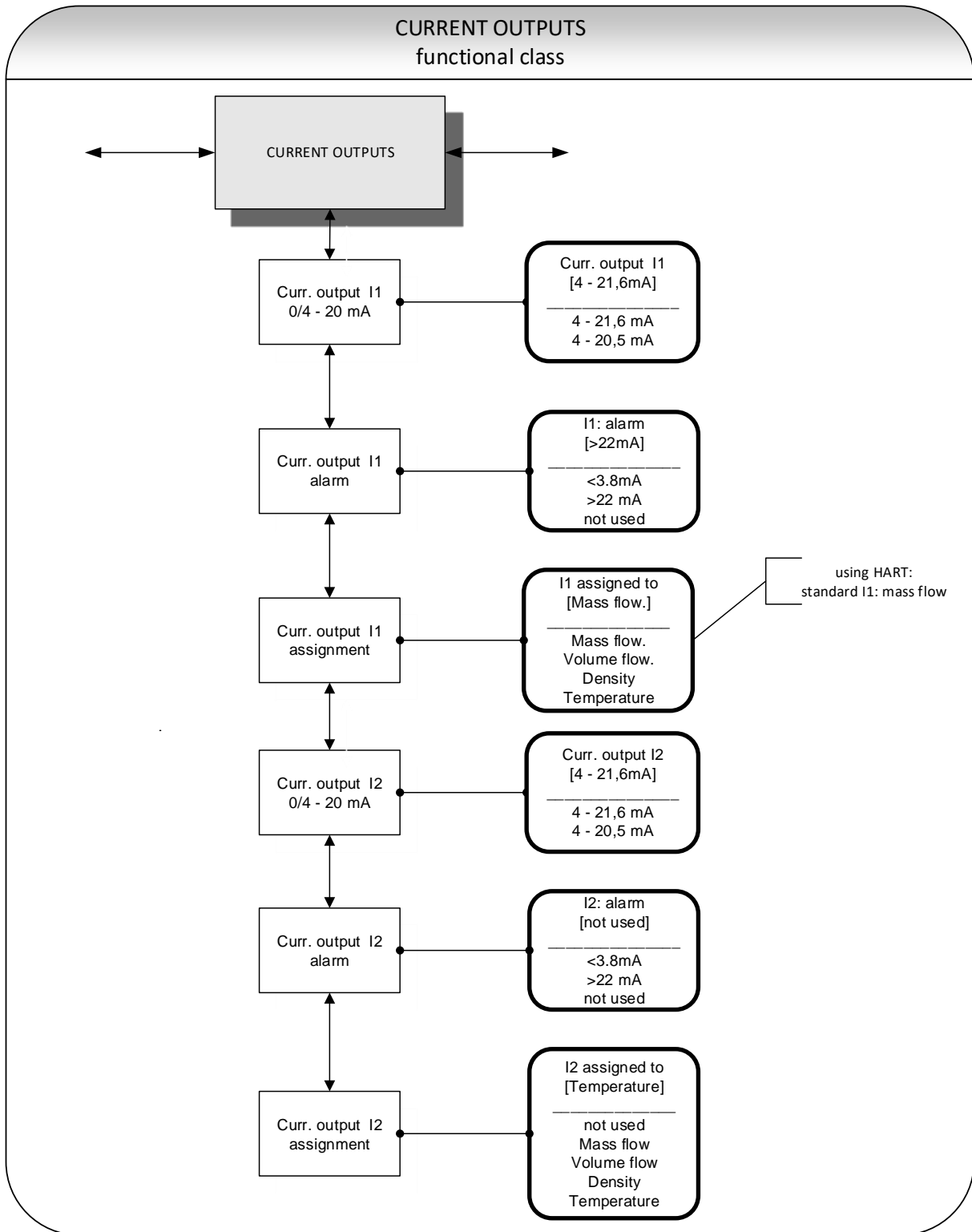

7.2.10.1 Current output I1 4 to 20 mA

The "Current output I1 4 to 20 mA" function allows the operator to define the range in which the current output is to be operated. Within the range from 4 to 21.6 mA (= 0 ... 110 %) HART® communication is not possible. The range from 4 to 20.5 mA follows the NAMUR recommendation and covers the range from 0 to 104 % of the measuring range. The standard range from 4 to 21.6 mA allows for a control of the measuring range of up to 110 %.

Press "Enter" to display the current setting.

Current output I1
[4] – 21.6 mA

The current assignment will be displayed and can be changed by toggling the arrow keys.

The operator can choose between the settings:

- 4 – 20.5 mA
- 4 – 21.6 mA

Pressing the "Enter" key confirms the entry.

The following diagram displays the impacts of the selected setting

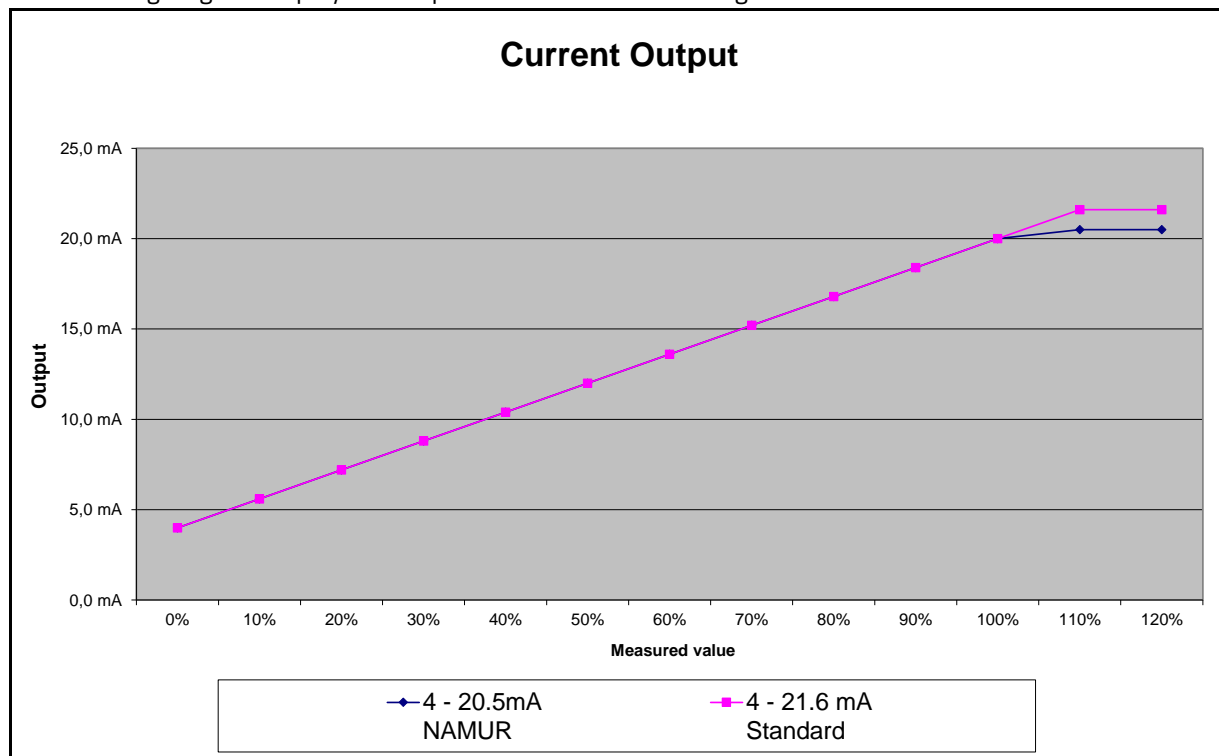

Figure 2: Current Output as NAMUR or Standard

7.2.10.2 Current output I1 alarm

This function allows the operator to define the state taken on by the current output when a state of alarm is detected. This information can be analysed in the control system. Press "Enter" to display the current setting:

I1 : alarm
[>22mA]

The current assignment will be displayed and can be changed by toggling the arrow keys. The operator can choose between the following settings:

- not used no alarm function
- > 22 mA current rise in the case of an alarm
- < 3.8 mA current reduction in the case of an alarm

Pressing the "Enter" key confirms the entry

7.2.10.3 Current output I1 assignment

This function allows the operator to define the measured value to be output as an analogue signal via current output I1. When devices with HART® communication capabilities are used, current output I1 is usually assigned to mass flow. Press "Enter" to display the current setting.

I1 assigned to
[Mass flow]

The current assignment will be displayed and can be changed by toggling the arrow keys. The operator can choose between the following settings:

- Mass flow
- Volume flow
- Density
- Temperature

Pressing the "Enter" key confirms the entry

7.2.10.4 Current output I2 4 to 20 mA

The "Current output I2 4 to 20 mA" function allows the operator to define the range in which the current output is to be operated. The range of 4 to 20.5 mA follows the NAMUR recommendation and covers the range from 0 to 104 % of the measuring range. The standard range of 4 to 21.6 mA allows for a control of the measuring range of up to 110 %.

Press "Enter" to display the current setting.

Current output I2
[4] – 21.6 mA

The current assignment will be displayed and can be changed by toggling the arrow keys. The operator can choose between the following settings:

- 4 – 20.5 mA
- 4 – 21.6 mA

Pressing the "Enter" key confirms the entry

7.2.10.5 Current output I2 alarm

This function allows the operator to define the state taken on by the current output when a state of alarm is detected. This information can be analysed in the control system. Press "Enter" to display the current setting.

I2 : alarm
[not used]

The current assignment will be displayed and can be changed by toggling the arrow keys. The operator can choose between the following settings:

- not used no alarm function
- > 22 mA current rise in the case of an alarm
- < 3.8 mA current reduction in the case of an alarm

Pressing the "Enter" key confirms the entry.

7.2.10.6 Current output I2 assignment

This function allows the operator to define the measured value to be output as an analogue signal via current output I2. Press "Enter" to display the current setting.

I2 assigned to
[Temperature]

The current assignment will be displayed and can be changed by toggling the arrow keys.
The operator can choose between the following settings:

- Mass flow
- Volume flow
- Density
- Temperature
- not available (in this case the vendor setting must not be changed)

Pressing the "Enter" key confirms the entry.

7.2.11 SIMULATION functional class

The functional class SIMULATION is comprised of the functions for simulating the outputs. If simulation is activated, all output signals will be generated based on the selected type of simulation. The peripherals connected to the device can be tested without a flowing product.

Simulation will be deactivated automatically if the operator switched the device off or did not touch any control unit keys for about 10 minutes. Simulation can also be activated and controlled via HART® commands.

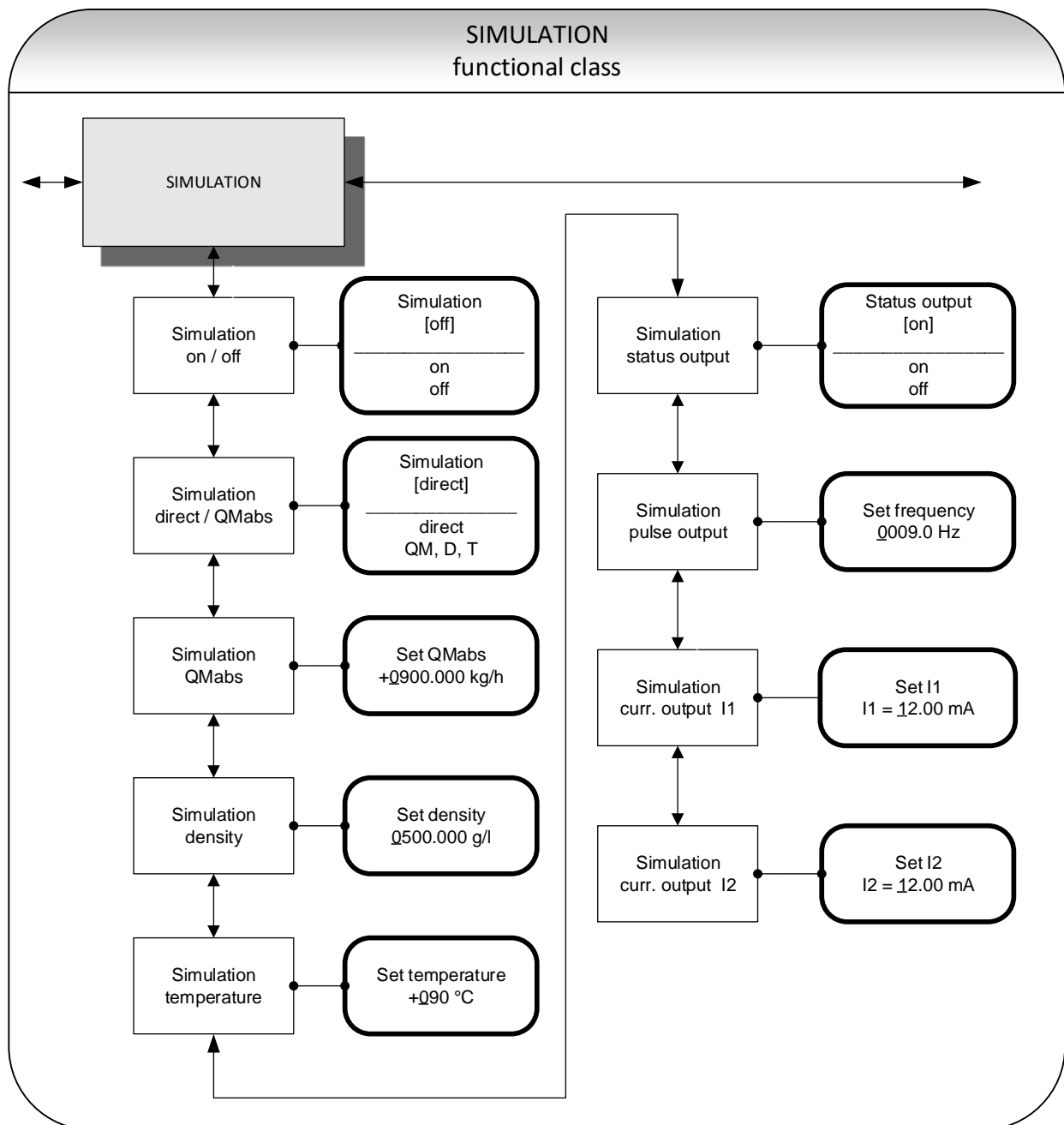

7.2.11.1 Simulation on/off

The *Simulation on/off* function allows the operator to activate or deactivate simulation. If simulation is activated, all output signals will be generated based on the selected type of simulation. The peripherals connected to the device can be tested without a flowing product. Press "Enter" to display the current status.

Simulation
[off]

The current setting will be displayed and can be changed by toggling the arrow keys.

The operator toggle between "on" and "off."

Pressing the "Enter" key confirms the entry.



Note:

Simulation will be deactivated automatically if the operator switches the device off or does not touch any control unit keys for approximately 10 minutes.

7.2.11.2 Direct simulation

This function allows the operator to define whether simulation is comprised of the measurement of the three physical values mass flow, density and temperature or whether the outputs will be set directly. Press "Enter" to display the selected type of simulation.

Simulation
[direct]

The current setting will be displayed and can be changed by toggling the arrow keys.

The operator can choose between the following settings:

- Direct pulse and current outputs are programmed directly
- QM, D, T a measurement is simulated

Pressing the "Enter" key confirms the entry.

If "direct" simulation is activated, any output will perform based on the settings described in Section 7.2.11.4, "Direct simulation of outputs". It is therefore recommended that the settings be defined before starting simulation. They can then be purposefully changed during simulation.

The status of the outputs during measured value simulation based on the setting "QM, D, T" depends on the selected simulation values of these three variables, the measuring range settings and the assignment of the outputs. If, for example, the pulse output is assigned to volume measurement, it will be affected by all three simulation values at the same time [$V \approx QM(T) / D(T)$].

7.2.11.3 Measured value simulation

If the operator selected the setting "QM, D, T" described in Section 7.2.11.2 on page 88, the following three possible settings will affect the output behaviour during measured value simulation, where all measured values are simulated at the same time.

7.2.11.3.1 Simulation mass flow QM abs

In order to simulate mass flow, the operator can define a "measured value." The flow rates will be simulated in both directions. All outputs will perform based on the simulated measured value.

Set QM abs ±0900.0 kg/h

The current value will be displayed and can be changed by toggling the arrow keys. Pressing the "Enter" key confirms the entry.

7.2.11.3.2 Density simulation

In order to simulate density/volume measurement, the operator can define a "density measured value." If volume measurement is assigned to an output, it will change depending on mass flow and density simulation. All outputs will perform based on the simulated measured value.

Set density 0500.0 g/l

The current value will be displayed and can be changed by toggling the arrow keys. Pressing the "Enter" key confirms the entry.

7.2.11.3.3 Temperature measurement simulation

In order to simulate a temperature, the operator can define a "measured value." All outputs will perform based on the simulated measured value.

Set temperature +090 °C

The current value will be displayed and can be changed by toggling the arrow keys. Pressing the "Enter" key confirms the entry.

7.2.11.4 Direct simulation of outputs

If the operator selected the setting "Direct simulation" described in Section 7.2.11.2, "Direct simulation" on page 88, the following four possible settings will affect the output behaviour during measured value simulation, where all measured values are simulated at the same time.

7.2.11.4.1 Status output simulation

The *Status output simulation* function allows the operator to purposefully activate the status output. Press "Enter" to display the current state.

Status output
[off]

The current setting will be displayed and can be changed by toggling the arrow keys

The operator can toggle between "on" and "off".

Pressing the "Enter" key confirms the entry.

7.2.11.4.2 Pulse output simulation

The *Pulse output simulation* function allows the operator to define a frequency to be assigned to the pulse output. After selecting this function and pressing "Enter", the following selection field will be displayed:

Set frequency
0210.0 Hz

The current value will be displayed and can be changed by toggling the arrow keys

The frequency range of the pulse output can be set from 6 Hz to 1100 Hz.

Pressing the "Enter" key confirms the entry.

7.2.11.4.3 Simulation current output I1

This function allows the operator to define a current for current interface 1. Press "Enter" to display the set current.

Set I1
I1 = 10.50 mA

The current value will be displayed and can be changed by toggling the arrow keys.

Values in the range from 3.8 mA to 22.6 mA are permitted.

Pressing the "Enter" key confirms the entry.

7.2.11.4.4 Simulation current output I2

As described in Section 7.2.11.4.3, current output 2 can also be configured.

7.2.12 SELF-TEST functional class

The SELF-TEST function class is comprised of the functions relating to the self-test of the sensor. The diagnostic functions of the transmitter, which monitor the proper functioning of the electronics and the software, are always active and cannot be switched off. The excitation current can be monitored in addition.

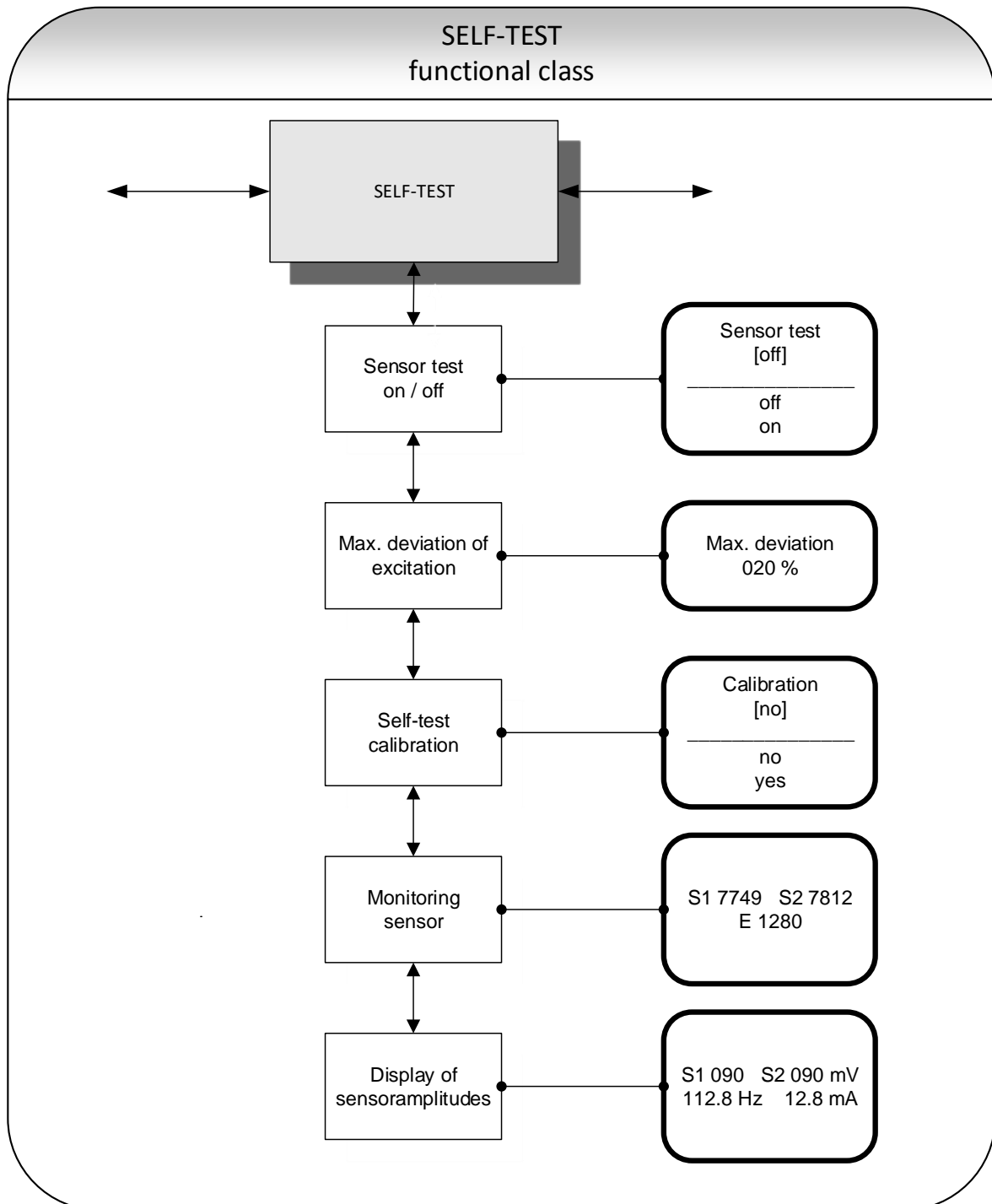

The excitation current of each sensor in the system individually depends on the sensor itself, the fluid and the installation conditions. If the excitation currents changes while the fluid remains the same, conclusions may be drawn for e.g. potential wear and tear, viscosity changes or air bubbles. The operator has the possibility of defining a "normal state" ("Self-test calibration") and setting the limit for a permissible deviation. This function is deactivated in the device when delivered.

7.2.12.1 Sensor test on/off

The *Sensor test on/off* function allows the operator to activate or deactivate the monitoring function of the excitation current.

Sensor test [off]

The current setting is displayed and can be changed by toggling the arrow keys. The operator can toggle between "on" and "off." The standard factory setting is "off." Pressing the "Enter" key confirms the entry.

7.2.12.2 Max. deviation of excitation

This function allows the operator to define a limiting value in the form of a percentage deviation from the normal value. The excitation current is electronically limited to 50 mA (display value 500) and may take on larger values for only a limited period of time (transient reactions).

Max. deviation 020 %

The current value will be displayed and can be changed by toggling the arrow keys. When changing the max. deviation value, permissible fluctuations shall be considered. Pressing the "Enter" key confirms the entry.

7.2.12.3 Self-test calibration

The magnitude of the excitation current not only depend on the sensor itself but also on the installation conditions and the viscosity and density of the fluid. Therefore, the "normal" value can only be determined at the installation site during operation using the Self-test calibration function.

Calibration [no]

The current setting is displayed and can be changed by toggling the arrow keys. When set to [yes], the "normal" value is automatically calculated. No additional information is required for this function. Pressing the "Enter" key confirms the entry.

7.2.12.4 Monitoring of sensor amplitude and excitation current

The first line of this window contains the amplitudes of the sensor signals S1 and S2 in 10 μ V. Both values should be close to each other or identical (ideal case). The second line shows the excitation current in 10 μ A units.

S1 7749 S2 7812
E 1280

Example: The sensors have amplitudes of 77.49 mV and 78.12 mV. The excitation current is 12.8 mA. These values are used as reference values for the self-test function. They are measured by using the function 7.2.12.3, "Self-test calibration" on page 92. Afterwards they can be displayed or edited by this function.

7.2.12.5 Display of sensor amplitudes

The first line of this window contains the actual measured amplitudes of the sensor signals S1 and S2. Both values should be close to each other or identical (ideal case). The second line shows the excitation frequency and current.

S1 090 S2 089 mV
112.8 Hz 12.8 mA

Example: The sensors have amplitudes of 90 mV and 89 mV. The excitation current is 12.8 mA and the actual resonance frequency is 112.8 Hz.

The combination with the raw value display (see chapter 7.2.1.14, "Raw values" on page 52) supports the analysis of all electrical signals between mass flow sensor and transmitter.

7.2.13 UMC4 TRANSMITTER SETTINGS functional class

This functional class is comprised of the general settings (e.g. language) affecting the behaviour of the transmitter.

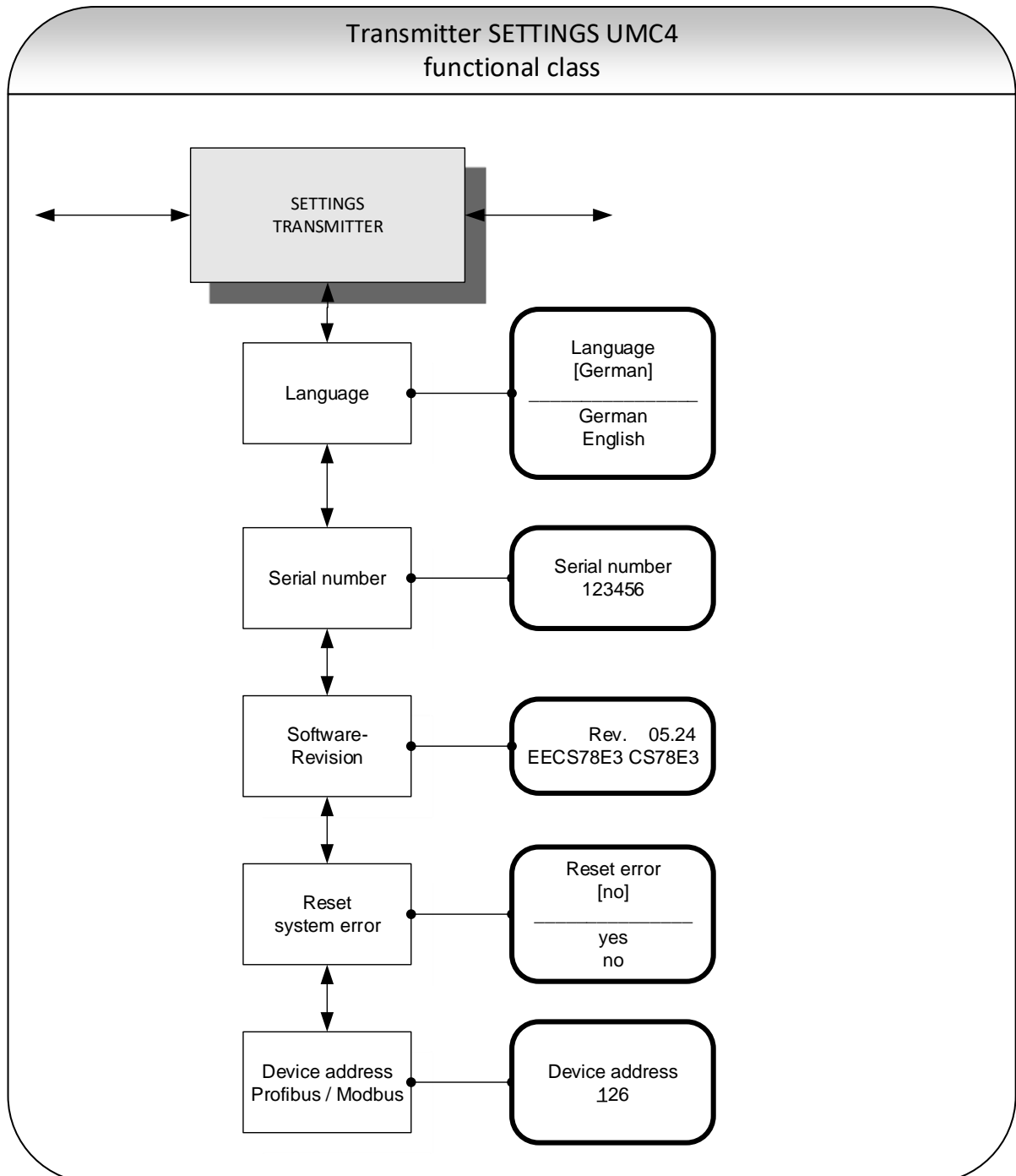

7.2.13.1 Language

Two languages are presently available in the control unit BE4: German and English.

Language [English]

The current value will be displayed and can be changed by toggling the arrow keys.

Other languages such as Russian, French, Italian or Spanish will be available in a special version of the BE4 control unit

Pressing the "Enter" key confirms the entry.

7.2.13.2 Serial number

With the help of the *Serial number* function, the transmitter is assigned to an order. This number provides access to internal vendor data if the device needs servicing. The serial number is printed on the rating plate of the transmitter. After selecting this function, press "Enter" to display the following information field:

Serial number: 123456

To ensure that the sensor, the transmitter and the documents created within quality management are assigned correctly, this entry may not be changed.

7.2.13.3 Software version

When the function *Software version* is selected, the software version of the transmitter software is displayed.

Rev. 05.24 EECSA3C9 CSA3C9

The second line contains the hexadecimal checksum that was calculated via the program storage created during program development and the microcontroller checksum of the same storage. Both checksums must be identical, should the program storage not been damaged.

7.2.13.4 Reset system error

The integrated diagnostic system of the UMC4 transmitter distinguishes between two types of errors (see also Section 8.2, "UMC4 transmitter error messages"). Self-test errors such as problems with a sensor line or inconsistent parameter inputs are displayed as textual error messages. Once the error has been eliminated, the message automatically disappears from the display. For further information, see Section 8.2.3.1, "Display of self-test errors".

Errors that are attributable to system memory or software, division by zero, or a fault in the electronics unit are designated as system errors. These error messages are not reset automatically after the error (usually of very brief duration) is eliminated. **Before resetting a system error manually, we advise you to contact our technical service department.** For further information, see Section 8.2.3.1, "Display of self-test errors".

Reset error [no]

The setting "no" will be displayed and can be changed by toggling the arrow keys.

If the operator toggles to [yes] and confirms the action by pressing "Enter", the error messages disappear from the display. If the message reappears shortly after, contact our technical service department for help.

7.2.13.5 Profibus/Modbus device address

Note: *This setting is reserved for future communication developments and is at present unused.*

Before connecting fieldbus devices to a bus system, the operator must define a device address. This address is a unique assignment to a participant device in a bus system (similar to a street number).

After selecting the *Profibus/Modbus device address*, press "Enter" to display the set address:

Device address 126

The current Address will be displayed and can be changed by toggling the arrow keys.

Pressing the "Enter" key confirms the entry.

7.2.14 SENSOR SETTINGS functional class

The SENSOR SETTINGS functional class is comprised of the settings regarding the mass flow sensor.

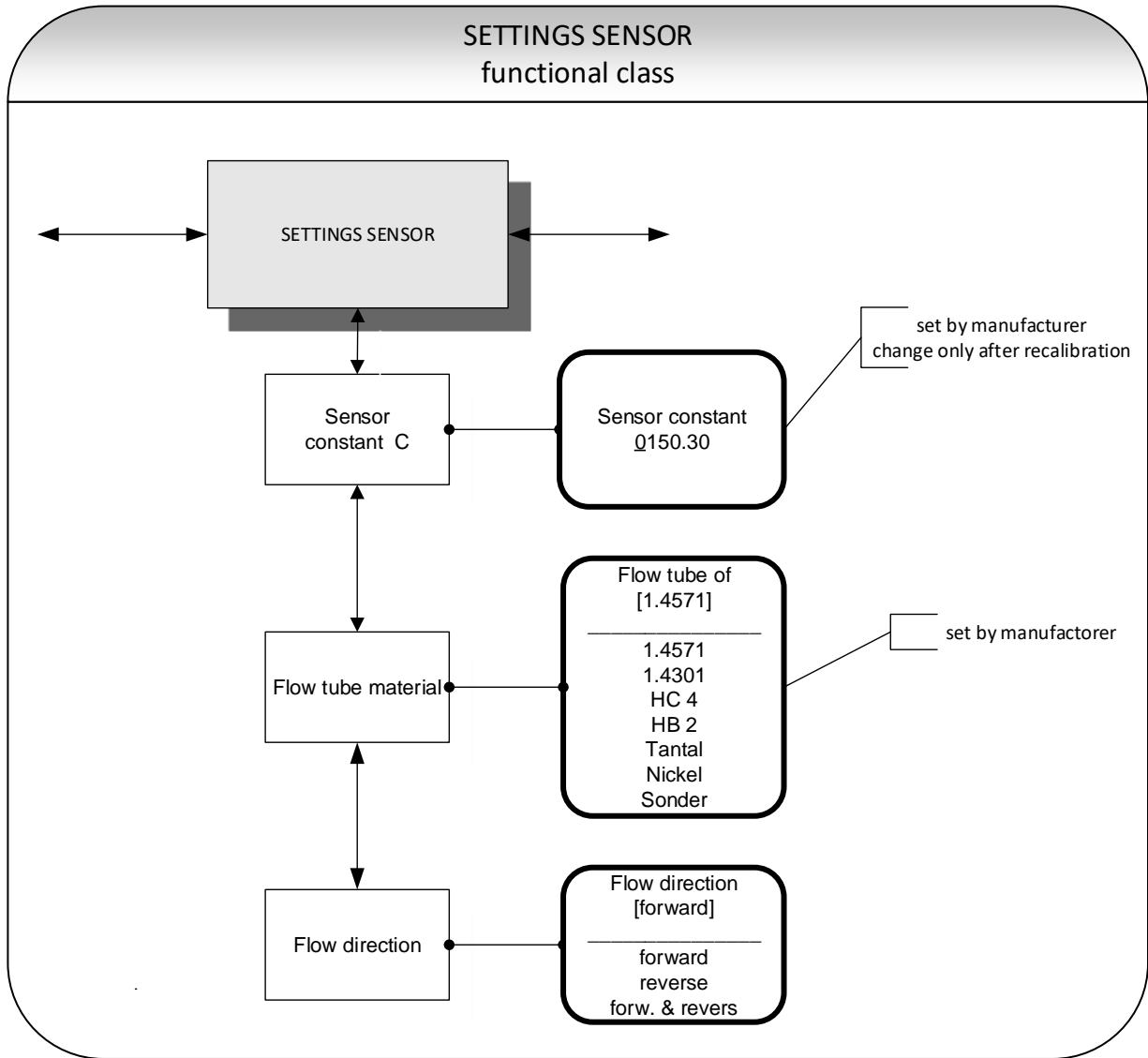

7.2.14.1 Sensor constant C

Sensor constant C is the sensor calibration value for mass flow. This constant is defined when the flowmeter is calibrated at the factory and can be found on the rating plate.

Sensor constant
+0150.00 kg/h



Caution:

Changing the sensor constant C to a value that differs from the value on the rating plate of the sensor will result in incorrect mass-flow measurements.

Normally, the sensor constant is changed only when the device is calibrated, e.g. for a validation measurement for a custody transfer operation.



Note:

The sensor constant must always be preceded by a plus or minus sign. The delivery default setting is a plus sign. If inlet and outlet section are interchanged when the device is installed (the flow direction is indicated by an arrow on the sensor), the transmitter will display a "forward flow" negative measurement value. If the (plus or minus) sign of the sensor constant is then changed without changing the actual value, a plus sign will again be displayed. No changes need be made in the disposition of the electrical connections (wires).

7.2.14.2 Sensor material

The *Sensor material* function allows the flow tube material code to be entered. This material code can be found on the sensor rating plate. This setting is defined by the vendor when the device is first put into operation at the factory.

Flow tube material
[1.4571]

The information in this field is purely of informative nature.

7.2.14.3 Flow direction

This function allows the operator to define the flow direction that the transmitter will evaluate. Only “forward” should be selected so as to prevent reverse flow from being measured. The standard factory setting is “forward & reverse.” After selecting the *Flow direction* function, press “Enter” to display the current setting.

Flow direction
[forward]

The current direction will be displayed and can be changed by toggling the arrow keys. the operator can choose between:

- forward
- reverse
- forward & reverse

Pressing the “Enter” key confirms the entry.

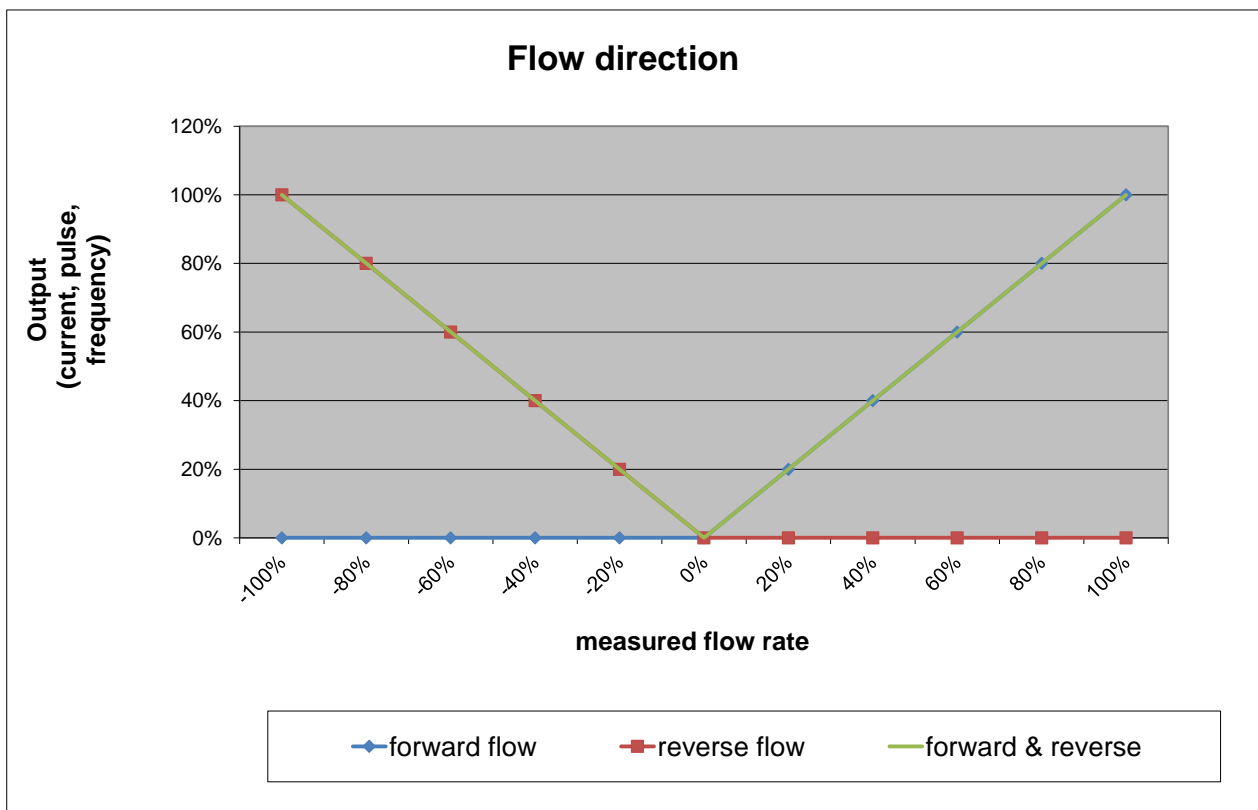
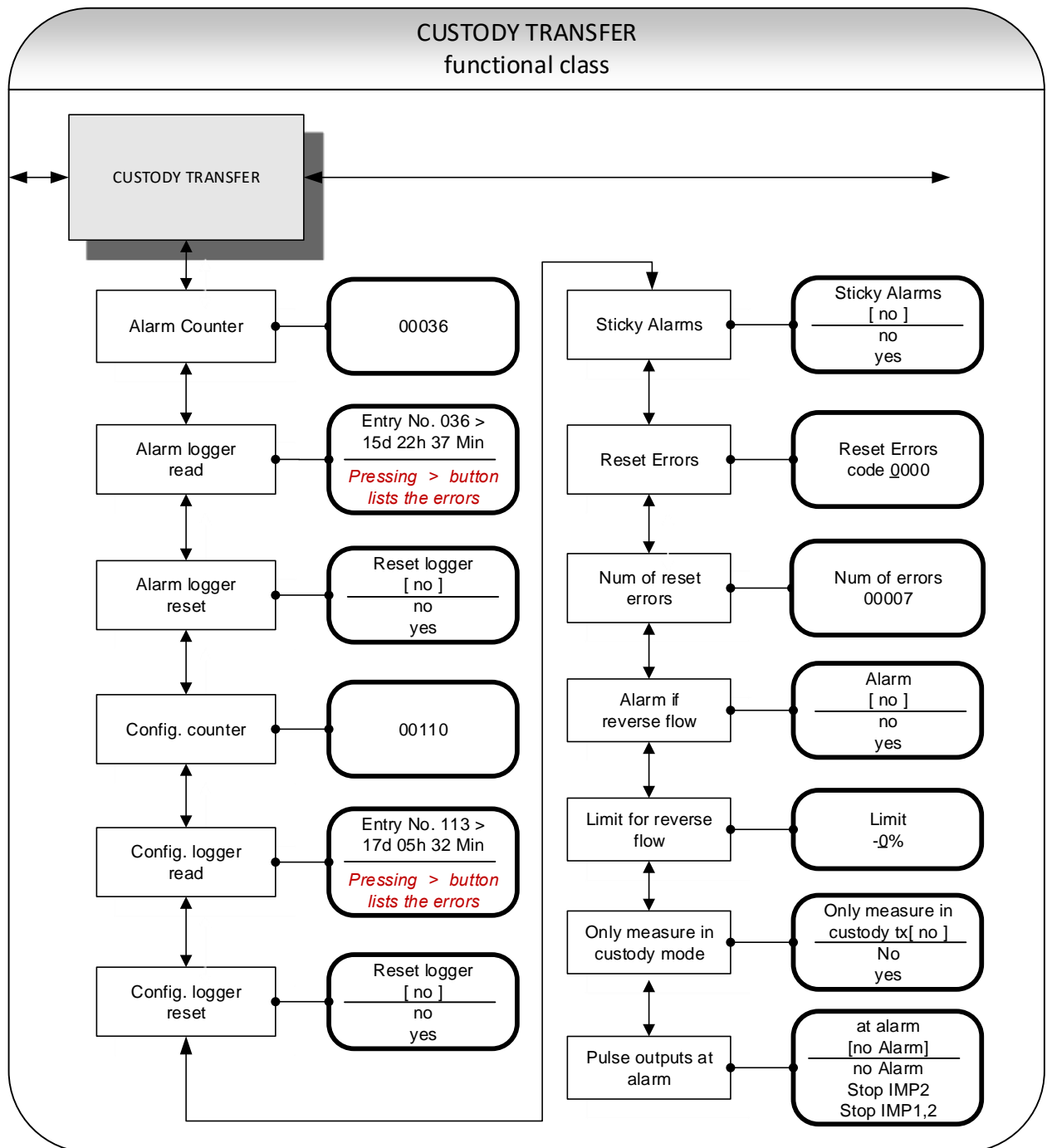

Figure 3: Influence of the Flow Direction Setting

7.2.15 CUSTODY TRANSFER functional class

The custody transfer functional class comprises of all parameters of the UMC4's user interface required to configure the custody transfer mode. Furthermore, the Alarm-Logger and Configuration Audit Logger are also situated in this menu where each alarm can be individually viewed. The Configuration Audit Logger records the last 20 parameter amendments or events such as the opening of the custody stamp switch or a renewed setting of the zero-point.



7.2.15.1 Alarm counter

The Alarm counter counts each time an alarm occurs or an alarm disappears. It is also incremented each time the device is powered up. The Alarm counter is stored in the EEPROM and can be displayed by pressing the "Enter" key.

Alarm counter 00035

7.2.15.2 Alarm Logger read

The Alarm Logger stores the most recent 30 changes of the device status (alarm occurring, alarm disappearing). The Alarm Logger is stored in the EEPROM. The entries of the logger can be read by pressing the "Enter" key.

Entry No. 036 > 15d 22h 37 Min

By using the ◀ or ▶ cursor keys it is possible to navigate through all saved entries.

7.2.15.3 Alarm Logger reset

The Alarm Logger can be reset. To enable a reset to be performed, the customer password must first be entered (See 7.2.2.1, "Customer password" on page 53).

Reset [no]

7.2.15.4 Config. counter

The Configuration Audit counter counts each time a parameter is amended. It counts if the custody stamp is set or opened. The Configuration Audit counter is stored in the EEPROM and can be displayed by pressing the "Enter" key.

Config. counter 00035

7.2.15.5 Config. logger read

The Configuration Audit Logger stores the most recent 20 amendments made to parameters or the execution of e.g. zero point calibration. The Configuration Audit Logger is stored in the EEPROM.

The entries of the logger can be read by pressing the "Enter" key.

Entry No. 105 > 09d 42h 12 Min

By using the ◀ or ▶ cursor keys it is possible to navigate through all saved entries.

7.2.15.6 Config logger reset

The Configuration Audit Logger can be reset. To enable a reset to be performed, the customer password must first be entered. (See 7.2.2.1, "Customer password" on page 53).

Reset [no]

7.2.15.7 Sticky alarms

In some applications it may be a requirement to keep an alarm message displayed even after the alarm itself has disappeared („sticky"). Sticky alarm messages need to be acknowledged by means of customer access. With the "Sticky Alarm" parameter, this kind of behaviour can be activated or deactivated. When deactivated [off], the alarm message is removed from the display once the reason for the alarm has ceased to exist. However, the Alarm Logger stores the occurrence of the alarm and the alarm counter is incremented. The default value for "sticky alarm" is [no]

Sticky Alarms [no]

7.2.15.8 Reset errors

When Sticky Alarms are activated, the alarm messages requires customer access (Password: 5773) for them to be removed. To reset the messages a predefined code must be entered and validated. This function is also available in custody transfer mode without having to open the custody stamp. The error counter is incremented each time the function is performed. This counter is stored in EEPROM. The Alarm Logger as well as the Configuration Audit Logger recognise the execution of this function.

This function can also be accessed via the "PASSWORD" menu. (Password: 5773)
(See 7.2.2.1, "Customer password" on page 53).

Reset Errors Code 0000

7.2.15.9 Num of reset errors

Displays the error reset counter, which is incremented each time an alarm message is reset by customer access (see above).

Num of errors 00007

7.2.15.10 Alarm if reverse flow

In some applications, it may be required to receive an alarm if there is reverse flow. With this parameter, the Alarm can be activated or deactivated. If activated [yes] a reverse flow below the set value "limit for reverse flow" (see 7.2.15.11, "Limit for reverse flow") will result in an alarm.

The default value for "alarm if reverse flow" is [no].

Alarm [no]

7.2.15.11 Limit for reverse flow

An alarm is generated if the "Alarm if reverse flow" is activated and a reverse flow more negative than this parameter is present. This parameter is given in % of URV.

The default value for "limit for reverse flow" is [-0%]

Limit -0%

7.2.15.12 Only measure in custody mode

If this parameter is set to "yes" an alarm is activated when the custody stamp is opened.

The default value for "only measure in custody mode" is [yes]

Only measure in custody tx [yes]

7.2.15.13 Pulse outputs at alarm

This parameter selects the behaviour of the pulse outputs in the event of an alarm during a flow delivery. The following choices are available for selection:

- No Alarm - Both outputs continue pulsing
- Stop IMP2 - Pulse 2 is stopped. Pulse output 2 is disabled while pulse output 1 continues delivering pulses.
- Stop IMP1,2 - Both outputs are stopped, no pulses are delivered.

The default value for "pulse outputs at alarm" is [Stop IMP2]

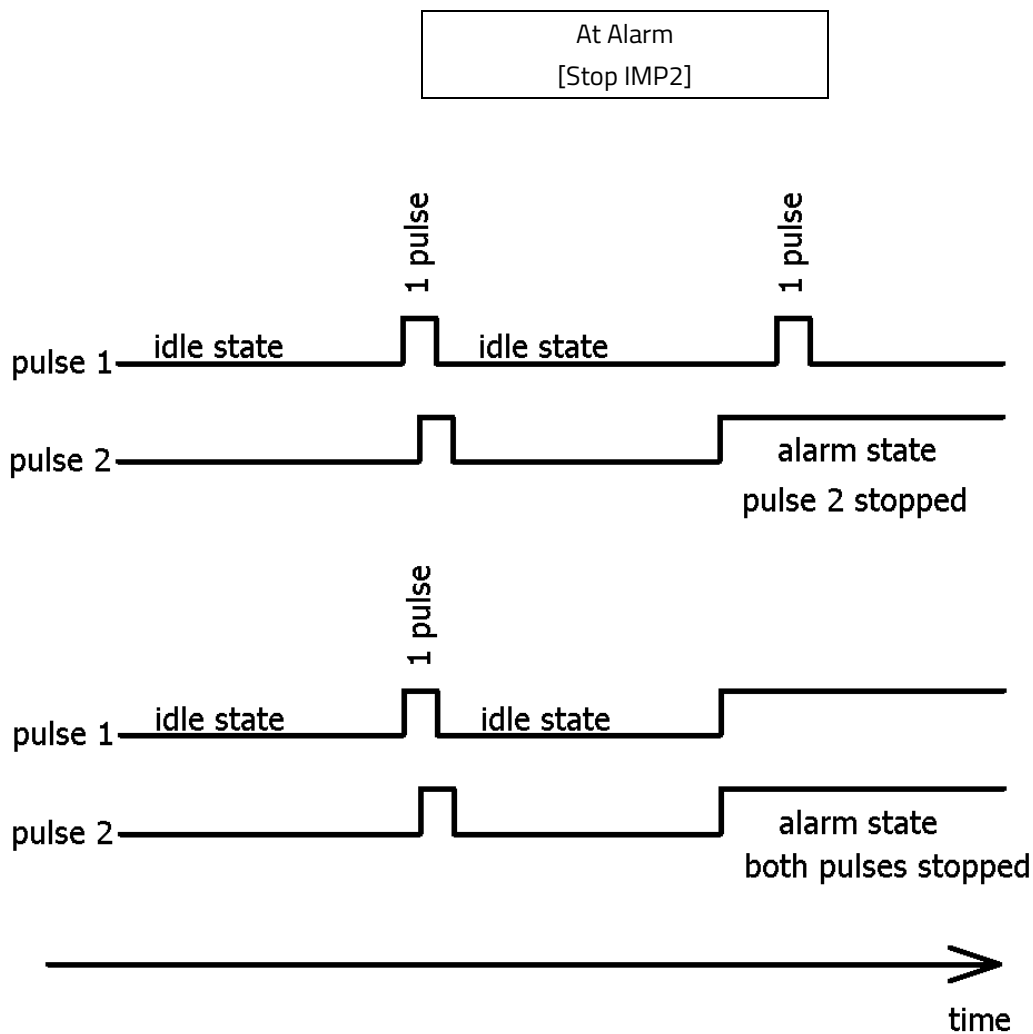
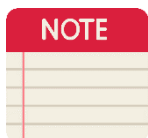

Figure 4: Pulse behaviour in the event of an alarm

Figure 4 depicts the behaviour of the two pulse outputs in the event of an alarm during a flow delivery

7.3 Density calibration

For continuous processes, where only small variations of temperature are experienced and where only liquid medias of similar density are used, the user can perform a density calibration locally by at the place of installation.

**Note:**

Density measurement is not available for all sensor types.

Before proceeding with the density calibration described in this chapter ensure that, your sensor is capable of density measurement.

7.3.1 Conditions

For a local density calibration the following conditions must be fulfilled:

- The sensor must be suitable for a density measurement. Contact our service department to check the suitability of your sensor for a density calibration. For all suitable sensors, the Heinrichs offers a 3-point calibration with an accuracy of at least 5 g/l. Sensors, for which the manufacturer calibration is not available, are not suitable for local single point calibrations.
- For the local calibration the medium's density must be known or be determined by a suitable procedure using exactly the same process temperature present in the sensor during measurement.
- The medium must be liquid. For gaseous media the density calibration is not suitable.

7.3.2 Procedure

The density calibration procedure is as follows:

- The transmitter is powered up and the sensor is filled with the medium under operating conditions.
- A waiting period of at least 15 minutes is to be given, to allow the sensor including its enclosure and flanges can adopt the operating temperature.
- After the input of the customer's password select functional class DENSITY and "density calibration hot medium" (See chapter 7.2.6.15, on page 72).
- Independent of the type of liquid medium and its temperature the beginning of the calibration is confirmed by selecting "yes". Thereupon the transmitter captures the medium temperature and current resonant frequency of the sensor.
- Subsequently the function "measured values hot medium" must be selected, the displayed measured values of temperature and frequency are confirmed by pressing the Enter-key two times. In the next field the density of the medium must be entered in unit of g/l or kg/m³. (See also chapter 7.2.6.16 on page 72.)
- Subsequently, the function "finish density calibration" is used to finish density calibration. (See also chapter 7.2.6.17 on page 72.)
- Finally the function "density measurement on/off" activates the density measurement. (See also chapter 7.2.6.1 on page 67.)
- Now the measured density and also volume flows can be indicated or assigned to one of the outputs e.g. current output 2.

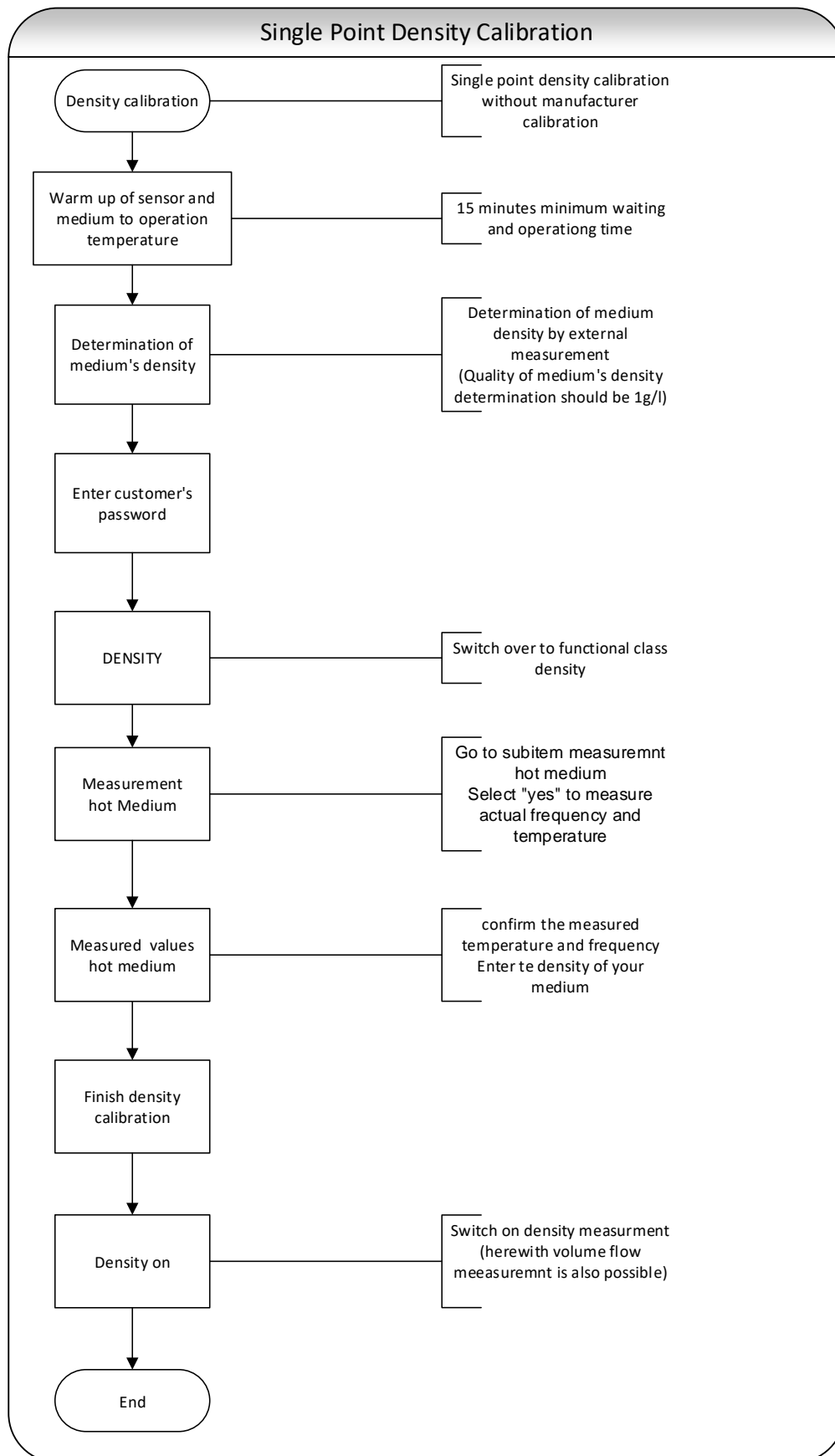

8. Trouble shooting

Should you experience problems with your flow meter after the meter has been installed and commissioned, go through the following checklist of regularly encountered errors before contacting our service department.

8.1 Self-help Checklist

Observation	Possible causes and remedy
The display is blank and there are no output signals	<ul style="list-style-type: none"> The supply voltage cables are not properly connected. Check! The transmitters fuse has blown. For position and approved replacement types refer to section 5.1 on page 35. Measuring electronics are defect. Contact HM service
The display is blank but the output signals are delivering signals	<ul style="list-style-type: none"> The BE4 display unit has been rotated and was incorrectly seated back onto its connector. Remove the BE4 unit and replace it carefully onto its connector. The BE4 Unit is defect. Contact service
The display contains undefinable characters	<ul style="list-style-type: none"> A foreign language is set. Refer to section 7.2.13.1 on page 95 to change the language The communication to the display has been disrupted. Restart the transmitter by removing its power. If the problem persists, contact our service department.
A measured value is displayed but is not being updated on a regular basis	<ul style="list-style-type: none"> The Ambient temperature is below $-25\text{ }^{\circ}\text{C}$ The function of the LCD display cannot be guaranteed below $-25\text{ }^{\circ}\text{C}$, but will return to full function once the ambient temperature rises.
An error message is displayed	<ul style="list-style-type: none"> Delete the error as described in section 7.2.13.4 and restart the transmitter. If the error persists, note the error code and refer to section 8.2.3 for an error description. If the error could not be rectified in this way, contact our service department for further assistance

Table 12: Self-help Checklist

8.2 UMC4 transmitter error messages

The integrated UMC4 transmitter distinguishes between two types of errors. Self-test errors such as problems with a sensor line or inconsistent parameter inputs are displayed as text error messages. Once the error has been eliminated, the message automatically disappears from the display. For further information, see Section 8.2.3.1, "Display of self-test errors".

Errors that are attributable to system memory or software, division by zero, or a fault in the electronics unit are designated as system errors. These error messages are not reset automatically after the error (usually of very brief duration) is eliminated. **Before resetting a system error manually, we advise that you contact our technical service department.** For further information, see Section 8.2.3.2, "Display of system error".

If the cause of any of the error messages described below cannot be eliminated, contact the device vendor.

8.2.1 Standard operating mode

The transmitter operates as described above. After the cause of the error message has been eliminated, the message automatically disappears. The self-test for monitoring the excitation current can be activated or deactivated via the "Sensor test" function.

8.2.2 Custody transfer mode

When the device is placed in Custody transfer mode, any errors will remain on the display until the error itself has disappeared or until the error is acknowledged via the "Enter" button.

All error occurrences and parameters amended whilst in Custody Transfer Mode are logged in an Audit log file, which can be requested via HART®.

8.2.3 List of error messages

8.2.3.1 Display of self-test errors

Self-test errors are displayed as plain text in the set language (German or English) on the second line of the LCD.

Display (English)	Description	Possible cause of error and remedy
empty pipe	Empty-pipe detection has been activated. The density of the medium is less than the set limit for the empty pipe detection, pipe is empty.	Product contains air bubbles/pipe is empty. Bubble-free filling must be ensured.
Partially filled?	The exciter cannot stimulate the pipes sufficiently to achieve the necessary vibration amplitude	This error can be caused through air / gas bubbles in the pipes or through a partial filling.
Power fail?	Detects a power disruption in custody transfer applications during a mass-flow of $Q > 0.5\%$ from the measurement range end-value. By no-flow conditions, the power can be disconnected without error. Only valid when "Sticky Alarms" are activated	Check power supply
malfunction T	Wire breakage / short circuit in the temperature measurement circuit	Check the lines between temperature sensor and transmitter. Measure resistance of PT1000
malfunction S1	Wire breakage / short circuit of the sensor coil 1 connection.	Check the lines between sensor coil and transmitter. Measure coil resistance.
malfunction S2	Wire breakage / short circuit of the sensor coil 2 connection.	Check the lines between sensor coil and transmitter. Measure coil resistance.

Display (English)	Description	Possible cause of error and remedy
Does not vibrate exc. too large	The measuring tubes are not vibrating A excitation current exceeding the limit will be detected.	Possible causes: Non-symmetrical filling of the flow tubes. Air bubbles inside the flow tubes Foam arising through air contents or decompression effects. Residues from media on the tube walls e.g. wax from hydrocarbons, crystallized media, condensate when measuring gas. Possible electrical reasons: Check the wires and terminals between exciter coil and transmitter. Check exciter wires for short circuit with sensor housing. Remedy: Fill or empty the flow tubes completely – disconnect transmitter from power for min. 30 sec. – reconnect to power.
exc. too small	Detects a too small exciter current / exciter voltage	Check the lines between excitation coil and transmitter. Obligatory in Custody Transfer Mode
QM > 110 %	The mass-flow is 10 % larger than the set measurement range end-value.	Reduce the flow rate and adjust the measuring range if necessary.
OVERFLOW !	Forward or Revers flow totaliser overflow	Reset totaliser; possibly change to a bigger totaliser unit
curr. 1 saturated	The output of current interface 1 is overdriven. Based on the selected settings and the currently assigned measured variable, the current to be output is > 21.6 mA.	Check the upper-range value and the flow rate settings.
curr. 2 saturated	The output of current interface 2 is overdriven. Based on the selected settings and the currently assigned measured variable, the current to be output is > 21.6 mA.	Check the upper-range value and the flow rate settings.
pulse out satur.	The pulse output is overdriven. The current measured value requires a pulse rate, which cannot be generated based on the set values for pulse duration.	Check pulse duration, pulse value, and measuring range. Check the flow rate.

Display (English)	Description	Possible cause of error and remedy
Temperature > MAX	The measured temperature exceeds the set upper-range value for temperature.	Product temperature is too high; adjust the temperature range and the limit values if necessary.
Temperature < MIN	The measured temperature is below the set lower-range value for temperature.	Product temperature is too low; adjust the temperature range and the limit values if necessary.
params inconsist	Set parameters are inconsistent.	Check the parameter settings. The set parameters are conflicting. Example: Upper-range value, pulse value and pulse duration must be matched in such a way that the combination fits for all possible measured values.
ext. EEPROM missing	The Data Memory Chip (DSB) with the sensor calibration data and the customer settings is not accessible.	The BE4 control unit is not correctly seated in its connector socket. Check socket seating.

Table 13: Self-Test Error List

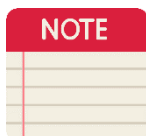

Note:

Error message: "Parameter is inconsistent" (system error 0x0400)?

To generate a list of the inconsistencies, first enter a valid password and then an invalid password. The control unit will show a list of current errors (only once). The operator can then correct the inconsistent settings after again entering a valid password.

8.2.3.2 Display of system error

System errors consist of the message text "system error" and a 4-digit number in hexadecimal code. The meaning of the individual error codes is described in the following table. If several errors occur at the same time, the hexadecimal sum of the individual errors will be displayed. The errors are coded in such a way that the individual errors can be easily identified. The sums are unique.

Descriptor label (never displayed)	Constant/ display	Description
SystemfehlerDiv0	0x0001	Computing fault / Division through Null
SystemfehlerIntEEProm	0x0002	Check sum transmitter data incorrect, New initialisation required
SystemfehlerPruefsumme	0x0004	Check sum Sensor data incorrect.
Systemfehlerleeres EEPROM	0x0008	Ext. EEPROM present but blank / unwritten
SystemfehlerEEPROM	0x0010	Save / Read Memory value failed
SystemfehlerZeitkonstante	0x0800	Initialisation of the time constants failed
SystemfehlerMesswert	0x0200	Error in the calculation of the measured values
SystemfehlerFrequenz	0x0040	Error in the frequency / density measurement
SystemfehlerParameter	0x0400	Settings inconsistent
SystemfehlerRAM_pruefsumme	0x0800	Check sum in the parameter of the Custody transfer measured value
SystemfehlerFLASH_pruefsumme	0x1000	Check sum error in the program memory (Flash-PROM: sector 0xD0000 – 0xDFFFF)
SystemfehlerDSP_pruefsumme	0x0800	Check sum error during communication between DSP and M16
SystemfehlerZaehler	0x0800	Totalisators are two-fold saved. Fault after inconsistency during power up.
SystemfehlerWDG	0x0800	Internal Watchdog: Time limit exceeded
SystemfehlerSchreibfehler	0x0800	Memory cell in working memory (RAM) defect.
Systemfehler DSP Version	0x0080	The firmware of the DSP is not the current issue (not aligned with that of the transmitters operating system)
SystemfehlerDSPKommu	0x2000	Communication between the DSP and microcontroller is disrupted, processing of the measured values does not take place.

Table 14: System errors

8.3 Returning the Meter

If all attempts to return the device to an operational condition have failed, contact our service department to arrange the return of your device for repair.

Before sending the device back for repair or servicing, please ensure the following steps have been performed:

- Always enclose a fully completed declaration of decontamination. You will find a template in section 8.3.1
- Ensure all medium residues have been removed, be sure to clean the seal grooves and recesses thoroughly.
- Provide a description of the encountered problem, providing as much information as possible as well as a contact person for following correspondence.
- Inform us of any special handling requirements you or your processes may have.

8.3.1 Declaration of Decontamination

Company name: Address:

Department: Name of contact person:

Phone:

Information pertaining to the enclosed Coriolis flow meter

Model:

was operated using the following fluid:

In as much as this fluid is water-hazardous / toxic / corrosive / combustible / a health hazard / environmentally hazardous

we have performed the following steps:

- Checked all cavities in the device to ensure that they are free of fluid residues*
- Washed and neutralized all cavities in the device*
- Cleaned all seals/gaskets and other components that came into contact with the measured medium*
- Cleaned the housings and all surfaces*

*tick applicable items

We hereby warrant that no health or environmental hazard will arise from any fluid residues on or in the enclosed device.

Date:

Signature:
(Name in Block)

Company Stamp

9. Declaration of Conformity



EU-Konformitätserklärung
EU-Declaration of Conformity



Nº. 20-4142-01

<p>Hersteller: <i>Manufacturer:</i></p>	<p>Heinrichs Messtechnik GmbH Robert-Perthel-Strasse 9 50739 Köln</p>
<p>Produktbeschreibung: <i>Product description:</i></p>	<p>Coriolis Durchflussmessgerät UMC4 für Verwendung mit der Sensorreihen TM* und HPC Coriolis Flowmeter UMC4 for use with the Sensor series TM* and HPC</p>

Hiermit erklären wir, in alleiniger Verantwortung, dass das oben genannte Messsystem den Anforderungen der folgenden EU-Richtlinien, einschließlich allen bis heute veröffentlichten Änderungen bzw. Nachträgen entspricht:
We declare herewith, in sole responsibility, that the product described above is conform with the provisions of the following EU-directives, including all published changes and amendments as of today:

2014/30/EU (EMC)	EU-Richtlinie über die Elektromagnetische Verträglichkeit <i>EU-Directive relating to electromagnetic compatibility</i>
2014/34/EU (ATEX)	EU-Richtlinie über Geräte zur Bestimmungsgemäße Verwendung in explosionsgefährdeten Bereichen. <i>EU-Directive relating to electrical equipment intended for use in potentially explosive atmospheres</i>
2014/35/EU (LVD)	EU-Richtlinie über die Bereitstellung elektrischer Betriebsmittel zur Verwendung innerhalb bestimmter Spannungsgrenzen auf dem Markt <i>EU-Directive relating to the making available on the market of electrical equipment designed for use within certain voltage limits</i>
2014/68/EU (PED)	EU-Richtlinie zur Harmonisierung der Rechtsvorschriften der Mitgliedstaaten über die Bereitstellung von Druckgeräten auf dem Markt <i>EU-Directive on the harmonisation of the laws of the Member States relating to the making available on the market of pressure equipment</i>

Anhang N und X sind ein integraler Bestandteil dieser Erklärung
Annex N and X are an integral part of this declaration

Köln, den 01.04.2020



Joseph Burke
(Explosionsschutzbeauftragter /
Explosion Protection Representative)



Michael Manderfeld
(Druckgerätebeauftragter /
PED Representative)



Guido Thometzki
(Geschäftsführung / Managing Director)

Kontakt: Tel: +49 (221) 49708-0
Contact: Email: info@heinrichs.eu
 Web: www.heinrichs.eu

Konformitätserklärung-UMC4_20-4142-01.docx

Seite 1 von 3

CE Anhang N zur EU-Konformitätserklärung
Annex N of the EU-Declaration of Conformity



Nº. 20-4142-01

Produktbeschreibung: **Coriolis Durchflussmessgerät UMC4 für Verwendung mit der Sensorreihen TM* und HPC**
 Product description: **Coriolis Flowmeter UMC4 for use with the Sensor series TM* and HPC**

Die Konformität mit den auf Seite 1 genannten Richtlinien diese Erklärung wird nachgewiesen durch die Einhaltung folgenden Normen (abhängig von Gerätvariant):
 Conformity to the Directives referred to on Page 1 of this Declaration is assured through the application of the following standards (depending on version of device):

Richtlinie Direktive	Norm –Ref. Nr. Standard / Ref. Nº.	Ausgabe Edition	Norm Beschreibung Standard Description	UMC4	TM/ TMU/ TME/ TMR	TM-SH	HPC
	DIN EN -						
2014/30/EU	61000-6-2	2011-06	Immunity Industrial enviroment	X			
	61000-6-3	2012-11	Emission residential enviroment	X			
	55011	2011-04	Radio frequency disturbance	X			
	61326-1	2011-07	EMC requirements	X			
2014/34/EU	60079-0	2012+ A11:2013	General requirements	X	X	X	X
	60079-1	2014	Flameproof Enclose „d“	X			
	60079-11	2012	Intrinsic Safety „i“	X	X	X	X
	60079-26	2015	Protection Level (EPL) „Ga“	X	X	X	
2014/35/EU	61010	2011-07	Safety requirements	X	X	X	
2014/68/EU	AD 2000-Merkblätter		Module H		X	X	

X: Zutreffende Norm / Applicable Standard

Name und Anschrift der Notifizierte Stelle / Name and Address of the Notified Body

TÜV-SÜD Industrie Service GmbH
 TÜV SÜD Gruppe
 Westendstraße 199
 D-80686 München
 ID-Nr. / ID-Nº.: RL 2014/68/EU: 0036

DEKRA Testing and Certification GmbH
 Carl-Beyling-Haus
 Dinnendahlstraße 9
 D-44809 Bochun
 ID-Nr. / ID-Nº.: RL 2014/34/EU: 0158





**Anhang X zur EU-Konformitätserklärung
Annex X of the EU-Declaration of Conformity**



Nº. 20-4142-01

Produktbeschreibung: **Coriolis Durchflussmessgerät UMC4 für Verwendung mit der Sensorreihen TM* und HPC**
 Product description: **Coriolis Flowmeter UMC4 for use with the Sensor series TM* and HPC**

Gerät Zulassungen / Device certification

EG-Baumusterprüfbescheinigung EC-type examination certificate	Nachtrag Supplement	Kennzeichnung Marking Für kompletten Kennzeichnung, siehe Betriebsanleitung	UMC4	TM/TMU/ TME/TMR	TM-SH	HPC
BVS 10 ATEX E 110 X	1	II (1) 2G	X			
DMT 01 ATEX E 149 X	7	II 1/2G		X	X	
CML 19 ATEX 2096 X	0	II 1G II 1/2D				X

X: Zutreffende Norm / Applicable Standard

Die oben genannten Produkte entsprechen der Richtlinie 2014/34/EU. Neue Editionen können bereits eine oder mehrere der in den jeweiligen EG-Baumusterprüfbescheinigungen genannten Normen ersetzt haben. Der Hersteller erklärt, dass alle Produkte erwähnt in dieser Konformitätserklärung auch der Anforderungen der neuen Editionen einhalten, da die veränderten Anforderungen der neuen Editionen haben entweder keinen Einfluss auf das Produkt, oder das Produkt die Anforderungen erfüllt.

The above-mentioned products comply with the requirements of Directive 2014/34/EU. New editions may have already replaced one or more of the Standards stated in the respective EC-Type-examination Certificates. The manufacturer declares that all products mentioned in this Declaration of Conformity also comply with the requirements of the new editions since the changed requirements of the new editions either do not affect the product, or the product also fulfills the requirements.

Heinrichs Messtechnik GmbH

Robert-Perthel-Straße 9
50739 Köln
Telefon 0221/49708-0
Telefax 0221/49708-178
<http://www.heinrichs.eu>
info@heinrichs.eu

Bankverbindung

Dresdner Bank Köln
BLZ 370 800 40
Konto-Nr. 0955 051300
IBAN :
DE58 3708 0040 0955 0513 00
SWIFT-BIC: DRES DE FF 370

Erfüllungsort und Gerichtsstand:

Köln
Amtsgericht Köln HRA 37040
Ust.IDNr.: DE813416533
Steuer-Nr.: 217/5743/0386

Geschäftsführer

Dipl. Ing. (FH)
Guido Thometzki

Heinrichs Messtechnik GmbH
Robert-Perthel-Straße 9
D 50739 Cologne
Germany
Telephone: +49 (221) 4 97 08 - 0
Telefax: +49 (221) 4 97 08 - 178
Internet: <http://www.heinrichs.eu>
Email : info@heinrichs.eu

We reserve the right to make
amendments to the technical
specifications without notice

Printed in Germany

File Name:
TMU-W_UMC4_BA_20.02_EN.DOCX

Number of Pages 118