

RTD Sensor with Built-in Temperature Transmitter

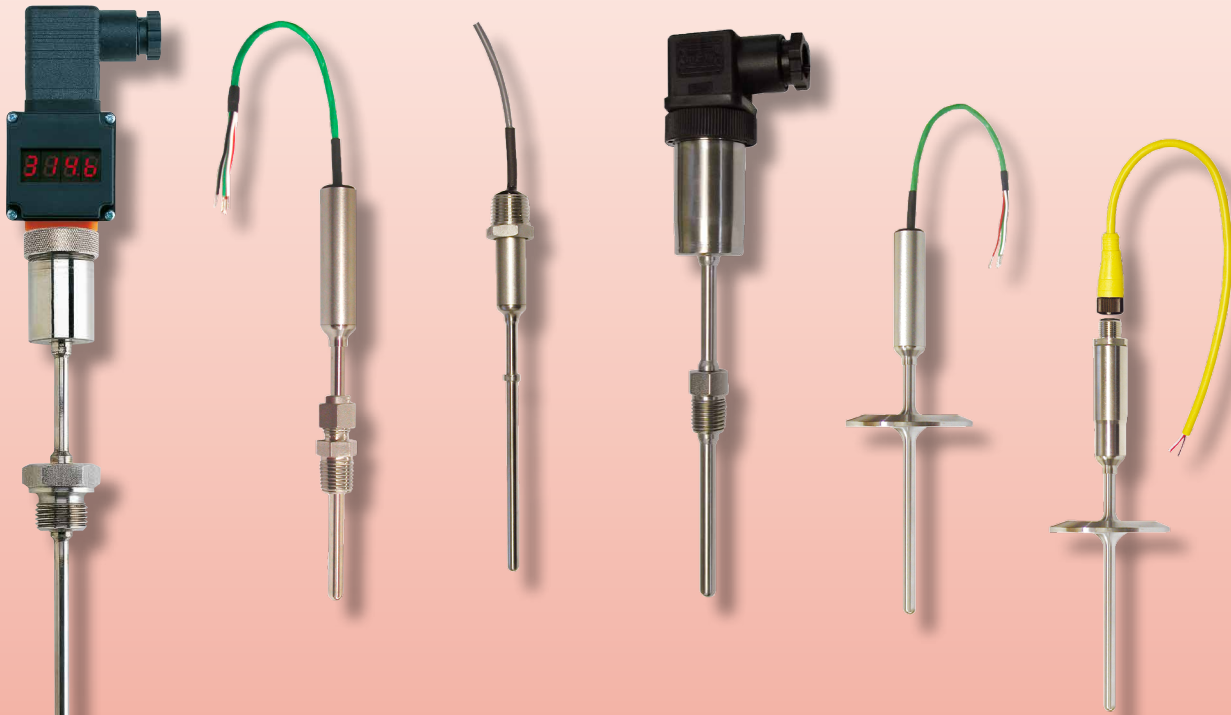

measuring
•
monitoring
•
analyzing

TST



- RTD Sensor with Built-in Transmitter
- Factory Calibrated
- Compact and Economical
- Easy Installation
- Microprocessor Based Design
- Sanitary Versions Available
- Hermetically Sealed Transmitter
- Field Calibration or Re-span via PC Interface
- Optional Plug-on Display
- Linearized 4-20 mA, 0-5 VDC, 1-5 VDC, or 0-10 VDC Signal Outputs



KOBOLD companies worldwide:

ARGENTINA, AUSTRALIA, AUSTRIA, BELGIUM, BULGARIA, CANADA, CHILE, CHINA, COLOMBIA, CZECH REPUBLIC, EGYPT, FRANCE, GERMANY, HUNGARY, INDIA, INDONESIA, ITALY, MALAYSIA, MEXICO, NETHERLANDS, PERU, POLAND, REPUBLIC OF KOREA, ROMANIA, SINGAPORE, SPAIN, SWITZERLAND, TAIWAN, THAILAND, TUNISIA, TURKEY, UNITED KINGDOM, USA, VIETNAM

KOBOLD Instruments, Inc.
1801 Parkway View Drive
Pittsburgh, PA 15205
☎ Main Office:
1.800.998.1020
1.412.788.4890
✉ info@koboldusa.com
www.koboldusa.com



Description

The TST is an RTD sensor with a built-in transmitter, which is programmable by a computer. The transmitter is hermetically sealed into the potting adaptor of the probe. As such, it is very compact, is vibration resistant, and is one of the most advanced designs available in the market. The TST is ideal for areas with space limitations where traditional head connectors are too large to fit. It is accurate straight out of the box!

The TST comes factory calibrated to a standard measuring range or any customer specified range. The unique transmitter design allows it to be calibrated in the field using a cable and a Windows™ compatible software package. Temperature range, temperature offset, burnout options and other features can be selected without the need for recalibration. Of course, the software also allows for calibration. The ability to calibrate in the field is where the TST leaves the competition behind.

The TST is available in either NPT or Tri-clamp versions. Special finishes for food and the dairy industry are available. The hermetically sealed transmitter and external cables will withstand the harshest of washdowns.

Specifications for Non-Sanitary Models

Measuring Ranges:	-58...400 °F (for other ranges consult factory)
Maximum Pressure	
NPT Fitting:	1500 PSIG
Materials	
Measuring Probe:	316 Stainless Steel
Cable:	PVC, PTFE, SS Braid FEP or SS Armored FEP
Ambient Temperature:	-40...158 °F
Storage Temperature:	-50...158 °F
Output Type	
RTD:	Pt-100, DIN/EN 60751 Class A
Current:	4-20 mA, 2-wire
Voltage:	0-5, 1-5, or 0-10 VDC, 3-wire
Power Requirement	
Current:	9-30 VDC Loop Powered, Max. Loop Resistance: 50 (V _{supply} - 7)
Voltage:	12-30 VDC
Accuracy:	± 0.1% of Span
Zero Drift:	± 0.025% / °F
Span Drift:	± 0.025% / °F
Electrical Connection:	6 ft. Jacketed Cable, DIN 43650 Hirschmann Plug, M12 Micro-DC 5-pin, or 6 ft. Jacketed Cable with optional 1/2" NPT Conduit Hub
Electrical Protection:	NEMA 6P

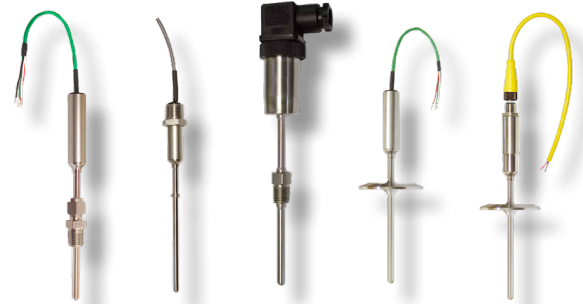

Specifications for Tri-clamp® Models

Measuring Ranges:	-58...302 °F
Maximum Pressure:	500 PSIG Tube Section
Materials	
Probe:	316 Stainless Steel
Cable:	PVC, FEP, or Stainless Steel Armored FEP
Ambient Temperature:	-40...158 °F
Storage Temperature:	-58...158 °F
Input:	Pt-100, DIN/EN 60751 Class A
Output Type:	4-20 mA, 2-wire 0-5, 1-5, or 0-10 VDC, 3-wire
Power Supply:	9-30 VDC for Current Output Versions 12-30 VDC for Voltage Output Versions, Polarity Protected
Max. Loop Resistance:	[40* (V _{supply} - 7)] ohms
Accuracy:	± 0.1% of Span
Zero Drift:	± 0.025% / °F
Span Drift:	± 0.025% / °F
Sensor Open Current:	Upscale 24 mA or Downscale 2.5 mA
Warm-Up Time:	30 Seconds
Isolation:	500 VDC Input/Output
Long-Term Drift:	≤ 0.1% FS/Year
Electrical Connection	
Standard:	6 ft. Jacketed Cable
Optional:	DIN 43650 Hirschmann Plug, 6 ft. Jacketed Cable with 1/2" NPT Conduit Hub or M12 Micro-DC 5-pin
Electrical Protection:	NEMA 6P (IP 67)
Surface Finish	
Standard:	Polished to #4 Finish per 3A Standard 74-06, 32 micro-inches Max.
Pharmaceutical:	Polished to Mirror Finish and Passivated, 10 micro-inches Typical



Order Details (Example: **TST-00 040 PV 06 C**)

Model	Fitting	Immersion Depth (Dim. "U")	Electrical Connection	Range	Options
TST-	..00.. = Smooth Shank, (1/4" Probe Dia. Only)	..025.. = 2.5"	..PV.. = 6 ft. PVC-Jacketed (212 °F Max.)	..02 = 0...120 °F	..NE = No Extension (1" Std)
	..A2.. = 1/4" NPT, Adj. (Dim. F = 1.5")	..040.. = 4.0"	..TF.. = 6 ft. FEP-Jacketed	..04 = 0...200 °F	..C = 1/2" NPT Conduit Connection
	..A4.. = 1/2" NPT, Adj. (Dim. F = 1.71")	..060.. = 6.0"	..TA.. = 6 ft. 316 SS-Armored FEP	..06 = 0...300 °F	..EC = Extended Cable Length (Specify Length)
	..F2.. = 1/4" NPT, Fixed (Dim. F = 1.0")	..090.. = 9.0"	..TB.. = 6 ft. 316 SS-Braid FEP	..08 = 0...400 °F	..V1 = 0-5 VDC Output in Place of the Standard 4-20 mA
	..F4.. = 1/2" NPT, Fixed (Dim. F = 1.12")	..120.. = 12"	..H.. = DIN 43650A Hirschmann Plug	..10 = 32...212 °F	..V2 = 1-5 VDC Output in Place of the standard 4-20 mA
	..T15.. = 1.5" Hygienic Clamp (16 AMP)	..180.. = 18"	..M12.. = Micro-DC, 5-pin Male	..12 = -58...392 °F	..V3 = 0-10 VDC Output in Place of the standard 4-20 mA
	..T2.. = 2" Hygienic Clamp (16 AMP)	..240.. = 24"		..18 = -58...120 °F	
	..T25.. = 2.5" Hygienic Clamp (16 AMP)	..EP.. = Custom Depth (Specify when Ordering)		..E = Custom Scale (Specify Range)	
	..T3.. = 3" Hygienic Clamp (16 AMP)				
Accessory Items (Order as Separate Part Numbers)					
TST-PKIT2 = Field Calibration Kit (Includes: USB Cable, Communication Interface Module, and Windows™ Compatible Software (see below)) 807.007 = 5-pin Micro-DC connecting cable, 2 meters in length for electrical connection type ..M12.. 807.007 / 5M = 5-pin Micro-DC connecting cable, 5 meters in length for electrical connection type ..M12.. 807.007 / 10M = 5-pin Micro-DC connecting cable, 10 meters in length for electrical connection type ..M12..					

Description: TST-PKIT2 Field Calibration Kit

The TST Field Calibration Kit allows the user to rescale the output transmitter span as well as perform single point and multipoint field calibration all via a PC USB interface.

Included in the Kit:

- Communication Interface Module that allows the TST to be connected to a PC USB Port
- USB Cable
- Windows™ Compatible Software

Minimum System Requirements:

- 1 MB of Hard Drive Free Space
- Windows™ XP, 7, or newer
- 1 free USB port

Connecting the TST:

- Strip away the shrink tube at the end of the signal cable to expose the programming lines.
- Connect the power, signal, and programming lines to the interface module via the screw terminal according to the diagram below.
- Connect the interface module to the PC's USB Port

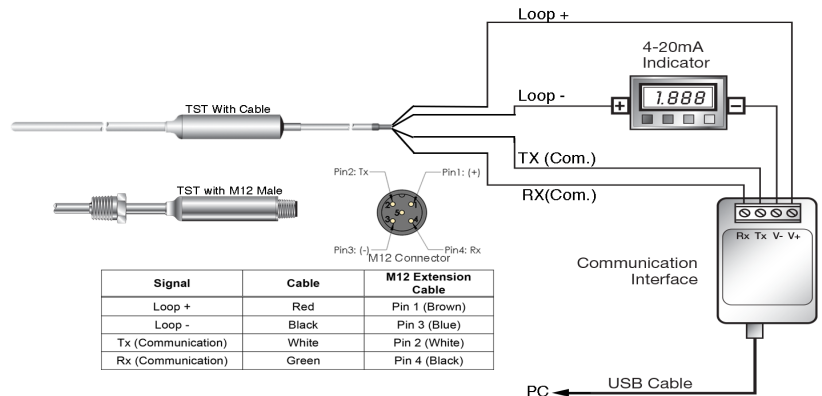

Dimensions

Fitting Option ..00..

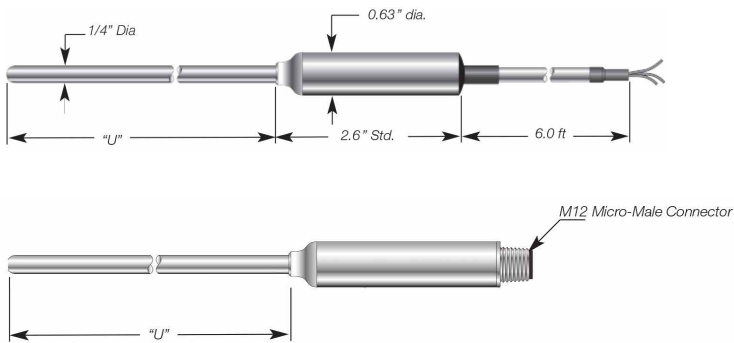

Fitting Options ..A2.. and ..A4..

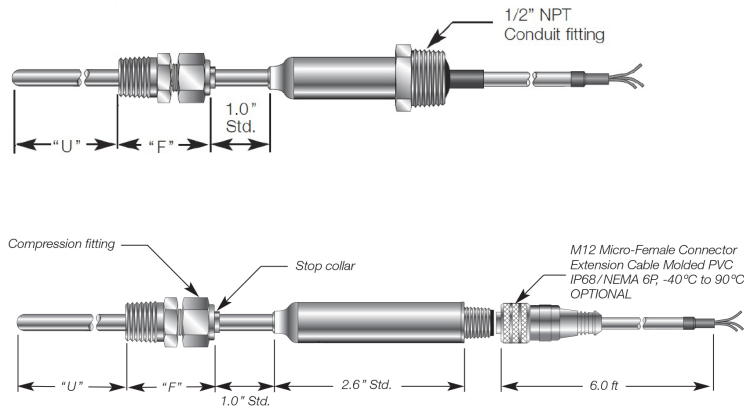

Fitting Options ..F2.. and ..F4..

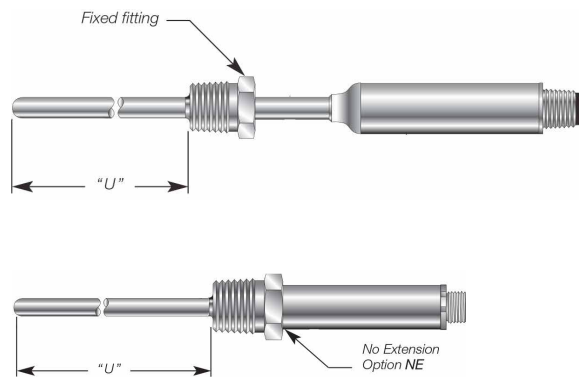

Tri-clamp® Fitting Options

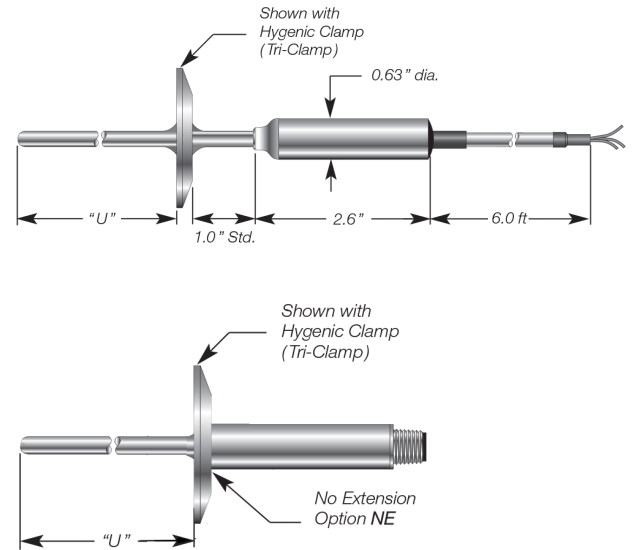

Fitting Options ..F2.. and ..F4.., Shown with Electrical Connection ..H..

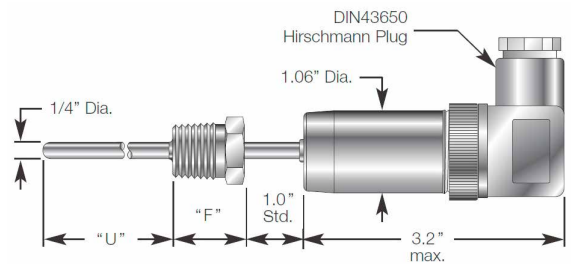

Optional Plug-on Display Model AUF
see AUF product datasheet for ordering details

