

Operating Instructions for Bypass Level Indicator

Model: NBK



1. Contents

| | |
|---|----|
| 1. Contents..... | 2 |
| 2. Note | 3 |
| 3. Instrument Inspection..... | 4 |
| 4. Regulation Use..... | 5 |
| 4.1. Bypass Measuring Tube System..... | 5 |
| 5. Operating Principle..... | 6 |
| 6. Mechanical Connection | 7 |
| 7. Commissioning..... | 8 |
| 8. Trouble Shooting | 9 |
| 9. Maintenance..... | 9 |
| 10. Technical Information..... | 10 |
| 11. Options..... | 12 |
| 12. Order Codes | 17 |
| 13. Dimensions..... | 18 |
| 14. Disposal..... | 29 |
| 15. EC Declaration of Conformance | 30 |

Manufactured and sold by:

Kobold Messring GmbH
Nordring 22-24
D-65719 Hofheim
Tel.: +49(0)6192-2990
Fax: +49(0)6192-23398
E-Mail: info.de@kobold.com
Internet: www.kobold.com

2. Note

Please read these operating instructions before unpacking and setting the unit into operation. Follow the instructions precisely as described herein.

The instruction manuals on our website www.kobold.com are always for currently manufactured version of our products. Due to technical changes, the instruction manuals available online may not always correspond to the product version you have purchased. If you need an instruction manual that corresponds to the purchased product version, you can request it from us free of charge by email (info.de@kobold.com) in PDF format, specifying the relevant invoice number and serial number. If you wish, the operating instructions can also be sent to you by post in paper form against an applicable postage fee.

The devices are only to be used, maintained and serviced by persons familiar with these operating instructions and in accordance with local regulations applying to Health & Safety and prevention of accidents.

When used in machines, the measuring unit should be used only when the machines fulfil the EC-guidelines.

Classification according to Pressure Equipment Directive 2014/68/EU NBK-03 to NBK-33

| Category assignment for dangerous media (from diagram 1) | | | | | | | | | | | | |
|--|----------------------------------|-------------|-------------------|------------|------------|------------|-------------|------------|--------------|-------------|----------|------------|
| | Density [kg/dm ³] | PN [bar] | Category | ML [mm] | Category | ML [mm] | Category | ML [mm] | Category | ML [mm] | Category | ML [mm] |
| NBK-03 | 1,0 | 16 | ← Art.4, Para. 3← | ≤317 | ← Cat. I → | 945 | ← Cat. II → | 4711 | ← Cat. III → | 24795 | - / - | |
| | 0,9/0,8/0,7/ 0,6/0,54 | | | ≤207 | | 835 | | 4600 | | 24685 | - / - | |
| NBK-06 | 1,0 | 40 | | | | 192 | | 1698 | | 9732 | ∞ | |
| | 0,9/0,8/0,7 | | | 82 | 1588 | 9622 | | ∞ | | | | |
| NBK-07 | 1,0 | 63 | | | 128 | 1060 | | 6504 | | ∞ | | |
| | 0,9/0,8/0,7 | | | 18 | 950 | 6394 | | ∞ | | | | |
| NBK-10 | 1,0 | 100 | | | 140 | 577 | 4084 | ∞ | | | | |
| | 0,9/0,8 | | | 30 | 467 | 3974 | ∞ | | | | | |
| NBK-31 | 1,0 | 160 | | | | | | ≤2090 | | ← Cat. IV → | 5600 | |
| | 0,9 | | | | | | | ≤2020 | | | 5600 | |
| | 0,8 | | | | | | | ≤1900 | | | 5400 | |
| NBK-32 | 1,0 | 250 | | | | | | ≤1180 | | | 5600 | |
| | 0,9 | | | | | | ≤1110 | 5600 | | | | |
| | 0,8 | | | | | | ≤985 | 5400 | | | | |
| NBK-33 | 1,0 | 320 | | | | | ≤1040 | 5600 | | | | |
| | 0,9 | | | | | | ≤970 | 5500 | | | | |
| | 0,8 | | | | | | ≤830 | 5400 | | | | |

ATTENTION! If the calculated bypass length is exactly within the range limit, then the stricter test method must be used

Classification according to Pressure Equipment Directive 2014/68/EU NBK-03 to NBK-33

| Category assignment for not dangerous media (from diagram 2) | | | | | | | | | | | | | |
|--|----------------------------------|-------------|---------------------|------------|------------|------------|-------------|------------|--------------|------------|-------------|------------|-------|
| | Density [kg/dm ³] | PN [bar] | Category | ML [mm] | Kategorie | ML [mm] | Category | ML [mm] | Category | ML [mm] | Category | ML [mm] | |
| NBK-03 | 1,0 | 16 | ← Art.4, Para. 3- → | ≤945 | ← Cat. I → | 4711 | ← Cat. II → | 24795 | ← Cat. III → | 75007 | - / - | | |
| | 0,9/0,8/0,7/0,6/0,54 | | | ≤835 | | 4600 | | 24685 | | 74897 | - / - | | |
| NBK-06 | 1,0 | 40 | | ≤192 | | 1698 | | 9732 | | 29816 | - / - | | |
| | 0,9/0,8/0,7 | | | ≤82 | | 1588 | | 9622 | | 29706 | - / - | | |
| NBK-07 | 1,0 | 63 | | ≤128 | | 1060 | | 6504 | | 20112 | ← Cat. IV → | ∞ | |
| | 0,9/0,8/0,7 | | | ≤18 | | 950 | | 6394 | | 20002 | | ∞ | |
| NBK-10 | 1,0 | 100 | | ≤140 | | 577 | | 4084 | | 12849 | | ∞ | |
| | 0,9/0,8 | | | ≤30 | | 467 | | 3974 | | 12739 | | ∞ | |
| NBK-31 | 1,0 | 160 | | | | | | | | ≤2090 | | 5600 | - / - |
| | 0,9 | | | | | | | | | ≤2020 | | 5600 | - / - |
| | 0,8 | | | | | | | | | ≤1900 | | 5400 | - / - |
| NBK-32 | 1,0 | 250 | | | | | | | | ≤1180 | | 4410 | 5600 |
| | 0,9 | | | | | ≤1110 | 4340 | 5600 | | | | | |
| | 0,8 | | | | | ≤985 | 4220 | 5400 | | | | | |
| NBK-33 | 1,0 | 320 | | | | ≤1040 | 4090 | 5600 | | | | | |
| | 0,9 | | | | | ≤970 | 4010 | 5500 | | | | | |
| | 0,8 | | | | | ≤830 | 3870 | 5400 | | | | | |

ATTENTION! If the calculated bypass length is exactly within the range limit, then the stricter test method must be used

3. Instrument Inspection

Instruments are inspected before shipping and sent out in perfect condition. Should damage to a device be visible, we recommend a thorough inspection of the delivery packaging. In case of damage, please inform your parcel service / forwarding agent immediately, since they are responsible for damages during transit.

Scope of delivery:

The standard delivery includes:

- Bypass Level Indicator model: NBK

4. Regulation Use

Any use of the Bypass level Indicator, model: NBK, which exceeds the manufacturer's specification may invalidate its warranty. Therefore, any resulting damage is not the responsibility of the manufacturer. The user assumes all risk for such usage.

The NBK Bypass Level Indicator is used for continuous measurement, indication, and monitoring of liquids in tanks, vessels, reservoirs, basins etc. The indication occurs via a magnetically coupled roller indicator.

4.1. Bypass Measuring Tube System

The bypass tube is attached at the side of the vessel with a connecting flange or a threaded pipe. The installation position is always vertical. The NBK should only be used for liquids with the medium density specified on the nameplate. Otherwise, the indication will deviate (float too high or submerged).

Vessel inner pressure and medium temperature should not exceed the specified maximum values, as this can lead to the destruction and malfunction of the bypass system. It is imperative that the materials used are compatible with the liquid being measured.

Proper operation is also impaired by:

- High degree of soiling
- Suspended solids
- Crystallisation
- Ferrite particles

5. Operating Principle

Kobold Bypass Level Indicators are used for continuous measurement, display and monitoring of liquid levels. The bypass tube is attached onto the side wall of the vessel. According to the law of communicating tubes the level in the bypass tube equals the level in the vessel. A float with embedded circular magnets in the bypass tube follows the liquid level and transfers it in a non-contacting manner to a display fitted outside the tube or to a monitoring device. The following indication and monitoring devices are available:

Magnetic roller indicator

As the float passes by, the red/white* rollers/balls are rotated in succession by 180° around their own axes. The rollers change from white to red as the level rises and from red to white as the level falls. The advantage of ball displays is the higher protection category, good visibility of 180 ° and higher vibration resistance with filled version. The level in a tank or a mixer is continuously displayed as a red column, even when the power supply fails.

* ceramic rollers in orange/beige

Transmitter

To remotely transmit the level a transmitter with an immersible magnetic probe (chain of resistors) or a magnetostrictive transducer can be mounted outside the bypass tube. The contacts of a reed contact chain are connected or disconnected via the float movement in a non-contacting manner. Depending on the level the number of connected resistors changes and as a consequence the output of the total resistor value. A continuous standard signal of 4 to 20 mA is generated by means of a fitted transmitter. This standard signal can then be displayed on analogue or digital indicating devices. Communication controls HART®, PROFIBUS® - PA or FOUNDATION™ Fieldbus are optional.

Universal indicating unit

A universal indicating unit of type series ADI can be mounted on the bypass to display and evaluate the standard signal (4–20 mA) generated by the transmitter.

Limit contacts

One or more reed contacts for limit-value acquisition or also for level control can be attached to the bypass tube.

6. Mechanical Connection

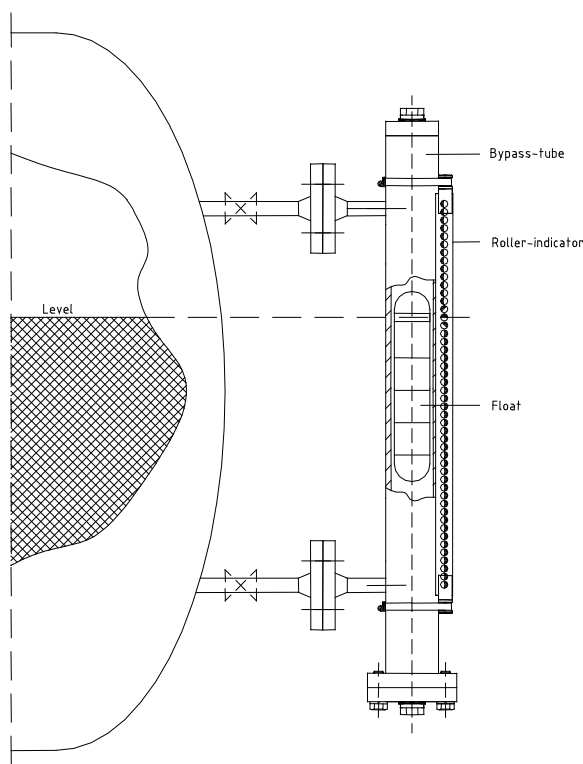

Remove bottom flange from bypass tube, and insert the cylindrical float in the NBK bypass tube with the designation "TOP" at the top. Reposition the gasket and close the bottom flange again; firmly tighten with screws.

Mount the bypass tube to the vessel to be monitored via the process connection and seal with an appropriate device. Normally it is sufficient to fix the complete NBK with both process connections. However, should the NBK be subjected to constant shock or strong vibrations it is recommended that the instrument is secured with rubber-damped tube clips. No welding is allowed on the bypass tube.

Mount and tighten the **magnetic roller indicator** - if not already mounted - on the bypass tube with the two provided ribbon clamps.

7. Commissioning

Because of the setting behaviour of seals, all screw connections must be retightened.

Fill vessel and switch on electrical controller, if available. If there are gate valves between bypass process connection and tank, first slowly open the upper valve (pressure relief) and then the lower valve (liquid side). If vent and drain valves have been installed, close them before filling.

The liquid that now enters the bypass tube raises the float until the level between tank and bypass tube is balanced. The roller indicator indicates the liquid level.



For media with high operating temperatures, the surface of the level indicator also heats up. The operator must take appropriate measures to prevent accidental contact with such surfaces (protective cage). If this is not structurally possible under certain conditions, appropriate protective clothing must be worn in the area of the level indicator.

8. Trouble Shooting

Error: The tank is full but there is no indication

- Check that both flanges (process connection), top and bottom, are open to the vessel, and that the bypass tube fills with liquid.
- Check that there is a float in the system.
- When the float is installed, check whether it is being blocked by foreign objects or dirt deposits.

Error: The tank is full but the indication is too low.

- Check that the density of the liquid is the same as the density given on the nameplate.
- Check that the float has been correctly installed with the marking "TOP" at the top.
- Check if dirt deposits in the bypass tube are blocking the float.

9. Maintenance

The drain plug should be opened occasionally, to wash out any deposits in case the liquid to be measured contains dirt particles, which could settle in the bypass tube.

If crust formation or crystallisation has taken place, the tank must be emptied or shut off; the lower cover flange must then be removed. The float should then be removed carefully out of the bypass. The bypass tube can now be mechanically cleaned.

The inspection window for the roller indication is made of high-quality plexiglass (glass for high-temperature display). It should be cleaned with a suitable cleaning agent.

The indicator requires no further maintenance.

10. Technical Information

| | |
|------------------------|--|
| Process Connection: | Flange DIN EN 1092-1, type 11, form B1 DN 15, DN 20, DN 25, DN 32 DN 40, DN 50 Flange ASME B 16.5-2009 RF ½", ¾", 1", 1¼", 1½", 2" R-thread DIN EN 10226-1 ½", ¾", 1", 1¼" NPT ANSI/ASME B1.20.1 ½", ¾", 1", 1¼" |
| Bypass tube: | Ø 60.3 mm, 1.4571 (NBK-03/ ... /10) Ø 71.0 mm, 1.4571 (NBK-31) Ø 76.1 mm, 1.4571 (NBK-32/33) |
| NBK-03,-06,-07: | flat gasket: <200 °C: PTFE; ≥200 °C: Klinger SIL® |
| NBK-10: | reinforced graphite |
| NBK-31/32/33: | RTJ-seal |
| Operating pressure: | PN 16/40/63/100/160/250/320 |
| Operating temperature: | -20...+120 °C (POM rollers) -40...+400 °C (ceramic rollers) -104...+200 °C (ball display) -60...+100 °C (NBK-31, -32, -33) |
| Viscosity: | max. 200 mm ² /s standard (Option: up to max. 460 mm ² /s for NBK-03) |
| Max. measuring length: | up to 5500 mm: single-part, longer two-part or multipart |
| Overall length: | see dimension drawing |
| ATEX approval: | see separate datasheet |

Roller display RP (max. length 5500 mm)

| | |
|-------------------------|---------------------------|
| Material roller: | POM |
| Display glass: | PMMA |
| Carrier frame material: | Aluminium, black anodised |
| Medium temperature: | -20 °C...+120 °C |
| Ambient temperature: | -20...+80 °C |
| Protection: | IP54 |

Roller display RK (max. length 5500 mm)

| | |
|-------------------------|---------------------------|
| Material roller: | Ceramic |
| Display glass: | Borosilicate glass |
| Carrier frame material: | Aluminium, black anodised |
| Medium temperature: | -40 °C...400 °C |
| Ambient temperature: | -40...+250 °C |
| Protection: | IP54 |

Ball display model KP (max. length 3800 mm one-piece)*

| | |
|----------------------|--|
| Material ball: | PA |
| Sight tube: | PMMA |
| Sealing plug: | Aluminium |
| Seal: | NBR |
| Ball support rail: | Aluminium, black anodised |
| Carrier frame: | Stainless steel 1.4301 |
| Scale: | PVC, stainless steel 1.4301 (option M) |
| Medium temperature: | -20...+80 °C |
| Ambient temperature: | -20...+80 °C |
| Protection: | IP66 |

Ball display model KM (max. length 3800 mm one-piece)*

| | |
|----------------------|---|
| Material ball: | PA – high temperature strength |
| Sight tube: | PC |
| Sealing plug: | Aluminium |
| Seal: | FKM |
| Ball support rail: | Aluminium, black anodised |
| Carrier frame: | Stainless steel 1.4301 |
| Scale: | PVC, stainless steel 1.4301 (option MV) |
| Medium temperature: | -60...+120 °C |
| Ambient temperature: | -20...+80 °C |
| Protection: | IP66 |

Ball display model KF (max. length 3800 mm one-piece)*





| | |
|----------------------|---|
| Filling: | silicone oil |
| Material ball: | PA – high temperature |
| Sight tube: | PC |
| Sealing plug: | Stainless steel, 1.4571 |
| Seal: | FKM |
| Ball support rail: | Aluminium, black anodised |
| Carrier frame: | Stainless steel 1.4301 |
| Scale: | PVC, stainless steel 1.4301 (option MV) |
| Medium temperature: | -104...+120 °C |
| Ambient temperature: | -20...+80 °C |
| Protection: | IP66 |

Ball display model KG (max. length 3000 mm one-piece)*

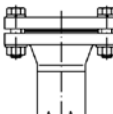
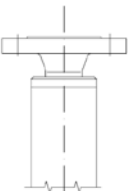
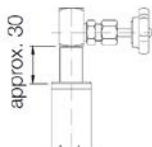

| | |
|----------------------|--------------------------------|
| Material ball: | PA – high temperature strength |
| Sight tube: | Borosilicate glass |
| Sealing plug: | Stainless steel, 1.4571 |
| Seal: | FKM |
| Ball support rail: | Aluminium, black anodised |
| Carrier frame: | Stainless steel 1.4301 |
| Scale: | stainless steel 1.4301 |
| Medium temperature: | -20...+200 °C |
| Ambient temperature: | -20...+200 °C |
| Protection: | IP66 |

* in case of multi-port design, a display length from 32 mm is not readable

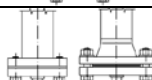
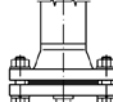
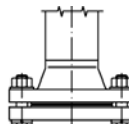
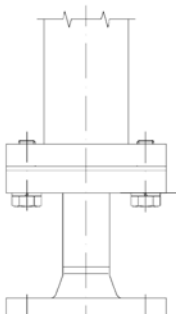
11. Options

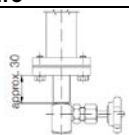
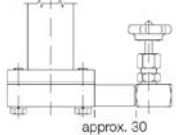
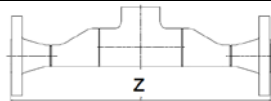
| Code | Description | Sketch/picture | Availability | |
|---------------------------------------|---|--|---|-----------|
| Top bypass tube connections | | | | |
| V0 | Without vent plug |  | NBK-03/06/07 NBK-10/31/32/33, standard | |
| VG | With vent plug G 1/2" (DIN flange) 1/2" NPT (ASME flange) |  | NBK-10 NBK-03/06/07, standard | |
| VF ¹⁾³⁾ | Flange connection DN50 (pressure rating as process flange) |  | NBK-03/06/07/10 | |
| VA ¹⁾³⁾ | Flange connection 2" ASME (pressure rating as process flange) | | NBK-03/06/07/10 | |
| V4 ³⁾ | Vent flange DN15, stainless steel 1.4571 (pressure rating as process flange) |  | NBK-03/06 | |
| V5 ³⁾ | Vent flange DN20, stainless steel 1.4571 (pressure rating as process flange) | | NBK-03/06 | |
| V6 ³⁾ | Vent flange DN25, stainless steel 1.4571 (pressure rating as process flange) | | NBK-03/06 | |
| V7 ³⁾ | Vent flange 1/2" ASME, stainless steel 1.4571 (316 Ti) (pressure rating as process flange) | | NBK-03/06 | |
| V8 ³⁾ | Vent flange 3/4" ASME, stainless steel 1.4571 (316 Ti) (pressure rating as process flange) | | NBK-03/06 | |
| V9 ³⁾ | Vent flange 1" ASME, stainless steel 1.4571 (316 Ti) (pressure rating as process flange) | | NBK-03/06 | |
| V2 | Vent valve NAD-MMN15, 1/2" NPT, stainless steel 1.4571 (316 Ti), max. temp.: +120 °C | |  | NBK-03/06 |
| V3 | Vent valve NAD-MMR15, G 1/2, stainless steel 1.4571, max. temp.: +120 °C | | | NBK-03/06 |
| Bottom bypass tube connections | | | | |
| D0 | Without drain plug |  | NBK-03/06 NBK-10/31/32/33 standard | |
| DG | With drain plug G 1/2" (DIN flange) 1/2" NPT (ASME flange) | NBK-03/06  NBK-07/10 | NBK-10 NBK-03/06/07, standard | |
| DF | Flange connection DN50 (pressure rating as process flange), with drain plug G 1/2" |  | NBK-03/06 | |
| DA | Flange connection 2" ASME (pressure rating as process flange), with drain plug 1/2" NPT | | NBK-03/06 | |
| DC | Flange connection DN50 (pressure rating as process flange), without drain plug |  | NBK-03/06/07 | |
| DD | Flange connection 2" ASME (pressure rating as process flange), without drain plug | | NBK-03/06/07 | |
| E4 | Drain flange DN15, stainless steel 1.4571 (pressure rating as process flange) |  | NBK-03/06 | |
| E5 | Drain flange DN20, stainless steel 1.4571 (pressure rating as process flange) | | NBK-03/06 | |
| E6 | Drain flange DN25, stainless steel 1.4571 (pressure rating as process flange) | | NBK-03/06 | |
| E7 | Drain flange 1/2" ASME, stainless steel 1.4571 (316 Ti) (pressure rating as process flange) | | NBK-03/06 | |
| E8 | Drain flange 3/4" ASME, stainless steel 1.4571 (316 Ti) (pressure rating as process flange) | | NBK-03/06 | |
| E9 | Drain flange 1" ASME, stainless steel 1.4571 (316 Ti) (pressure rating as process flange) | | NBK-03/06 | |

| Code | Description | Sketch/picture | Availability |
|---|---|--|--------------------------|
| F1 | Drain valve NAD-MMR15, G ½, stainless steel 1.4571, max. temp.: +120 °C |  | NBK-03/06 |
| F2 | Drain valve NAD MMN15, ½" NPT, stainless steel 1.4571 (316 Ti), max. temp.: +120 °C | | NBK-03/06 |
| DS | Drain socket DN15 | see sketch | NBK-03 |
| D2 | Drain valve NAD-MMN15, ½" NPT, horizontally mounted, stainless steel 1.4571 (316 Ti), max. temp.: +120 °C |  | NBK-03/06 |
| D3 | Drain valve NAD-MMR15, G ½, horizontally mounted, stainless steel 1.4571 (316 Ti), max. temp.: +120 °C | | NBK-03/06 |
| RF | Dead space free version DN25, stainless steel 1.4571 (pressure rating as process flange) |  | NBK-06 |
| RA | Dead space free version 1" ASME, stainless steel 1.4571 (316 Ti), (pressure rating as process flange) | | NBK-03/06 |
| Process connection options | | | |
| ST ³⁾ | 1 x process connection side, 1 process connection vertical on top | see sketch | NBK-03/06/07/10 |
| TS ³⁾ | 1 x process connection side, 1 process connection vertical at bottom | see sketch | NBK-03/06/07/10 |
| TT ³⁾ | 2 x process connection vertical, up to DN25 or 1" ASME | see sketch | NBK-03/06/07/10 |
| Scales | | | |
| (Ball displays are always delivered with scales, see technical data/sketch for resolution) | | | |
| MV | Scale made of stainless steel 1.4301 (only with ball display model KP/KM/KF, standard with model KG) | see sketch | NBK-03/06/07/10/31/32/33 |
| M1 | Measuring scale, medium temperature -40 °C...+400 °C, engraved scale made of aluminium | see sketch | NBK-03/06/07/10/31/32/33 |
| M2 | Measuring scale, medium temperature -40 °C...+150 °C, scale backing made of aluminium with polyester foil | see sketch | NBK-03/06/07/10/31/32/33 |
| Thermal screening | | | |
| N | Thermal screening for sensor | see sketch | NBK-03/06/07/10/31/32/33 |
| Display options | | | |
| Heating jacket | | | |
| L1 | Connection for heating jacket DN 15/PN 16 Form B1 DIN-EN 1092-1 | see sketch | NBK-03/06/07/10 |
| L2 | Connection for heating jacket DN 20/PN 16 Form B1 DIN-EN 1092-1 | | NBK-03/06/07/10 |
| L3 | Connection for heating jacket DN 25/PN 16 Form B1 DIN-EN 1092-1 | | NBK-03/06/07/10 |
| L4 | Connection for heating jacket DN 32/PN 16 Form B1 DIN-EN 1092-1 | | NBK-03/06/07/10 |
| LA | Connection for heating jacket ½" Class 150 RF ASME B16.5-2003 (Class 300 flanges on request) | | NBK-03/06/07/10 |
| LB | Connection for heating jacket ¾" Class 150 RF ASME B16.5-2003 (Class 300 flanges on request) | | NBK-03/06/07/10 |
| LC | Connection for heating jacket 1" Class 150 RF ASME B16.5-2003 (Class 300 flanges on request) | | NBK-03/06/07/10 |
| LD | Connection for heating jacket 1¼" Class 150 RF ASME B16.5-2003 (Class 300 flanges on request) | | NBK-03/06/07/10 |
| Electrical outputs | | | |
| MU | Option M with connection box at bottom, for easy access to connection box | | NBK-03/06/07/10/31/32/33 |
| MS | Option M with connection box at 100 mm distance, max. medium temperature = +300 °C (Thermal screening option N mandatory with this option) | | NBK-03/06/07/10/31/32/33 |
| MK | Option and connection box 5000 mm silicone cable, max. medium temperature = +400 °C (Thermal screening option N mandatory with this option) | | NBK-03/06/07/10/31/32/33 |

| Code | Description | Sketch/picture | Availability |
|---------------------------|---|--|--------------------------|
| Display options | | | |
| AE | Aluminium die-cast housing, LED digital display, connection box at bottom (only in combination with transmitter option A) |  | NBK-03/06/07/10/31/32/33 |
| AC | Aluminium die-cast housing, LCD digital display, connection box at bottom (only in combination with transmitter option A) | as AE, however with LCD display | NBK-03/06/07/10/31/32/33 |
| HE | Aluminium die-cast housing, LED digital display, connection box at bottom (only in combination with transmitter option H) |  | NBK-03/06/07/10/31/32/33 |
| HC | Aluminium die-cast housing, LCD digital display, connection box at bottom (only in combination with transmitter option H) | as HE, however with LCD display | NBK-03/06/07/10/31/32/33 |
| C ²⁾ | Indicating unit ADI-1 with bargraph and digital display, rugged aluminium housing, mounted at bypass tube, for description see data sheet ADI-1 | see cover page / sketch | NBK-03/06/07/10/31/32/33 |
| Additional options | | | |
| A | Connection flange for 2-part version (not possible with sensor), split roller display and scale possible | see sketch | NBK-03/06/07/10 |
| HL | Retaining plate, centric between process connections, necessary from L > 5000 mm (alternative option HF) | see sketch | NBK-03/06/07/10/31/32/33 |
| HF | Retaining flange, centric between process connections, necessary from L > 5000 mm (alternative option HL) | see sketch | NBK-03/06/07/10/31/32/33 |
| K | Armaflex-insulation (heat co-efficient 0.025 kcal / m °C, up to 105 °C) | - | NBK-03/06/07/10 |
| Tests/certificates | | | |
| P | Radiographic examination DIN 54 111 T1 (only for V-seam) | - | NBK-03/06/07/10/31/32/33 |
| Q | Dye penetration test DIN EN 571-1 | - | NBK-03/06/07/10/31/32/33 |
| X | Pressure test with water 1.5 x PN | - | NBK-03/06/07/10/31/32/33 |
| Z | Material certification 3.1 acc. to EN 10204 | - | NBK-03/06/07/10/31/32/33 |
| MR | Material acc. to NACE MR 0103/ISO 15156 (MR0175), Declaration of conformance | - | NBK-03/06/07/10/31/32/33 |
| WV | Positive Material Identification (PMI) | - | NBK-03/06/07/10/31/32/33 |
| SF | Oil and fat free | - | NBK-03/06/07/10/31/32/33 |

¹⁾ Not possible with transmitter options H/F

²⁾ Only possible with option T (magnetostrictive sensor) or option M (reed chain with transmitter)

³⁾ Not possible with option T

Note: Please pay attention to max. permissible temperature limits of individual components.

Sketches of selected options

Option DS

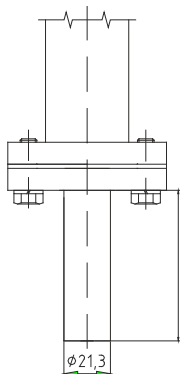

Option RF/RA

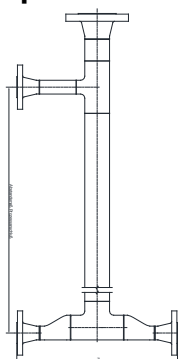

Option TT

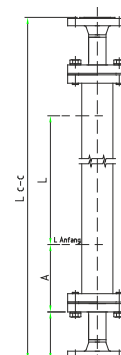

| Option | Process connection below | Dimension Z |
|--------|--------------------------|-------------|
| RF | V-flange DN25 PN40 | approx. 360 |
| RA | V-flange CI 150 1" | approx. 390 |
| RA | V-flange CI 300 1" | approx. 405 |

Option ST

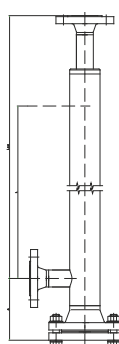
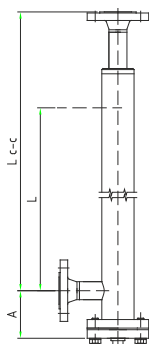

Option TS

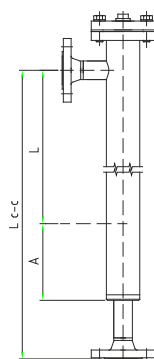

Option A

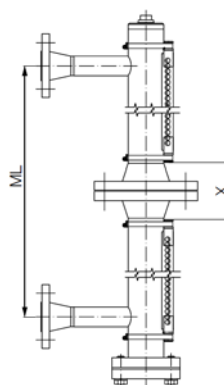

In this range, no display is possible

| Model | Dimension X |
|--------|-------------|
| NBK-03 | 92 |
| NBK-06 | 98 |
| NBK-07 | 127 |
| NBK-10 | 139 |

**Option HL
(centred to dimension L)**

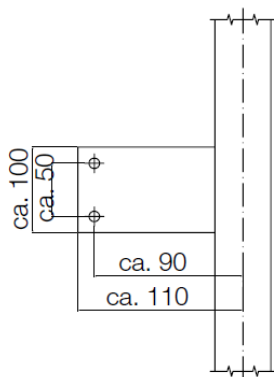

**Option HF
(centred to dimension L)**

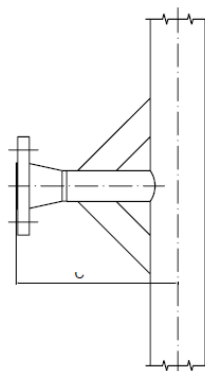

Options process connection

Option F/A

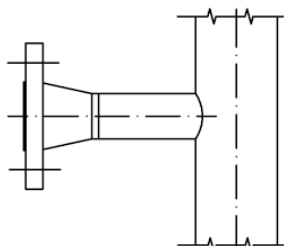

Option R/N

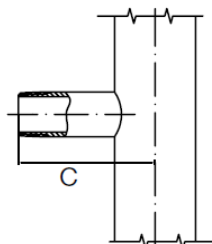

Option S

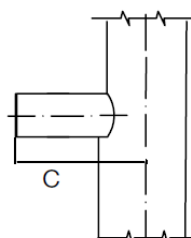

Measuring scale,
Aluminium
Option M1 – engraved scale
Option M2 – polyester foil

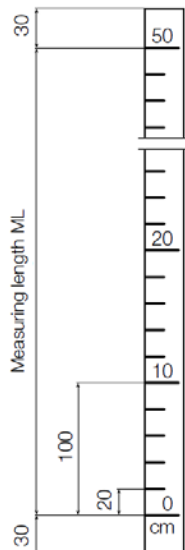

Measuring scale screen print
stainless steel carrier
(standard scope of supply with ball display)

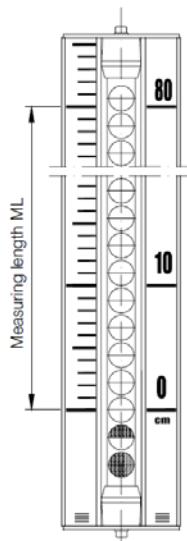

Float models (closed design)

| Model | Min. density [kg/dm ³] | Material |
|-----------------|--|-----------------|
| A | 1.0 | titanium |
| B | 0.9 | titanium |
| C | 0.8 | titanium |
| D | 0.7 | titanium |
| E | 0.6 | titanium |
| F* | 0.54 | titanium |
| V | 1.0 | stainless steel |
| W | 0.8 | stainless steel |
| H | 0.8 | CF340 |
| Interface float | Min. density difference = 150 kg/dm ³ (indicate both densities) | titanium |

*Option N not possible. Not for NBK-10, special float for special medium densities (taring) or reduced length A on request.

12. Order Codes

Order Details (Example: NBK-03 F15 00 0 A)

| Model | Nominal pressure | Connection | Nominal size | Roller/ ball indication | Sensor/ Transmitter | Medium density float | Options |
|-------------|---|---|--|---|--|--|--|
| NBK-03... | PN16/ Class 150 | F =DIN-flange A =ASME-flange R ³⁾ =R-male-thread N ³⁾ =NPT-male-thread S ⁴⁾ = welding-nipple | 15 =DN 15, 1/2" 20 =DN 20, 3/4" 25 =DN 25, 1" 32 =DN 32, 1 1/4" 40 = DN 40, 1 1/2" 50 = DN 50, 2" XX ⁸⁾ = special connection | 00 = without RP = POM-roller RK = ceramic roller KP = ball display with Plexiglas [®] sight tube KM = ball display with Makrolon [®] sight tube KF = as KM however with oil filling KG = ball display with borosilicate sight tube | 0 = without transmitter T = magnetostrictive probe/ 4...20 mA, 4-wire W = reed chain/without transmitter M = reed chain/4...20 mA, HART [®] , 2-wire A ⁹⁾ = reed chain/4...20 mA, 2-wire H = reed chain/ 4...20 mA, HART [®] , 2-wire F = reed chain/PROFIBUS [®] PA Foundation [™] Fieldbus | A = 1.0 kg/dm ³ , titanium for viscosity up to 200 cP B = 0.90 kg/dm ³ , titanium for viscosity up to 200 cP C = 0.80 kg/dm ³ , titanium for viscosity up to 200 cP D = 0.70 kg/dm ³ , titanium for viscosity up to 200 cP E = 0.60 kg/dm ³ , titanium for viscosity up to 200 cP F ⁵⁾ = 0.54kg/dm ³ , titanium for viscosity up to 200 cP V ⁵⁾ = 1.0 kg/dm ³ , stainless steel for viscosity up to 460 mm ² /s W ⁵⁾ = 0.8 kg/dm ³ , stainless steel for viscosity up to 460 mm ² /s Y = special density, titanium (specify in clear text) | 0 = without options or options as in list and description (see separate options list) |
| NBK-06... | PN 40/ Class 300 | | | | | | |
| NBK-07... | PN63/ Class 400 | | | | | | |
| NBK-10... | PN 100/Class 600 | | | | | | |
| NBK-31... | PN 160/ Class 900 | F =DIN-flange A =ASME-flange | 15 =DN 15, 1/2" | | | H = high pressure floater, CF340 viscosity up to 200 cP (medium S.G.: ≥ 0.8; specify in clear text) | |
| NBK-32... | PN 250/ Class 1500 | | 20 ⁷⁾ =DN 20, 3/4" | | | | |
| NBK-33... | PN 320 | | 25 =DN 25, 1" | | | | |
| NBK-R | Standard limit contact (bistable changeover contact) | | | | | | |
| NBK-RT200 | High-temperature limit contact max. 200°C | | | | | | |
| NBK-RT400 | High-temperature limit contact max. 400°C | | | | | | |
| NBK-RV200NO | limit contact, bistable, N/O, max. +200 °C (suitable for vessels with strong vibrations) | | | | | | |
| NBK-RV200NC | limit contact, bistable, N/C, max. +200 °C (suitable for vessels with strong vibrations) | | | | | | |
| NBK-RN200NO | limit contact, bistable, NAMUR, N/O, max. +200 °C (suitable for vessels with strong vibrations) | | | | | | |
| NBK-RN200NC | limit contact, bistable, NAMUR, N/C, max. +200 °C (suitable for vessels with strong vibrations) | | | | | | |

³⁾ Only possible with nominal diameter code 15/20/25/32 (female thread on request) ⁴⁾ Only possible with NBK-03/06 and nominal size code 15/20/25/32
⁵⁾ Only possible with NBK-03 ⁶⁾ Not possible with NBK-10 ⁷⁾ Only possible for connection A, ASME ⁸⁾ Specify in clear text
⁹⁾ Only with options AE and AC

Measuring length L, density and temperature please specify in clear text!

13. Dimensions

NBK-03/06/07/10 with roller indicator/ball display

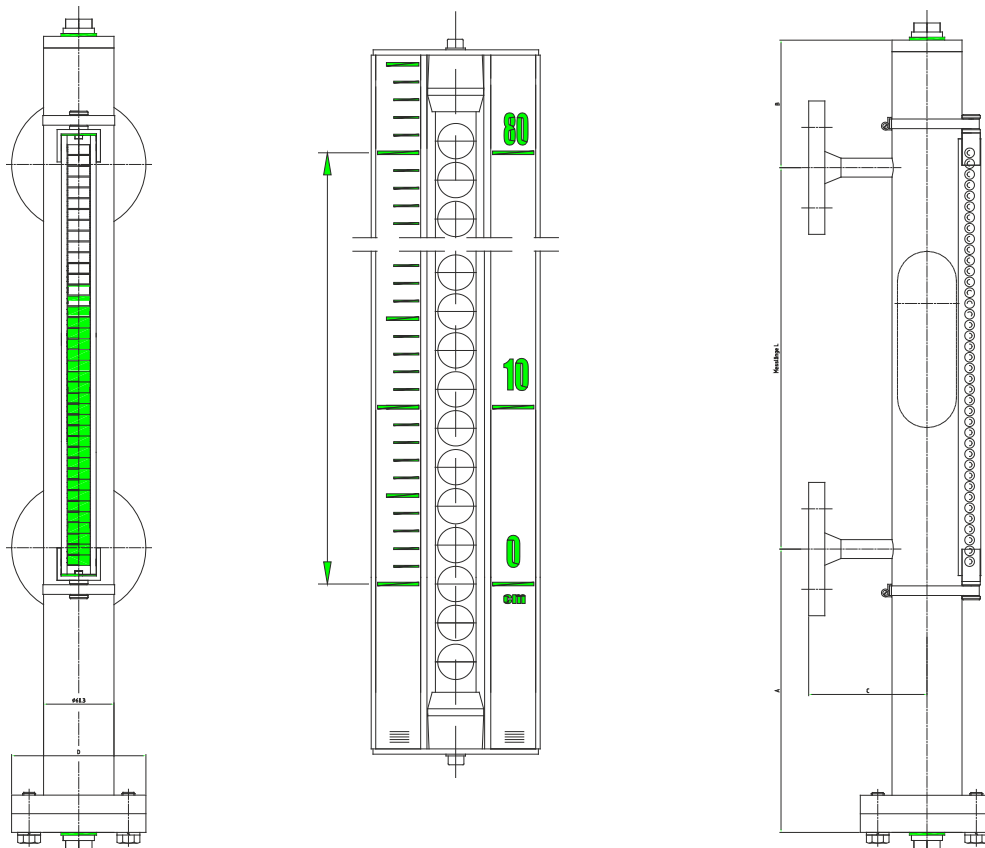

Dimension NBK

| Model | Rated pressure | ø | B | D | C | | | | | | | | | |
|--------|----------------|------|-----|-----|-------------|-----|-----|-----|-----|-----|-----|-----|-----|--|
| | | | | | x15 ... x25 | x32 | F40 | A40 | F50 | A50 | | | | |
| NBK-03 | PN 16 | 60,3 | 130 | 115 | 110 | 110 | 130 | - | 140 | - | | | | |
| | Class 150 | | | | | | - | 145 | - | 160 | | | | |
| NBK-06 | PN 40 | | | | | | 130 | - | 145 | - | | | | |
| | Class 300 | | | | | | - | 155 | - | 165 | | | | |
| NBK-07 | PN 63 | | | | | | 180 | 150 | 150 | 145 | - | 160 | - | |
| | Class 400 | | | | | | | | | - | 160 | - | 175 | |
| NBK-10 | PN 100 | | | 195 | 145 | - | 165 | | | - | | | | |
| | Class 600 | | | | - | 160 | - | | | 175 | | | | |
| NBK-31 | PN160 | | | 71 | 150 | 245 | 180 | | | | | | | |
| | Class900 | | | | | | | | | | | | | |
| NBK-32 | PN 250 | 76,1 | 170 | 265 | 210 | | | | | | | | | |
| | Class 1500 | | | | | | | | | | | | | |
| NBK-33 | PN 320 | | | | | | | | | | | | | |

NBK-10/-31/-32/-33
always without vent
plug and without
drain plug

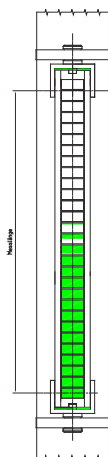

Clearance dimension A [mm]

| Model | Rated pressure | Medium density | | | | | |
|-----------|---------------------|----------------------------|---------------------------|---------------------------|---------------------------|---------------------------|-------------------------|
| | | 0.54 [kg/dm ³] | 0.6 [kg/dm ³] | 0.7 [kg/dm ³] | 0.8 [kg/dm ³] | 0.9 [kg/dm ³] | 1 [kg/dm ³] |
| NBK-03... | PN 16 / Class 150 | 320 | 320 | 320 | 320 | 320 | 210 |
| NBK-06... | PN 40 / Class 300 | 410 | 410 | 320 | 320 | 320 | 210 |
| NBK-07... | PN 63 / Class 400 | 410 | 410 | 320 | 320 | 320 | 210 |
| NBK-10... | PN 100 / Class 600 | - | 700* | 410** | 320 | 320 | 210 |
| NBK-31... | PN 160 / Class 900 | - | - | - | 540 | 415 | 345 |
| NBK-32... | PN 250 / Class 1500 | - | - | - | 540 | 415 | 345 |
| NBK-33... | PN 320 | - | - | - | 595 | 460 | 385 |

* 800 for units with thermal screening; **450 for units with thermal screening

NBK-31/32/33 with roller indicator/ball display

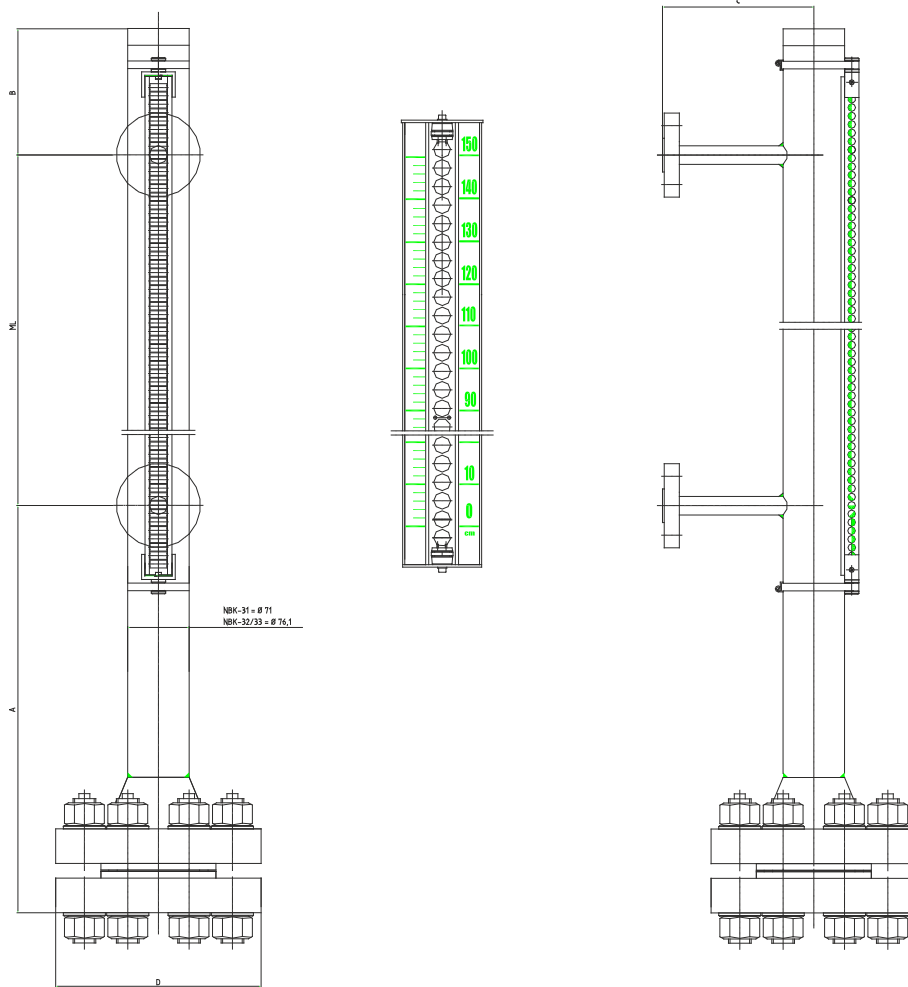

| DIN EN 1092-1:2008-09 (extract) | | | | | | | | | |
|---------------------------------|------------------|--|-------|------|------|------|------|------|------|
| PN | Material | Maximum allowable temperature TS in °C | | | | | | | |
| | | RT | 100 | 150 | 200 | 250 | 300 | 350 | 400 |
| | | Maximum allowable pressure PS in bar | | | | | | | |
| 6 | 1.4571 (15E0) | 6.0 | 6.0 | 5.8 | 5.6 | 5.3 | 5.0 | 4.8 | 4.6 |
| 16 | | 16.0 | 16.0 | 15.6 | 14.9 | 14.1 | 13.3 | 12.8 | 12.4 |
| 40 | | 40.0 | 40.0 | 39.2 | 37.3 | 35.4 | 33.3 | 32.1 | 31.2 |
| 63 | | 63.0 | 63.0 | 61.8 | 58.8 | 55.8 | 52.5 | 50.7 | 49.2 |
| 100 | | 100.0 | 100.0 | 98.0 | 93.3 | 88.5 | 83.3 | 80.4 | 78.0 |
| 160 | | 160.0 | 160.0 | | | | | | |
| 250 | | 250.0 | 250.0 | | | | | | |
| 320 | | 320.0 | 320.0 | | | | | | |

Remarks:

RT = -10 °C ... +50 °C

TS = maximum allowable temperature in °C, temperature which is defined by pressure equipment manufacturer, for which the pressure equipment is designed

PS = maximum allowable pressure, pressure which is defined by pressure equipment manufacturer, for which the plant is designed. 1.4571 (15E0) was calculated with help of creep resistance values of 100 000 h acc. to EN-Material Norms considering the safety value.

At intermediate temperatures e.g. 120 °C, a linear interpolation is to be carried out between 2 following creep resistance values, e.g. of 100 °C and 150 °C. The pressure/temperature assignment is valid for the following flange models with sizes up to DN 100 used by KOBOLD.

Model No. and nomination: 05 Blind flange, 11 Welding neck flange

NBK-... with reed chain model W

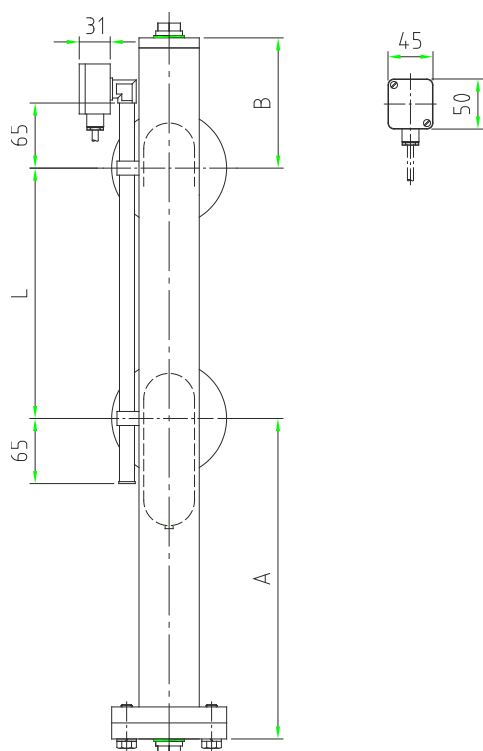

NBK-... with transmitter model M

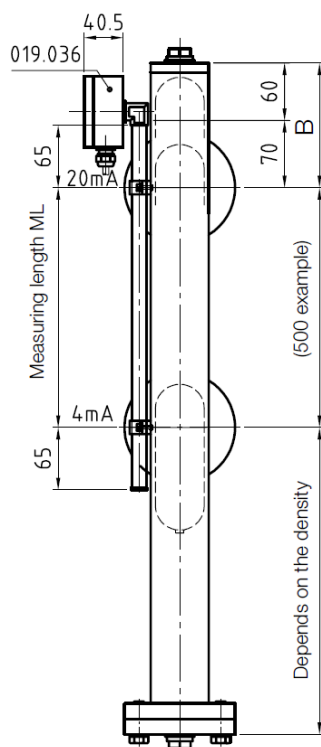

NBK-... with transmitter model T

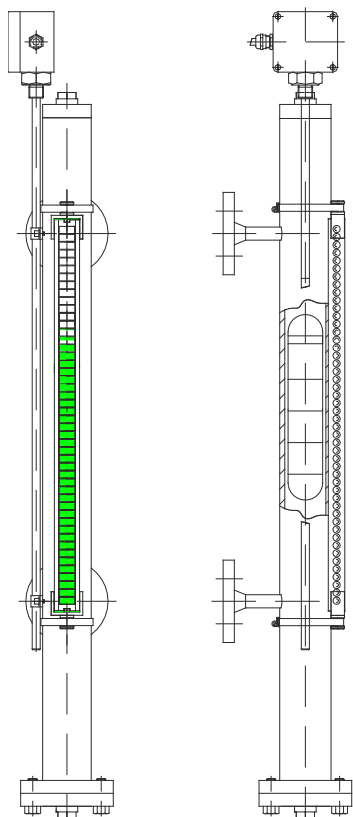

NBK-... with transmitter options H/F (not possible with options VA/VF)

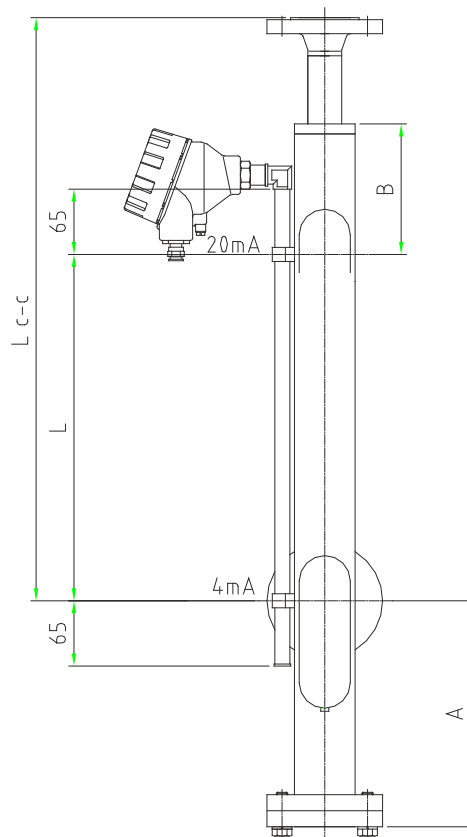

NBK-... with thermal screen option N

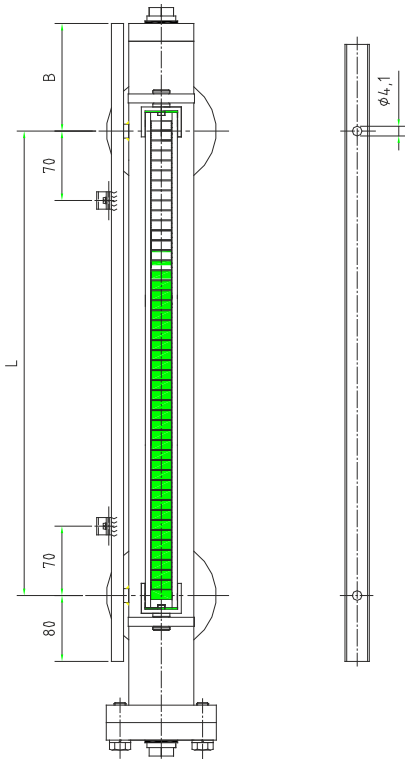

NBK-... with heating jacket option LX

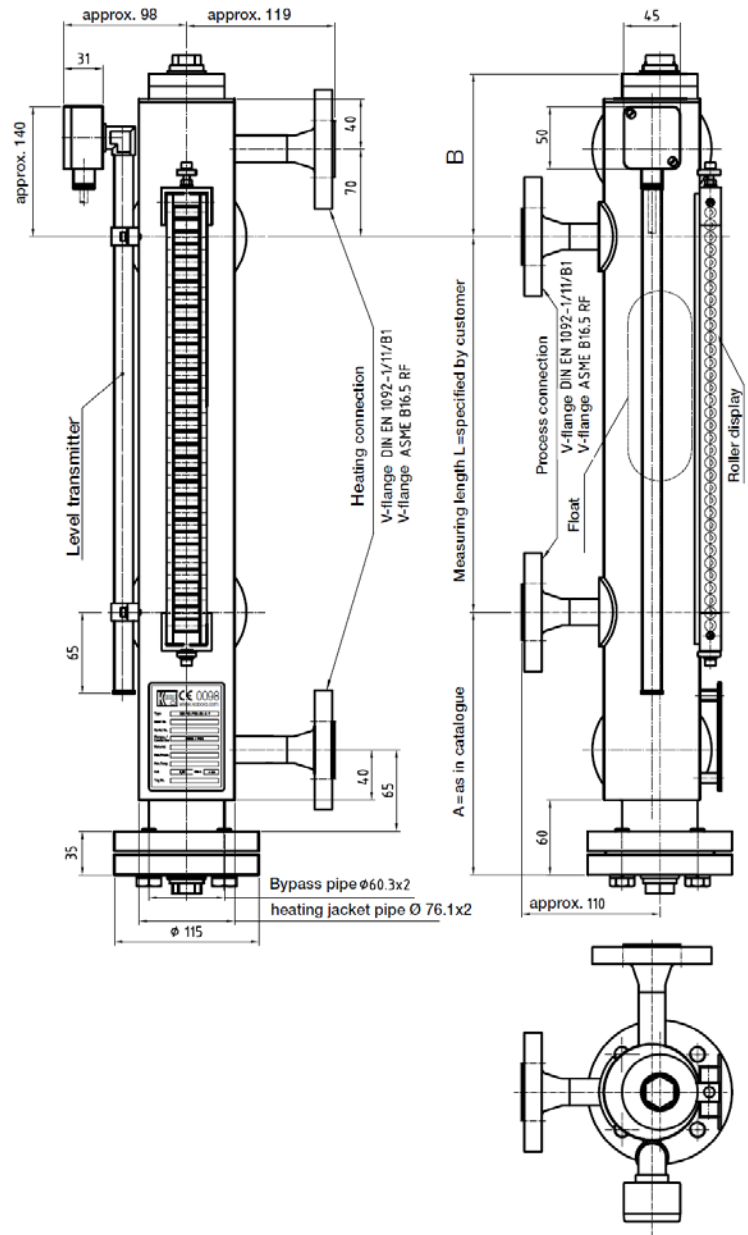

NBK-... with transmitter option MU

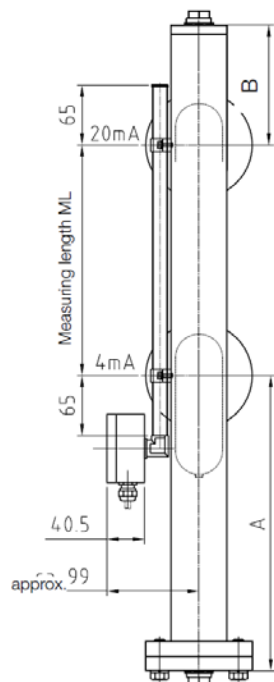

NBK-... with transmitter option MS

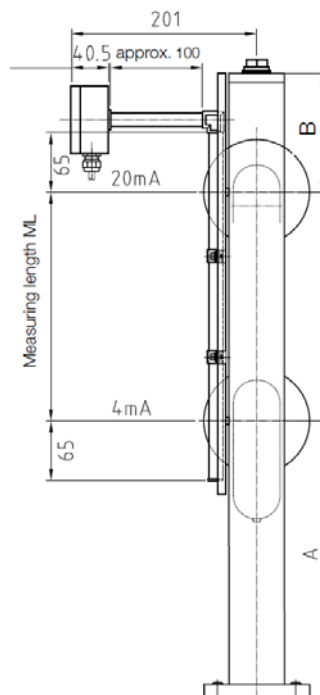

NBK-... with transmitter option MK

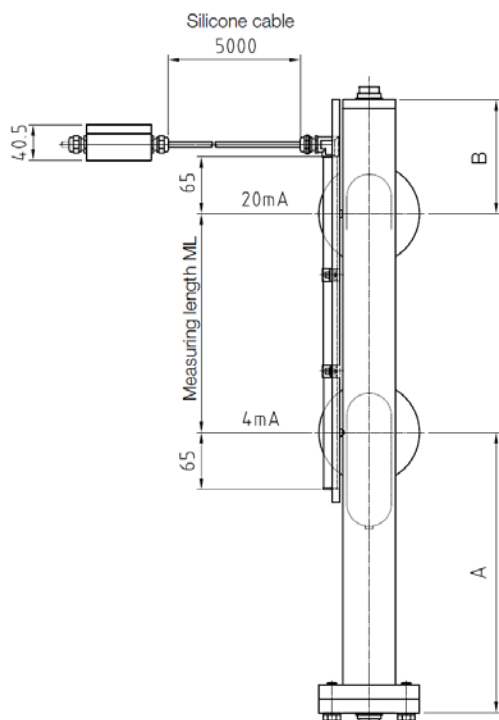

NBK-... with transmitter and display option AE/HE or AC/HC

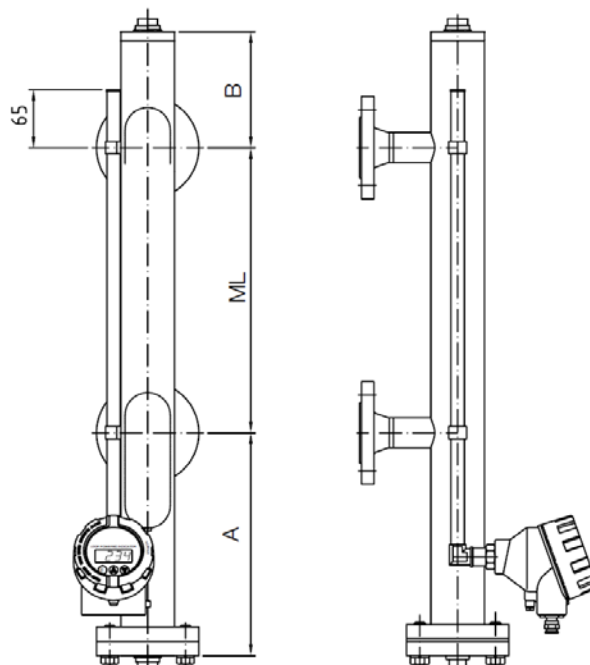

Process connection option ST

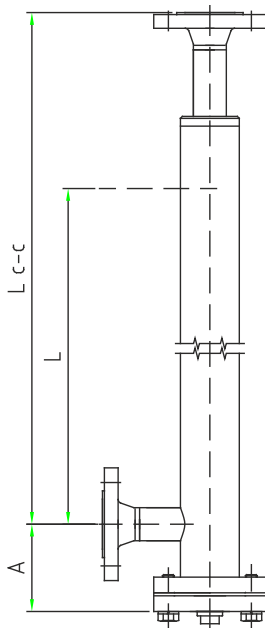

NBK-... with transmitter model M option ST

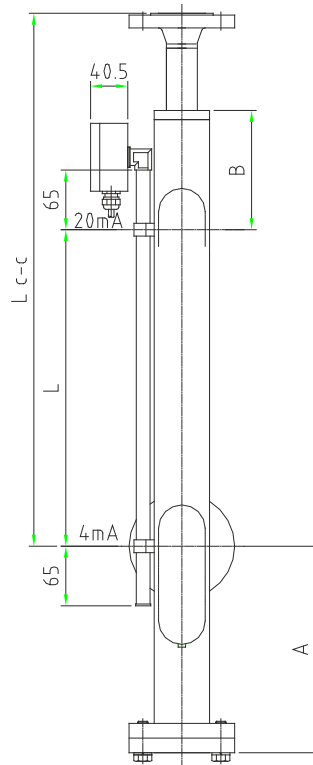

NBK-... with transmitter model H/F option ST

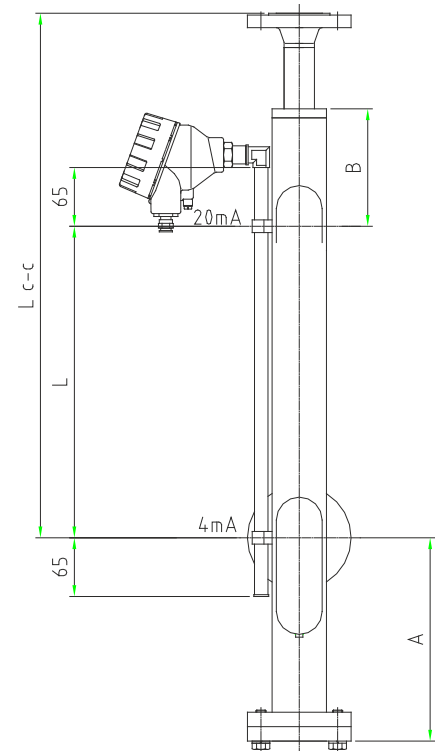

NBK-... with transmitter options MU and ST

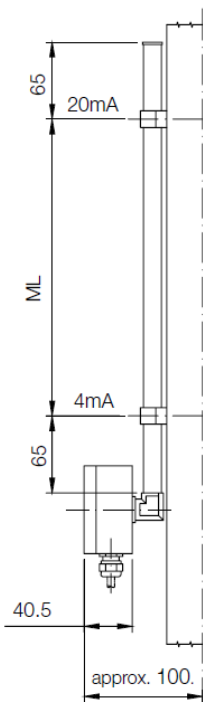

NBK-... with transmitter options MS and ST

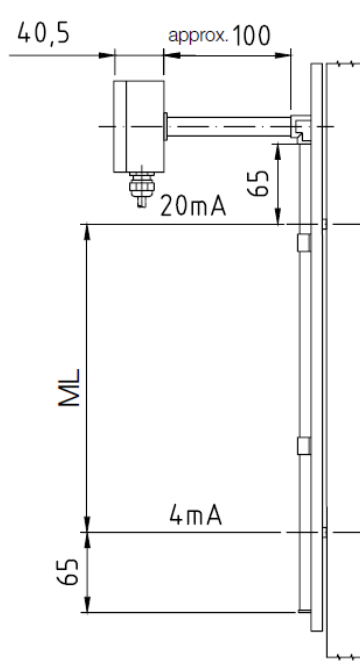

NBK-... with transmitter options MK and ST

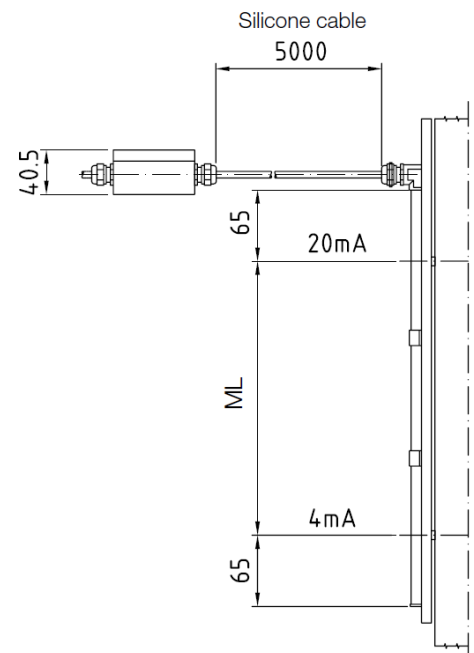

NBK-... with transmitter display options AE/HE or AC/HC and option ST

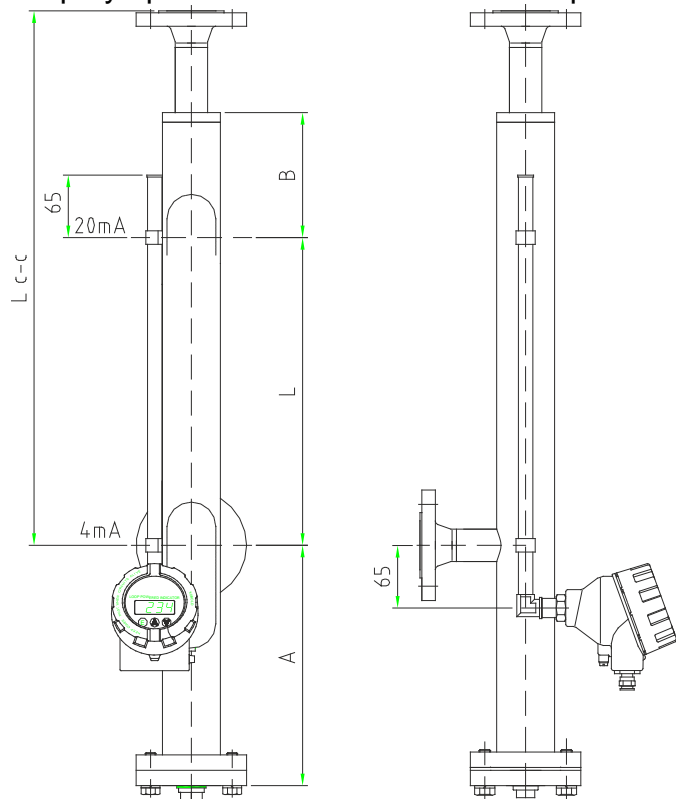

Process connection option TT

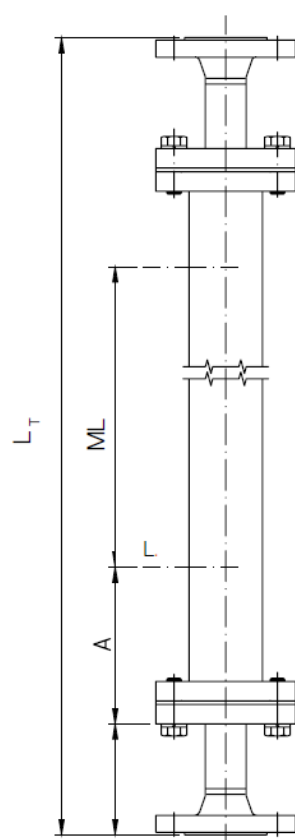

NBK-... with transmitter model M option TT

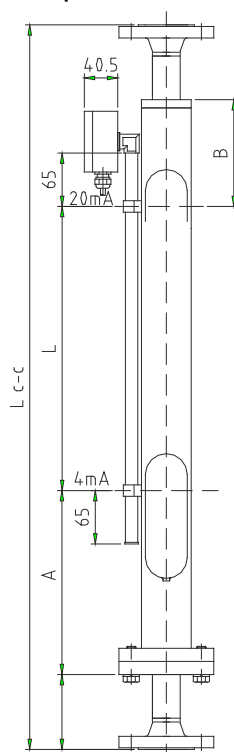

NBK-... with transmitter model H/F option TT

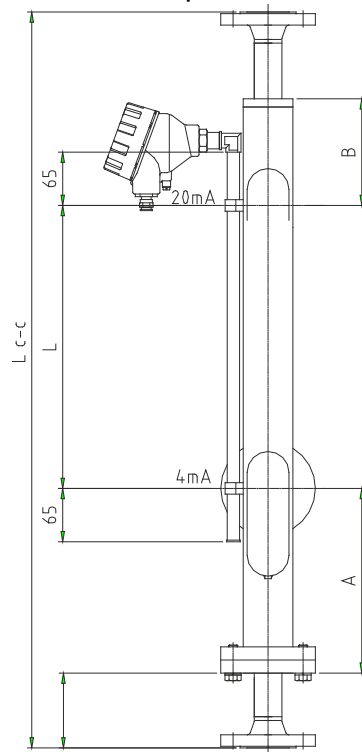

NBK-... with transmitter options MU and TT

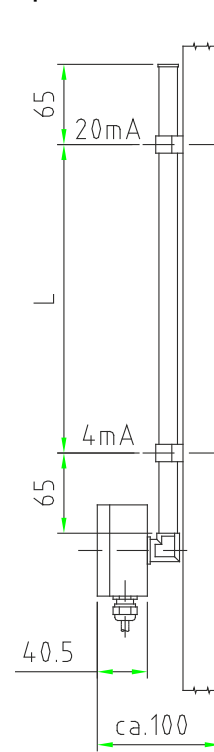

NBK-... with transmitter options MU and TT

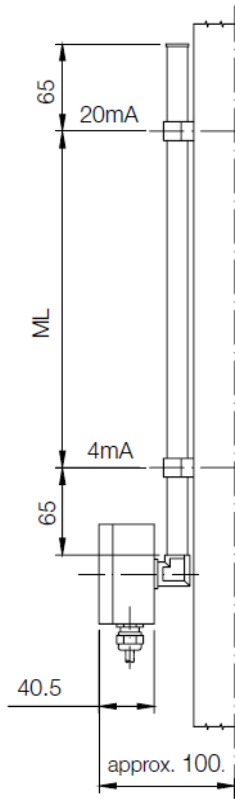

NBK-...with transmitter options MS and TT

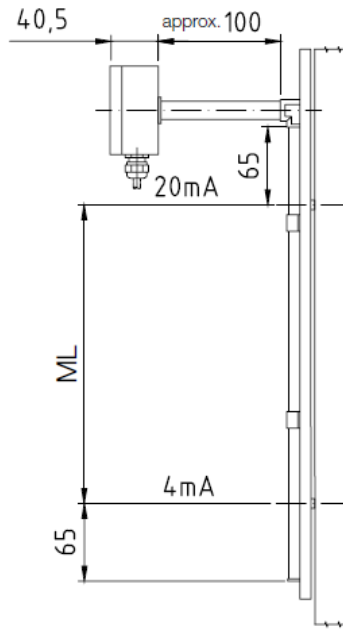

NBK-...with transmitter options MK and TT

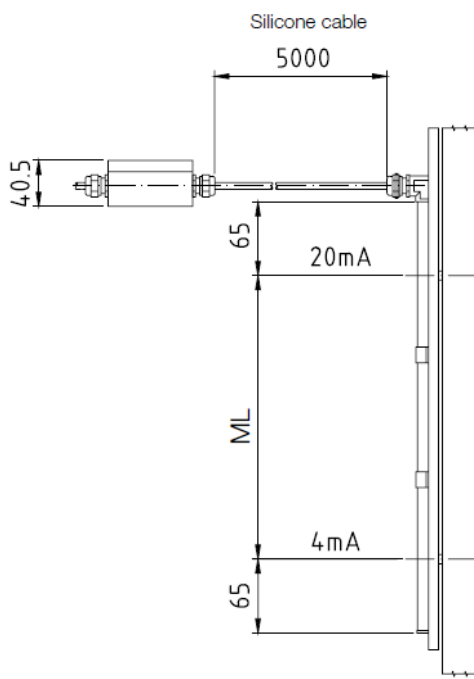

NBK-...with transmitter display options AE/HE or AC/HC and option TT

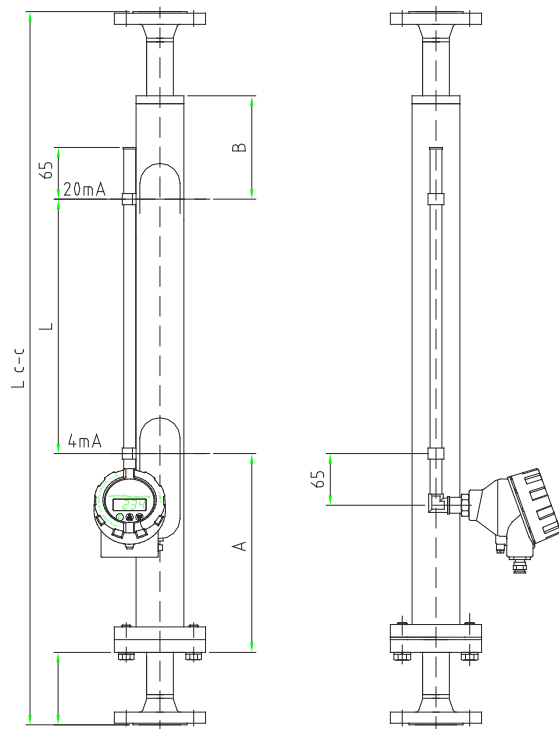

NBK-...with indicating unit ADI-1, option C

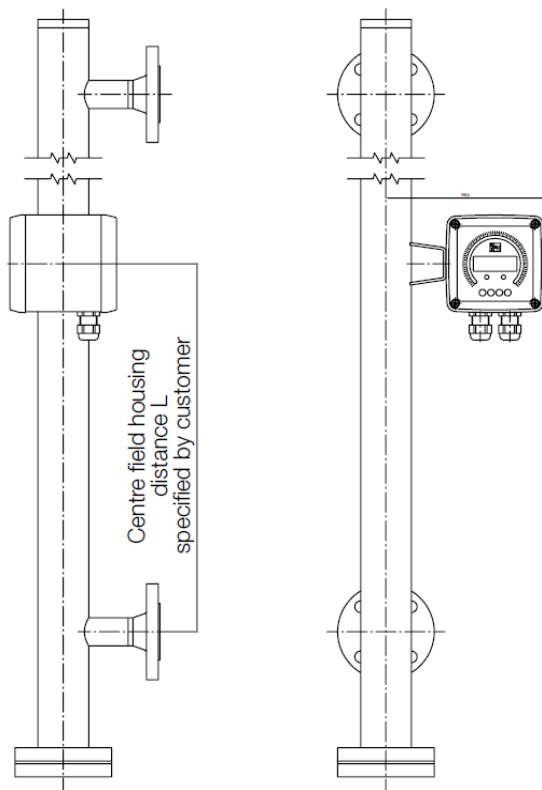

NBK-R

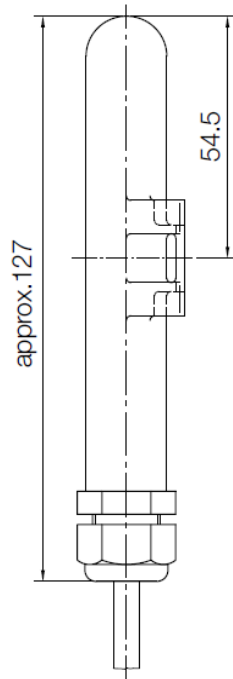

NBK-RT200

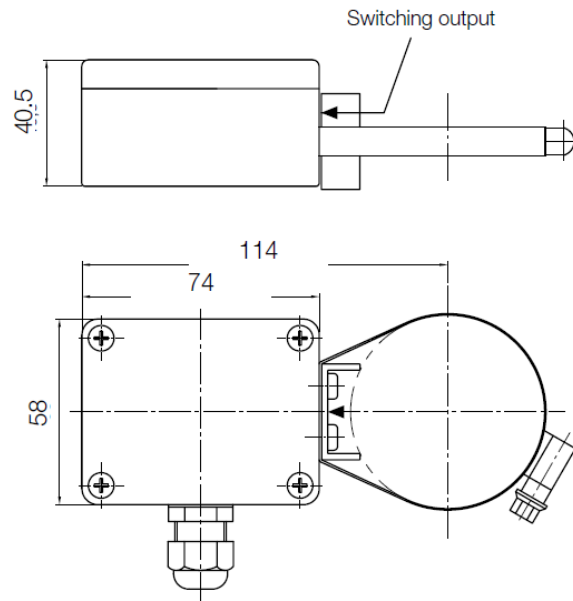

NBK-RT400

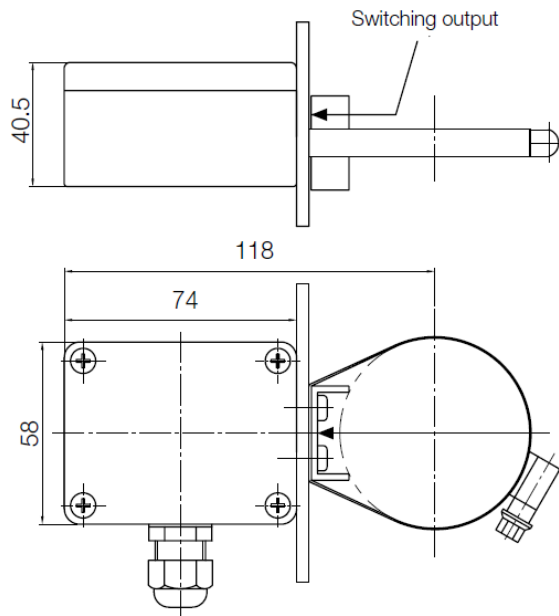

NBK-RV/RN

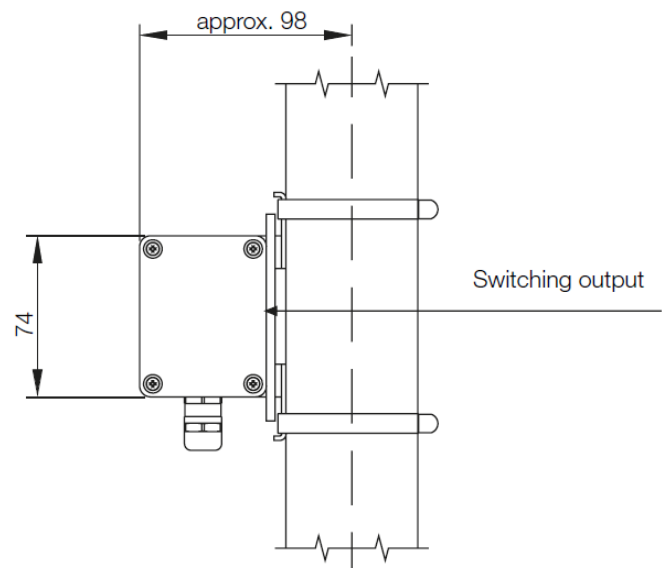

14. Disposal

Note!

- Avoid environmental damage caused by media-contaminated parts
- Dispose of the device and packaging in an environmentally friendly manner
- Comply with applicable national and international disposal regulations and environmental regulations.

Batteries

Batteries containing pollutants are marked with a sign consisting of a crossed-out garbage can and the chemical symbol (Cd, Hg, Li or Pb) of the heavy metal that is decisive for the classification as containing pollutants:

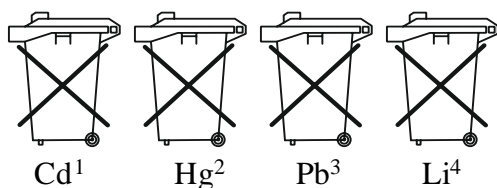

1. „Cd" stands for cadmium
2. „Hg" stands for mercury
3. „Pb" stands for lead
4. „Li" stands for lithium

Electrical and electronic equipment



15. EC Declaration of Conformance

We, KOBOLD Messring GmbH, Hofheim-Ts, Germany, declare that the limit contacts for bypass level indicator fulfil the following standards:

| Model | Pressure stage | Category as per PED | EC type examination test |
|---------------|----------------|---------------------|--------------------------|
| NBK-03 | PN 16 | III | 43 629-02 HH |
| NBK-06 | PN 40 | III | 43 630-02 HH |
| NBK-07 | PN 63 | III | 43 626-02 HH |
| NBK-10 | PN 100 | IV | 43 627-02 HH |
| NBK-31 | PN 160 | IV | PED-B-171 |
| NBK-32 | PN 250 | IV | PED-B-171 |
| NBK-33 | PN 320 | IV | PED-B-171 |

The limit contact for bypass level indicators **NBK-R**, **NBK-RT** are in conformity with the standards noted below:

EN 61010-1:2020 Safety requirements for electrical equipment for measurement, control and laboratory use - Part 1: General requirements

EN 60529:2014 Degrees of protection provided by enclosures (IP-Code)

EN IEC 63000:2018 Technical documentation for the assessment of electrical and electronic products with respect to the restriction of hazardous substances

The **bypass level indicator with remote sensor**

model NBK-...M...
model NBK-...T...
model NBK-...W...

to which this declaration relates is in conformity with the standards noted below:

EN 61326-1 :2013 Electrical equipment for measurement, control and laboratory use - EMC requirements - Part 1: General requirements

EN 60529:2014 Degrees of protection provided by enclosures (IP Code)

EN IEC 63000:2018 Technical documentation for the assessment of electrical and electronic products with respect to the restriction of hazardous substances

Also, the following EC guidelines are fulfilled:

2014/35/EU
2014/30/EU
2011/65/EU
2015/863/EU
2014/68/EU

Low Voltage Directive
EMC Directive
RoHS (category 9)
Delegated Directive (RoHS III)
PED

- Category III (IV) Diagram 1, vessel, group 1 dangerous fluids
- Module D, marking CE0575
- Notified body: DNV GL
- Certificate No. PEDD000000R

Hofheim, 18 March 2022



H. Volz
General Manager



M. Wenzel
Proxy Holder