



Bypass Level Indicators ATEX Approval



measuring
•
monitoring
•
analysing

NBK-ATEX

-03, -06, -07, -10, -31, -32, -33

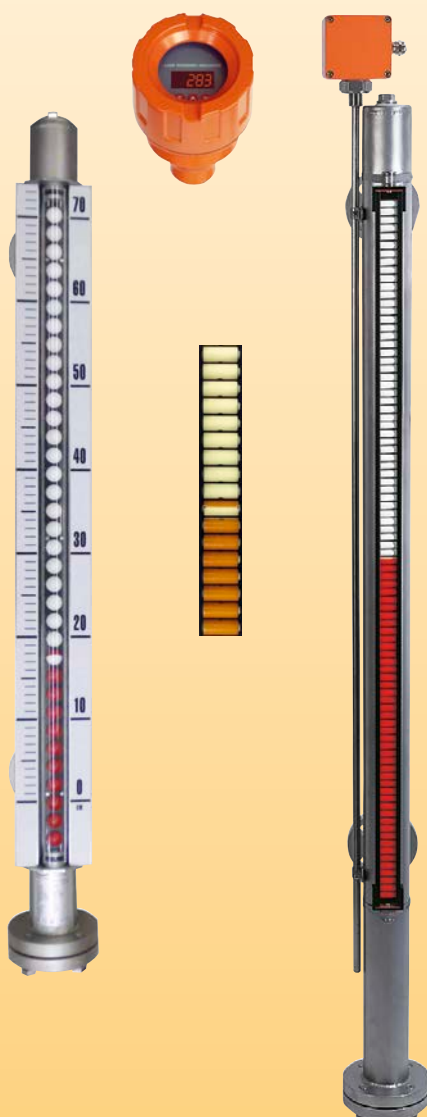

- Measuring length: single-part max. 5500 mm over 5500 mm two-part or multipart
- Pressure: max. PN320
- Temperature:
 - 40 ... +400 °C (ceramic rollers)
 - 20 ... +100 °C (POM rollers)
 - 104 ... +200 °C (ball display)
 - 60 ... +100 °C (NBK-31, -32, -33)
- Viscosity: max. 200 mm²/s standard (option: 460 mm²/s, only NBK-03)
- Connection:
 - DIN flange DN 15 ... DN 50
 - ASME flange ½" ... 2"
 - R- and NPT-threads
 - welding nipple DN 15 ... DN 32
- Material: stainless steel 1.4571
- Insensitive magnet roller or ball display without auxiliary energy
- Limit contacts
- Analogue output, HART®, Profibus® PA, Foundation™ Fieldbus®



N2

KOBOLD companies worldwide:

AUSTRALIA, AUSTRIA, BELGIUM, BULGARIA, CANADA, CHINA, CZECHIA, FRANCE, GERMANY, GREAT BRITAIN, HUNGARY, INDIA, INDONESIA, ITALY, MALAYSIA, MEXICO, NETHERLANDS, PERU, POLAND, REPUBLIC OF KOREA, RUSSIA, SPAIN, SWITZERLAND, THAILAND, TUNISIA, TURKEY, USA, VIETNAM

KOBOLD Messring GmbH
Nordring 22-24
D-65719 Hofheim/Ts.
Head Office:
+49(0)6192 299-0
+49(0)6192 23398
info.de@kobold.com
www.kobold.com



Description

Kobold bypass level indicators are used for continuous measurement, display and monitoring of liquid levels. The bypass tube is attached onto the side wall of the vessel.

According to the law of communicating tubes the level in the bypass tube equals the level in the vessel. A float with embedded circular magnets in the bypass tube follows the liquid level and transfers it in a non-contacting manner to a display fitted outside the tube or to a monitoring device.

The following indication and monitoring devices are available:

ATEX version

The bypass level indicators are supplied with ATEX approval. Limit contacts and an immersible magnetic probe (reed contact chain) with ATEX approval are available for level measurement and monitoring. The electrical components have their own ATEX-certification.

ATEX approval:

Bypass-level indicator: II 1/2G Ex h IIC T5...T1 Ga/Gb
-20 °C ≤ T_a ≤ +80 °C

or

II 1G/2D Ex h IIC/IIIC
T4...T1/T 130 °C... 445 °C Ga/Db
-20 °C ≤ T_a ≤ +80 °C

or

II 1/3G Ex h IIC T4...T1 Ga/Gc
-20 °C ≤ T_a ≤ +80 °C

or

II 1G/3D Ex h IIC/IIIC
T4...T1/T 130 °C... 445 °C Ga/Dc
-20 °C ≤ T_a ≤ +80 °C

Limit contact NBK-RA: II 2D Ex mb IIIC IP67 T 105 °C Db

Reed contact

resistance chain: II 1GD Ex ia IIC T6 Ga
 II 1/2G Exd IIC T6 Ga/Gb
 II 1/2D Ex tb IIIC T85 °C Da/Db

Magnetic roller/ball indicator

As the float passes by, the red/white* rollers/balls are rotated in succession by 180° around their own axes. The rollers/balls change from white to red as the level rises and from red to white as the level falls. The advantage of ball display is the higher protection category, good visibility of 180° and higher vibration resistance with filled version. The level in a tank or a mixer is continuously displayed as a red column, even when the power fails.

* ceramic rollers in orange/beige

Transmitter

To remotely transmit the level a transmitter with a immersible magnetic probe (chain of resistors) or a magnetostrictive transducer can be mounted outside the bypass tube. A continuous standard signal of 4-20 mA is generated by means of a fitted transmitter. (This standard signal can then be displayed on analogue or digital indicating devices. Optionally, HART®, Profibus®-PA or Foundation™ Fieldbus®. Communication protocols are possible.)

Limit contacts

One or more immersible reed contacts for limit-value acquisition or also for level control can be secured to the bypass tube.

Applications

- Storage tanks
- Agitator vessel
- Tanks on ships
- Water tanks

Technical Details

Process connection: flange DINEN1092-1 type 11, forme B
DN 15, DN 20, DN 25, DN 32, DN 40, DN 50,
flange ASME B 16.5 RF-2009 ½", ¾", 1", 1¼", 1½", 2"
R-thread DIN EN 10226-1 ½", ¾", 1", 1¼"
NPT ANSI/ASME B1.20.1 ½", ¾", 1", 1¼"

Bypass tube: Ø 60.3 mm, 1.4571 (NBK-03/.../10)
Ø 71.0 mm, 1.4571 (NBK-31)
Ø 76.1 mm, 1.4571 (NBK-32/33)

NBK-03/06/07: flat gasket: <200 °C; PTFE, ≥200 °C, Klinger SIL®

NBK-10: reinforced graphite
NBK-31/32/33: RTJ-seal

Operating pressure: PN 16/40/63/100/160/250/320
Operat. temperature: -40 ... +400 °C (ceramic rollers)

-20 ... +100 °C (POM rollers)
-104 ... +200 °C (ball display)
-60 ... +100 °C (NBK-31, -32, -33)

Viscosity: max. 200 mm²/s standard
(Option: up to max. 460 mm²/s for NBK-03)

Max. meas. length: up to 5500 mm single-part;
longer two-part or multipart

Overall length: see dimension drawing

Roller display model RP (max. length 5500 mm)

Material roller: POM
Display glass: PMMA
Carrier frame material: aluminium, black anodised
Operat. temperature: -20 ... 100 °C
Protection: IP 54
Approval: ATEX



Technical Details (continuation)

Roller display model RK (max. length 5500 mm)

Material roller:	Ceramic
Display glass:	borosilicate glass
Carrier frame material:	aluminium, black anodised
Operat. temperature:	-40... 400 °C
Protection:	IP54
Approval:	ATEX

Ball display model KP (max. length 3800 mm one-piece)*

Material ball:	PA
Sight tube:	PMMA
Sealing plug:	aluminium
Seal:	NBR
Ball support rail:	aluminium, black anodised
Carrier frame:	stainless steel 1.4301
Scale:	PVC, stainless steel 1.4301 (option MV)
Medium temperature:	-20... +80 °C
Ambient temperature:	-20... +80 °C
Protection:	IP66

Ball display model KM (max. length 3800 mm one-piece)*

Material ball:	PA - high temperature strength
Sight tube:	PC
Sealing plug:	aluminium
Seal:	FKM
Ball support rail:	aluminium, black anodised
Carrier frame:	stainless steel 1.4301
Scale:	PVC, stainless steel 1.4301 (option MV)
Medium temperature:	-60... +120 °C
Ambient temperature:	-20... +80 °C
Protection:	IP66

Ball display model KF (max. length 3800 mm one-piece)*

Filling:	silicone oil
Material ball:	PA - high temperature strength
Sight tube:	PC
Sealing plug:	stainless steel 1.4571
Seal:	FKM
Ball support rail:	aluminium, black anodised
Carrier frame:	stainless steel 1.4301
Scale:	Hart-PVC, stainless steel 1.4301 (option MV)
Medium temperature:	-104... +120 °C
Ambient temperature:	-20... +80 °C
Protection:	IP66

Ball display model KG (max. length 3000 mm one-piece)*

Material ball:	PA - high temperature strength
Sight tube:	borosilicate glass
Sealing plug:	stainless steel 1.4571
Seal:	FKM
Ball support rail:	aluminium, black anodised
Carrier frame:	stainless steel 1.4301
Scale:	stainless steel 1.4301
Medium temperature:	-20... +200 °C
Ambient temperature:	-20... +200 °C
Protection:	IP66

* In case of multi port design, a display length from 32 mm is not readable

ATEX approval

ATEX limit contact, model NBK-RA

Contact operation:	bistable changeover contact encapsulated
Switching hysteresis:	approximately 15 mm
Max. switch. capacity:	45 VA, 230 V _{AC/DC} , 0.6 A
Temperature class:	T5/T6
Max. ambient temp.:	70 °C / 85 °C
Connection:	3 m PVC-cable
Housing:	metallic, cast (GD-ZN Al 4 Cu1)
Protection:	IP67
ATEX marking:	II 2G Ex mb IIC T5/T6 Gb II 2D Ex mb IIIc IP67 T 105 °C Db

ATEX reed contact resistor chain model: ...2....

In protection type intrinsically safe Ex ia IIC only for connection to a certified intrinsically safe current loop with the following maximum values:

Total resistance:	0.7... 7 kΩ
Max. voltage:	U _i = 24 V
Max. capacity:	P _i = 1.2 W
Temperature class:	T6
Resolution:	10 mm
Housing:	aluminium pressure-cast
Protection:	IP65
ATEX marking:	II 1GD Ex ia IIC T6 Ga

ATEX immersible reed contact resistor chain options E/R/B only in connection with an external intrinsically safe power supply

Option E

Transmitter model: 5333D

Common specifications:

Power supply:	8.0... 35 V _{DC}
Communication interface:	Loop Link 5905
Linear resistance input:	0... 10 kΩ

Technical Details (continuation)

Current Output:

Signal range:	4 ... 20 mA
Min. signal range:	16 mA
Updating time:	135 ms
Load resistance:	$\leq (V_{\text{supply}} - 8V) / 0.023 [\Omega]$

Sensor error detection:

Programmable:	3.5 ... 23 mA
NAMUR NE43 upscale:	23 mA (factory default)
NAMUR NE43 Downscale:	3.5 mA
Data for intrinsically safe current circuit:	see instruction manual

U_i :	28 V _{DC}
I_i :	120 mA _{DC}
P_i :	0.84 W
L_i :	10 μ H
C_i :	1.0 nF

ATEX approval transmitter:

KEMA 03ATEX1535:	 II 1G Ex ia IIC T4 or T6
	 II 1D Ex iaD

Max. ambient temp. for T1...T4:	85 °C
Max. ambient temp. for T5 and T6:	60 °C
Applicable in zone:	0, 1, 2, 20, 21 or 22
Medium temperature:	-40 ... +120 °C (with option N up to 250 °C)
Ambient temperature:	-40 ... +80 °C
Resolution:	10 mm
Housing:	aluminium pressure-cast
Protection:	IP 66

Option R

Transmitter model: 5337D

Common specifications:

Power supply:	8.0 ... 35 V _{DC}
Communication interface:	Loop Link 5905A and HART®
Linear resistance input:	0 ... 7 k Ω



Current Output:

Signal range:	4 ... 20 mA
Min. signal range:	16 mA
Updating time:	440 ms
Load resistance:	$\leq (V_{\text{supply}} - 8V) / 0.023 [\Omega]$

Sensor error detection:

Programmable:	3.5 ... 23 mA 23 mA (factory default)
Data for intrinsically safe current circuit:	see instruction manual

ATEX approval transmitter:

KEMA 03 ATEX 1537:	 II 1G Ex ia IIC T6 or T4 Ga
	 II 1D Ex ia IIIC Da
Max. ambient temp. for T1...T4:	85 °C
Max. ambient temp. for T5 or T6:	60 °C
Applicable in zone:	0, 1, 2, 20, 21 or 22
Medium temperature:	-40 ... +120 °C (with option N up to +250 °C)
Ambient temperature:	-40 ... +80 °C
Resolution:	10 mm
Housing:	aluminium pressure-cast
Protection:	IP 66

Option B

Transmitter model: 5350B

Common specifications:

Power supply:	9 ... 32 V _{DC}
Consumption:	< 11 mA
Isolation voltage, test / operation:	1.5 kV _{AC} / 50 V _{AC}
Signal / noise ratio:	min. 60 dB
Response time (programmable):	1 ... 60 s
Updating time:	< 400 ms
Dimensions:	\varnothing 44 x 20.2 mm
Linear resistance input:	0 ... 10 k Ω

Output:



Foundation™ Fieldbus® connection:

Foundation™	
Fieldbus® version:	ITK 4.6
Foundation™	
Fieldbus® capability:	Basic or LAS
Foundation™	
Fieldb. function blocks:	2 analogue and 1 PID

Profibus® PA connection:

Profibus® PA	
protocol standard:	EN 50170 vol. 2
Profibus® PA	
function blocks:	2 analogue
Data for intrinsically safe current circuit:	see instruction manual

ATEX approval transmitter:

KEMA 02ATEX1318:	 II 1 G Ex ia IIC T4 ... T6 or
	 II 2 (1) G Ex ib [ia] IIC T4 ... T6
	 II 1 D Ex iaD
Applicable in zone:	0, 1, 2, 20, 21 or 22
Medium temperature:	-40 ... +120 °C (with option N up to +250 °C)
Ambient temperature:	-40 ... +80 °C
Resolution:	10 mm
Housing:	aluminium pressure-cast
Protection:	IP 66



Technical Details (continuation)

Option 4

Total resistance: 0.7... 7 kΩ
 Max. voltage: U: 24 V_{DC}
 Max. capacity: 125 mW
 Temperature class: T6
 Resolution: 10 mm
 Housing: aluminium pressure-cast
 Protection: IP65
 Explosion proof version: II 1/2G Ex d IIC T6 Ga/Gb

Option L

Transmitter model: 5333D

Common specifications:

Power supply: 8.0... 35 V_{DC}
 Communication interface: Loop Link 5905
 Linear resistance input: 0... 10 kΩ

Current Output:

Signal range: 4... 20 mA
 Min. signal range: 16 mA
 Updating time: 135 ms
 Load resistance: $\leq (V_{\text{supply}} - 8V) / 0.023 [\Omega]$

Sensor error detection:

Programmable: 3.5... 23 mA
 NAMUR NE43 upscale: 23 mA (factory default)
 NAMUR NE43 downscale: 3.5 mA

LED or LCD display (options LE/LC):

Power supply: loop powered
 Voltage: LED 3.3 V at 4 mA
 3.7 V at 20 mA
 LCD max. 2.5 V
 Medium temperature: -40... +120 °C (with option N up to 250 °C)
 Ambient temperature: -40... +80 °C
 Resolution: 10 mm
 Housing: aluminium pressure-cast
 Protection: IP66

Option K

Transmitter model: 5337D

Common specifications:

Power supply: 8.0... 35 V_{DC}
 Communication interface: Loop Link 5905A and HART®
 Linear resistance input: 0... 7 kΩ

Current Output:

Signal range: 4... 20 mA
 Min. signal range: 16 mA
 Updating time: 440 ms
 Load resistance: $\leq (V_{\text{supply}} - 8) / 0.023 [\Omega]$

Sensor error detection:

Programmable: 3.5... 23 mA
 23 mA (factory default)

LED or LCD display (Options KE/KC):

Power supply: Loop powered
 Voltage drop: LED 3.3 V at 4 mA
 3.7 V at 20 mA
 LCD max. 2.5V
 Medium temperature: -40... +120 °C (with option N up to 250 °C)
 Ambient temperature: -40... +80 °C
 Resolution: 10 mm
 Housing: aluminium pressure-cast
 Protection: IP66

Option N

Transmitter model: 5350A

Common specifications:

Power supply: 9... 32 V_{DC}
 Consumption: <11 mA
 Isolation voltage, test / operation: 1.5 kV_{AC} / 50 V_{AC}
 Signal / noise ratio: min. 60 dB
 Response time (programmable): 1... 60 s
 Updating time: <400 ms
 Dimensions: Ø 44 x 20.2 mm
 Linear resistance input: 0... 10 kΩ

Output:

Foundation™ Fieldbus® connection:

Foundation™
 Fieldbus® version: ITK 4.6
 Foundation™
 Fieldbus® capability: Basic or LAS
 Foundation™
 Fieldb. function blocks: 2 analogue and 1 PID

Profibus® PA connection:



Profibus® PA
 protocol standard: EN 50170 vol. 2
 Profibus® PA
 function blocks: 2 analogue
 Medium temperature: -40... +120 °C (with option N up to 250 °C)
 Ambient temperature: -40... +80 °C
 Resolution: 10 mm
 Housing: aluminium pressure-cast
 Protection: IP66



Options for NBK with ATEX Approval

Code	Description	Sketch/picture	Availability
Top bypass tube connections			
V0	Without vent plug		NBK-03/06/07 NBK-10/31/32/33 standard
VG	With vent plug G 1/2		NBK-10 NBK-03/06/07, standard
VF ¹⁾	Flange connection DN50 (pressure rating as process flange)		NBK-03/06/07/10
VA ¹⁾	Flange connection 2" ASME (pressure rating as process flange)		NBK-03/06/07/10
V4	Vent flange DN15, stainless steel 1.4571 (pressure rating as process flange)		NBK-03/06
V5	Vent flange DN20, stainless steel 1.4571 (pressure rating as process flange)		NBK-03/06
V6	Vent flange DN25, stainless steel 1.4571 (pressure rating as process flange)		NBK-03/06
V7	Vent flange 1/2" ASME, stainless steel 1.4571 (316Ti) (pressure rating as process flange)		NBK-03/06
V8	Vent flange 3/4" ASME, stainless steel 1.4571 (316Ti) (pressure rating as process flange)		NBK-03/06
V9	Vent flange 1" ASME, stainless steel 1.4571 (316Ti) (pressure rating as process flange)		NBK-03/06
V2	Vent valve NAD-MMN15, 1/2" NPT, stainless steel 316Ti, max. temp.: +120°C		NBK-03/06
V3	Vent valve NAD-MMR15, G 1/2, stainless steel 1.4571, max. temp.: +120°C		NBK-03/06
¹⁾ Not possible with transmitter options E/R/B			
Bottom bypass tube connections			
D0	Without drain plug		NBK-03/06/07 NBK-10/31/32/33 standard
DG	With drain plug G 1/2	NBK-03/06 NBK-07/10	NBK-10 NBK-03/06/07, standard
DF	Flange connection DN50 (pressure rating as process flange), with drain plug G 1/2		NBK-03/06
DA	Flange connection 2" ASME (pressure rating as process flange), with drain plug 1/2" NPT		NBK-03/06
DC	Flange connection DN50 (pressure rating as process flange), without drain plug		NBK-03/06/07
DD	Flange connection 2" ASME (pressure rating as process flange), without drain plug		NBK-03/06/07
EF	Drain flange DN15, stainless steel 1.4571 (pressure rating as process flange)		NBK-03/06
E5	Drain flange DN20, stainless steel 1.4571 (pressure rating as process flange)		NBK-03/06
E6	Drain flange DN25, stainless steel 1.4571 (pressure rating as process flange)		NBK-03/06
E7	Drain flange 1/2" ASME, stainless steel 1.4571 (316Ti) (pressure rating as process flange)		NBK-03/06
E8	Drain flange 3/4" ASME, stainless steel 1.4571 (316Ti) (pressure rating as process flange)		NBK-03/06
E9	Drain flange 1" ASME, stainless steel 1.4571 (316Ti) (pressure rating as process flange)		NBK-03/06

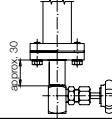
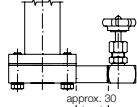
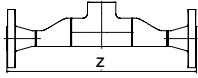
Options (continuation)

Code	Description	Sketch/picture	Availability
F1	Drain valve NAD-MMR15, G½, stainless steel 1.4571, max. temp.: +120°C		NBK-03/06
F2	Drain valve NAD-MMN15, ½" NPT, stainless steel 316Ti, max. temp.: +120°C		NBK-03/06
DS	Drain socket DN15	see sketch	NBK-03
D2	Drain valve NAD-MMN15, ½" NPT, horizontally mounted, stainless steel 1.4571 (316Ti), max. temp.: +120°C		NBK-03/06
D3	Drain valve NAD-MMR15, G ½, horizontally mounted, stainless steel 1.4571 (316Ti), max. temp.: +120°C		NBK-03/06
RF ¹⁾	Dead space free version DN25, stainless steel 1.4571 (pressure rating as process flange)		NBK-06
RA ¹⁾	Dead space free version 1" ASME, stainless steel 31.4571 (316Ti) (pressure rating as process flange)		NBK-03/06
Process connection options			
ST	1 x process connection side, 1 process connection vertical on top	see sketch	NBK-03/06/07/10
TS	1 x process connection side, 1 process connection vertical at bottom	see sketch	NBK-03/06/07/10
TT	2 x process connection vertical, up to DN25 or 1" ASME	see sketch	NBK-03/06/07/10
Scales			
(Ball displays are always delivered with scales, see technical data/ sketch for resolution)			
MV	Scale made of stainless steel 1.4301 (only with ball display model KP/KM/KF, standard with model KG)	see sketch	NBK-03/06/07/10/31/32/33
M1	Measuring scale, medium temperature -40°C ... +400°C, engraved scale made of aluminium	see sketch	NBK-03/06/07/10/31/32/33
M2	Measuring scale, medium temperature -40°C ... +150°C, scale backing made of aluminium with polyester foil	see sketch	NBK-03/06/07/10/31/32/33
Thermal screening			
N	Thermal screening for sensor	see sketch	NBK-03/06/07/10/31/32/33
Electrical outputs			
MU ²⁾	Option with connection box at bottom, for easy access to connection box		NBK-03/06/07/10
MS ²⁾	Option and connection box at 100 mm distance, max. medium temperature = +300°C (Thermal screening option N mandatory with this option)		NBK-03/06/07/10
Display options			
LE	Aluminium die-cast housing, LED digital display, connection box at bottom (only in combination with transmitter option L)		NBK-03/06/07/10
LC	Aluminium die-cast housing, LCD digital display, connection box at bottom (only in combination with transmitter option L)	as LE, however with LCD display	NBK-03/06/07/10
KE	Aluminium die-cast housing, LED digital display, connection box at bottom (only in combination with transmitter option K)		NBK-03/06/07/10
KC	Aluminium die-cast housing, LCD digital display, connection box at bottom (only in combination with transmitter option K)	as KE, however with LCD display	NBK-03/06/07/10

¹⁾ On request

²⁾ Only in addition with optional sensor/transmitter



Options (continuation)

Code	Description	Sketch/picture	Availability
Additional options			
A	Connection flange for 2-part version (not possible with sensor), split roller display and scale possible.	see sketch	NBK-03/06/07/10
HL	Retaining plate, centric between process connections, necessary from L > 5000 mm (alternative option HF)	see sketch	NBK-03/06/07/10/31/32/33
HF	Retaining flange, centric between process connections, necessary from L > 5000 mm (alternative option HL)	see sketch	NBK-03/06/07/10/31/32/33
Tests / certificates			
P	Radiographic examination DIN 54 111 T1 (only for V-seam)	-	NBK-03/06/07/10/31/32/33
Q	Dye penetration test DIN EN 571-1	-	NBK-03/06/07/10/31/32/33
X	Pressure test with water 1.5 x PN	-	NBK-03/06/07/10/31/32/33
Z	Material certificate 3.1 acc. to EN 10204	-	NBK-03/06/07/10/31/32/33
MR	Material acc. to NACE MR 0103/ISO15156 (MR0175), Declaration of conformance	-	NBK-03/06/07/10/31/32/33
WV	Positive Material Identification (PMI)	-	NBK-03/06/07/10/31/32/33
SF	Oil and fat free	-	NBK-03/06/07/10/31/32/33

Note: Please pay attention to max. permissible temperature limits of individual components!

Sketches of selected options

Option DS

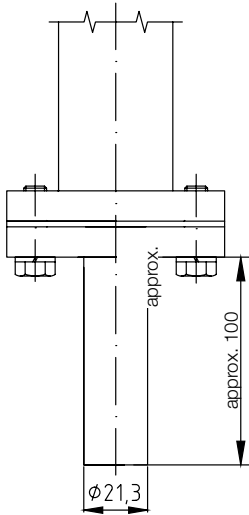

Option RF/RA

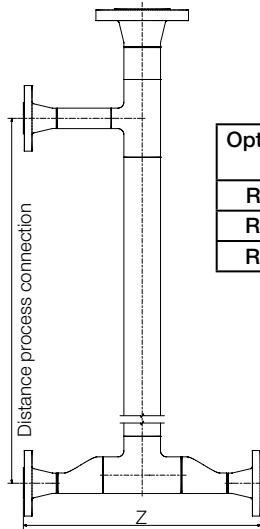

Option	Process connection below	Dimension Z
RF	V-flange DN25 PN40	approx. 360
RA	V-flange CI 150 1"	approx. 390
RA	V-flange CI 300 1"	approx. 405

Option TT

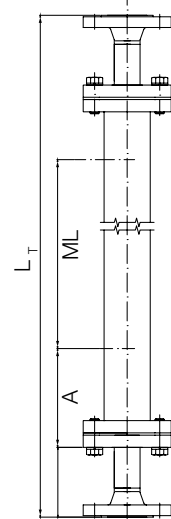

Option ST

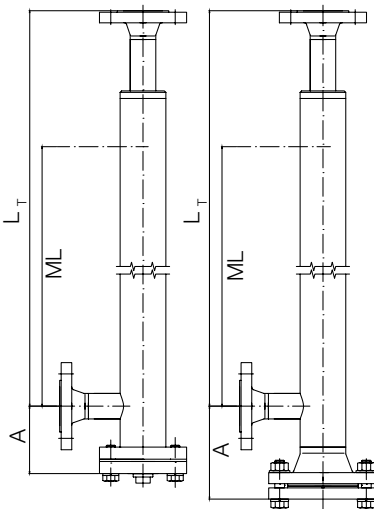

Option TS

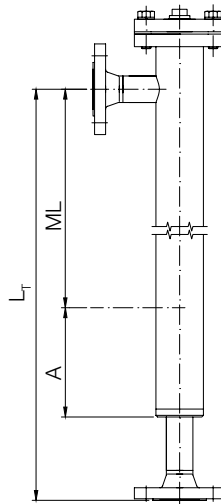

Option A

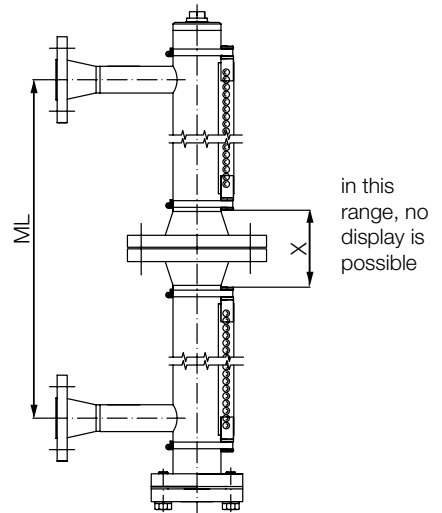

Model	Dimension X
NBK-03	92
NBK-06	98
NBK-07	127
NBK-10	139

Option HL
(centred to dimens. L)

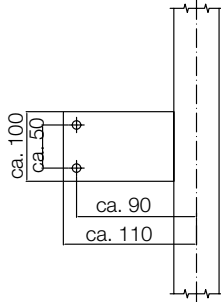

Option HF
(centred to dimens. L)

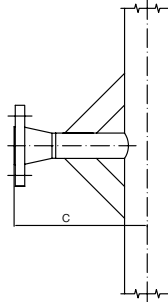

Options process connection

Option F/A

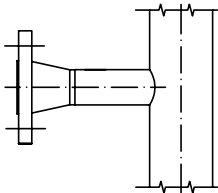

Option R/N

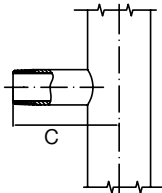

Option S

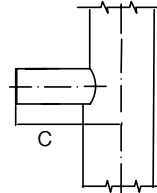

Measuring scale, aluminium

- Option M1 - engraved scale
- Option M2 - polyester foil

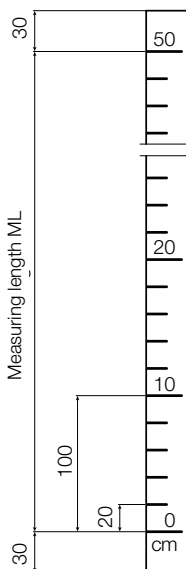

Measuring scale screen print st. steel carrier

(standard scope of supply with ball display)

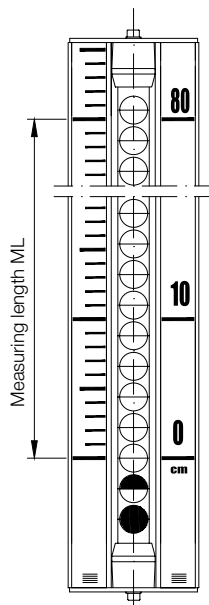

Float models (closed design)

Model	min. density [kg/dm ³]	Material
A	1.0	Titan
B	0.9	Titan
C	0.8	Titan
D	0.7	Titan
E	0.6	Titan
F*	0.54	Titan
V	1.0	stainless steel
W	0.8	stainless steel
H	0.8	CF340
Interface float	min. density difference = 150 kg/dm ³ (indicate both densities)	Titan

*Option N not possible. Not for NBK-10, special float for special medium densities (taring) or reduced length A on request



ATEX version

Order Details (Example: **NBK-03 F15 00 1 A 0**)

Model	Rated pressure	Connection	Nominal size	Roller/ ball indicator	Sensor/ Transmitter	Medium density float	Options
NBK-03...	PN16/Class 150	F = DIN-flange A = ASME-flange R³⁾ = R-male thread N³⁾ = NPT-male thread S⁴⁾ = welding-nipple	15 = DN 15, ½" 20 = DN 20, ¾" 25 = DN 25, 1" 32 = DN 32, 1 ¼" 40 = DN 40, 1 ½" 50 = DN 50, 2"	00 = without RP = POM roller RK = ceramic roller KP = ball display with Plexiglas®-sight tube KM = ball display with Makrolon®-sight tube KF = like KM but with oil filling KG = ball display with borosilicate sight tube	1 = without electrical attached parts ATEX II 1G / 2G D 2¹⁾ = with reed contact chain II 1GD Exia IIC T6 E¹⁾ = immersible magnetic probe (reed chain)/ 4-20 mA, 2-wire, ATEX Exia R = immersible magnetic probe (reed chain)/ 4-20 mA, HART®, 2-wire, ATEX Exia B = immersible magnetic probe (reed chain)/ Profibus® PA Foundation™ Fieldbus®, ATEX Exia 4 = with reed contact chain ATEX II 1/2G Exd IIC T6 Ga/Gb L = immersible magnetic probe (reed chain)/ 4-20 mA, 2-wire, ATEX Exd K = immersible magnetic probe (reed chain)/ 4-20 mA, HART®, 2-wire, ATEX Exd N = immersible magnetic probe (reed chain)/ Profibus® PA Foundation™ Fieldbus®, ATEX Exd	A = 1.0 kg/dm³, titan for viscosity up to 200 cP B = 0.90 kg/dm³, titan for viscosity up to 200 cP C = 0.80 kg/dm³, titan for viscosity up to 200 cP D = 0.70 kg/dm³, titan for viscosity up to 200 cP E = 0.60 kg/dm³, titan for viscosity up to 200 cP F⁵⁾ = 0.54 kg/dm³, titan for viscosity up to 200 cP V⁵⁾ = 1.0 kg/dm³, stainless steel for viscosity up to 460 mm²/s W⁵⁾ = 0.8 kg/dm³, stainless steel for viscosity up to 460 mm²/s Y = special density, titan (specify in clear text) H = high pressure-refloat, CF340 viscosity up to 200 cP (medium S. G.: ≥ 0.8; specify in clear text writing)	0 = without options or options as in list and description (see separate options list)
NBK-06...	PN40/Class 300						
NBK-07...	PN63/Class 400						
NBK-10...	PN100/Class 600						
NBK-31...	PN160/Class 900	F = DIN-flange A = ASME-flange	15 = DN 15, ½" 20⁷⁾ = DN 20, ¾" 25 = DN 25, 1"	KF = like KM but with oil filling KG = ball display with borosilicate sight tube	K = immersible magnetic probe (reed chain)/ 4-20 mA, HART®, 2-wire, ATEX Exd N = immersible magnetic probe (reed chain)/ Profibus® PA Foundation™ Fieldbus®, ATEX Exd	Y = special density, titan (specify in clear text) H = high pressure-refloat, CF340 viscosity up to 200 cP (medium S. G.: ≥ 0.8; specify in clear text writing)	0 = without options or options as in list and description (see separate options list)
NBK-32...	PN250/Class 1500						
NBK-33...	PN320						
NBK-RA	ATEX limit contact, encapsulated, Ex II2G EEx m II T6/T5						

¹⁾ See separate ATEX certification of model MM-...
³⁾ Only possible with nominal size code 15/20/25/32 (female thread on request)
⁴⁾ Only possible with nominal size code 15/20/25/32
⁵⁾ Only possible with NBK-03
⁶⁾ Not possible with NBK-10
⁷⁾ Only possible for connection A, ASME

Measuring length L, density and temperature please specify in clear text!

Dimensions [mm]

NBK-ATEX version reed chain Model 2

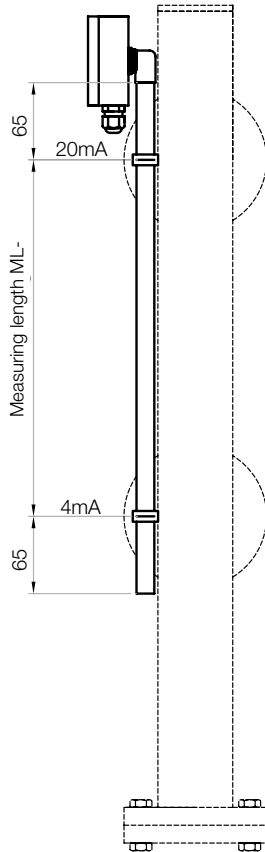

NBK

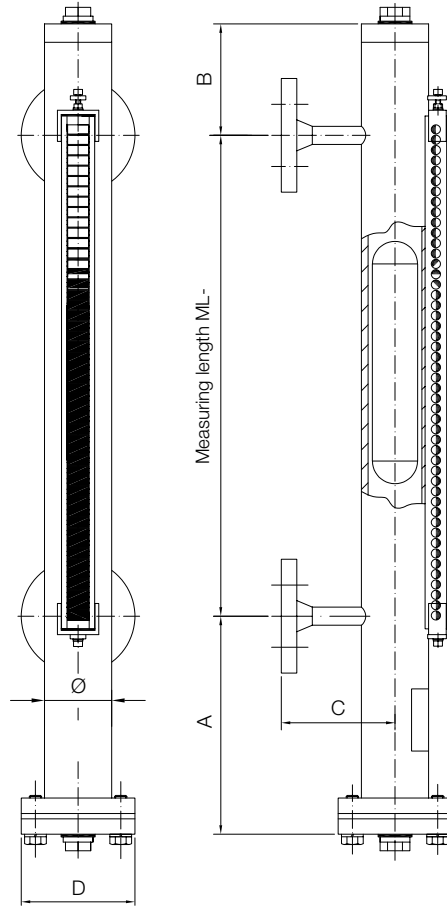

Dimensions NBK [mm]

Model	Rated pressure	Ø	B	D	x15...x25	x32	C				
							F40	A40	F50	A50	
NBK-03...	PN 16	60.3	130	115	110	110	130	-	140	-	
	Class 150						-	145	-	160	
NBK-06...	PN 40						-	155	-	165	
	Class 300						-	165	-	175	
NBK-07...	PN 63			180	150	150	145	-	160	-	
	Class 400			-			160	-	175		
NBK-10...	PN 100			195	150	150	145	-	165	-	
	Class 600			-			160	-	175		
NBK-31...	PN 160			71	150	245	180				
	Class 900										
NBK-32...	PN 250	76.1	170	265	210						
	Class 1500										
NBK-33...	PN 320										

**NBK-10/-31/-32/-33
always without vent plug
and without drain plug**

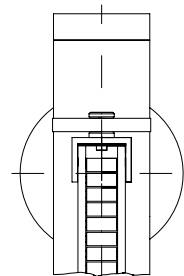

Clearance dimension A [mm]

Model	Rated pressure	Medium density					
		0.54 [kg/dm³]	0.6 [kg/dm³]	0.7 [kg/dm³]	0.8 [kg/dm³]	0.9 [kg/dm³]	1 [kg/dm³]
NBK-03...	PN 16 / Class 150	320	320	320	320	320	210
NBK-06...	PN 40 / Class 300	410	410	320	320	320	210
NBK-07...	PN 63 / Class 400	410	410	320	320	320	210
NBK-10...	PN 100 / Class 600	-	700*	410**	320	320	210
NBK-31...	PN 160 / Class 900	-	-	-	540	415	345
NBK-32...	PN 250 / Class 1500	-	-	-	540	415	345
NBK-33...	PN 320	-	-	-	595	460	385

* 800 for units with thermal screening; **450 for units with thermal screening

NBK-31/32/33 roller/ball indicator

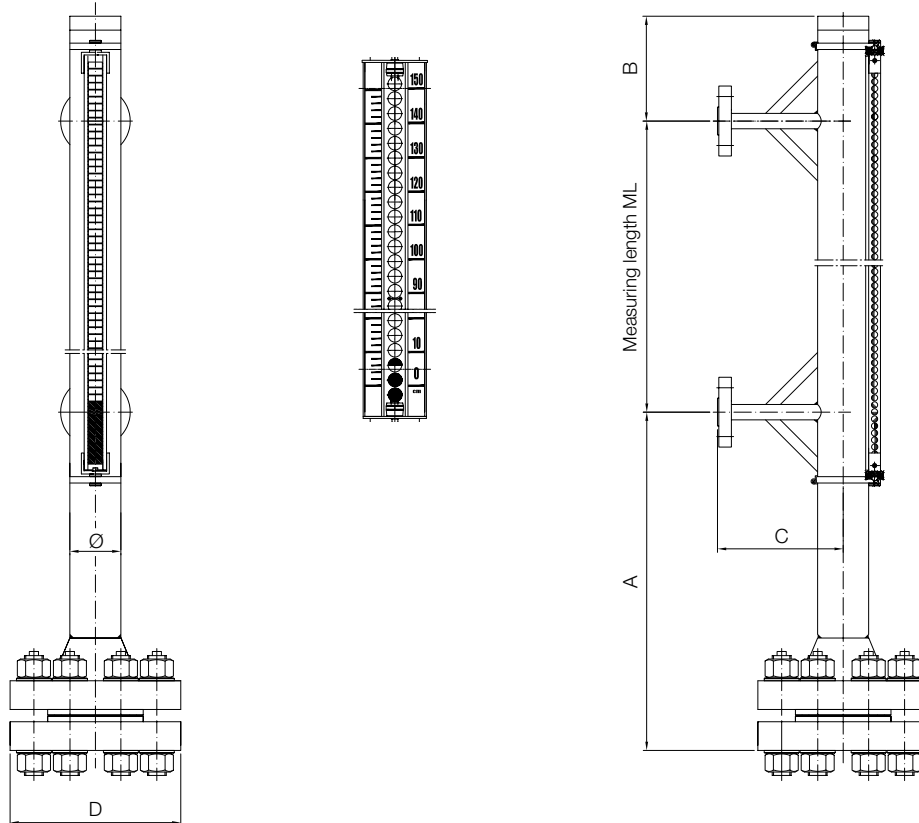

Pressure-/temperature-assignment for flange made of stainless steel

DIN EN 1092-1:2008-09 (extract)										
PN	Material	Maximum allowable temperature TS in °C								
		RT	100	150	200	250	300	350	400	
		Maximum allowable pressure PS in bar								
6	1.4571 (15E0)	6.0	6.0	5.8	5.6	5.3	5.0	4.8	4.6	
16		16.0	16.0	15.6	14.9	14.1	13.3	12.8	12.4	
40		40.0	40.0	39.2	37.3	35.4	33.3	32.1	31.2	
63		63.0	63.0	61.8	58.8	55.8	52.5	50.7	49.2	
100		100.0	100.0	98.0	93.3	88.5	83.3	80.4	78.0	
160		160.0	160.0							
250		250.0	250.0							
320		320.0	320.0							

Remarks:

RT = -10 °C up to +50 °C

TS = maximum allowable temperature in °C, temperature which is defined by pressure equipment manufacturer, for which the pressure equipment is designed.

PS = maximum allowable pressure, pressure which is defined by pressure equipment manufacturer, for which the plant is designed. 1.4571 (15E0) was calculated with help of creep resistance values of 100 000 h acc. to EN-Material Norms considering the safety value.

At intermediate temperatures e.g. 120 °C, a linear interpolation is to be carried out between 2 following creep resistance values, e.g. of 100 °C and 150 °C.

The pressure/temperature assignment is valid for the following flange models with sizes up to DN100 used by KOBOLD.

Model No. and nomination: 05 Blind flange, 11 Welding neck flange



NBK-... with transmitter options E/R/B/4/L/K/N
(not possible with options VA/VF)

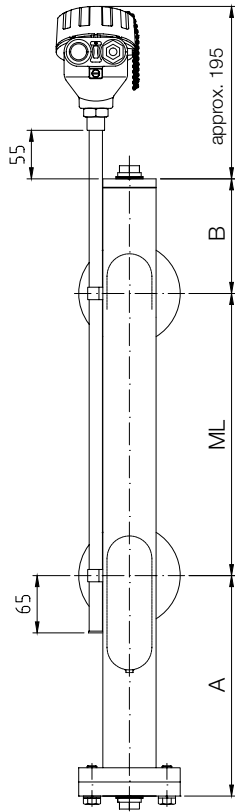

NBK-... with thermal screen option N

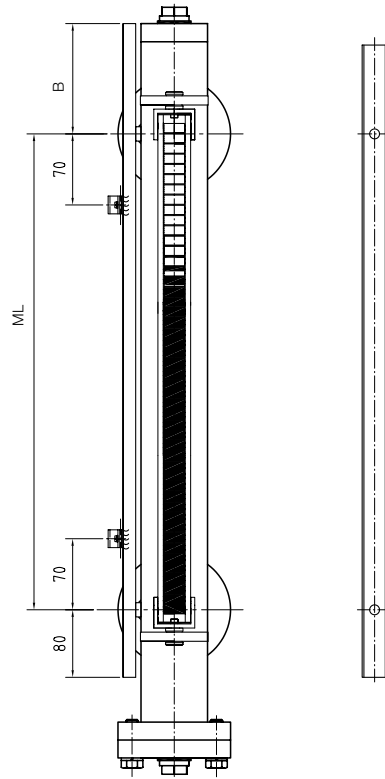

NBK-... with transmitter options 2/E/R/B/4/L/K/N and option MU

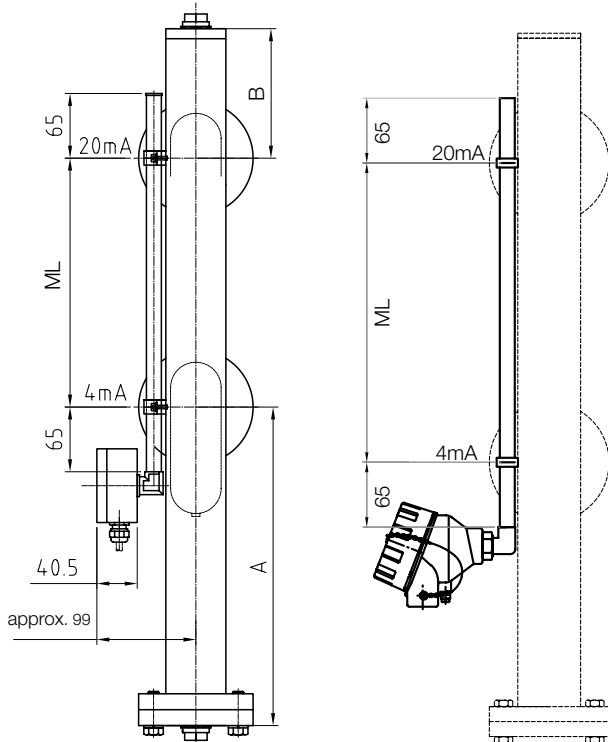

NBK-... with transmitter options 2/E/R/B/4/L/K/N and option MS

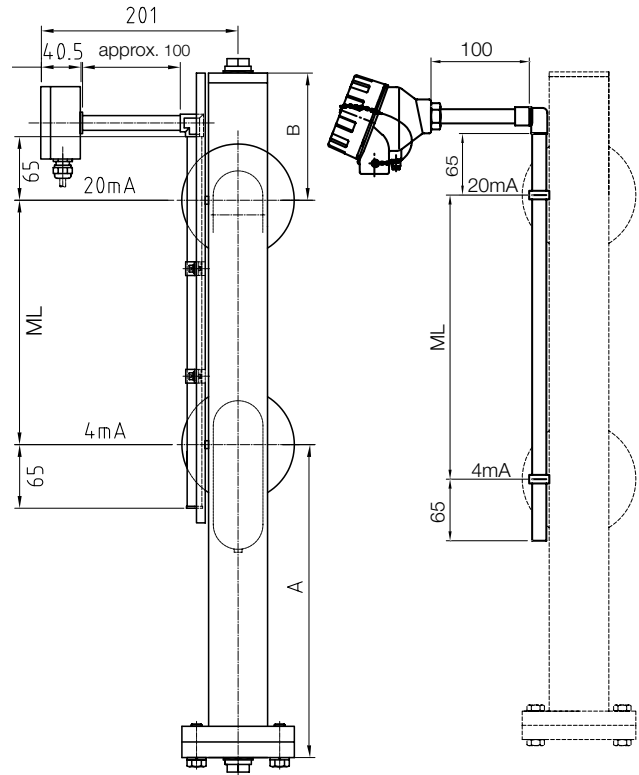

NBK-... with transmitter options E/R/L/K/ and display options LE/KE or LC/KC

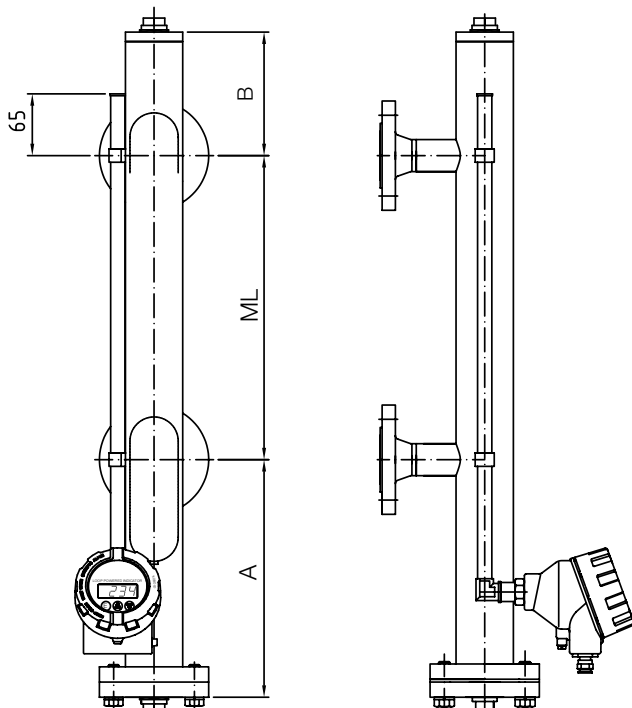

NBK-... with transmitter options E/R/L/K/ and display options LE/KE or LC/KC and option ST

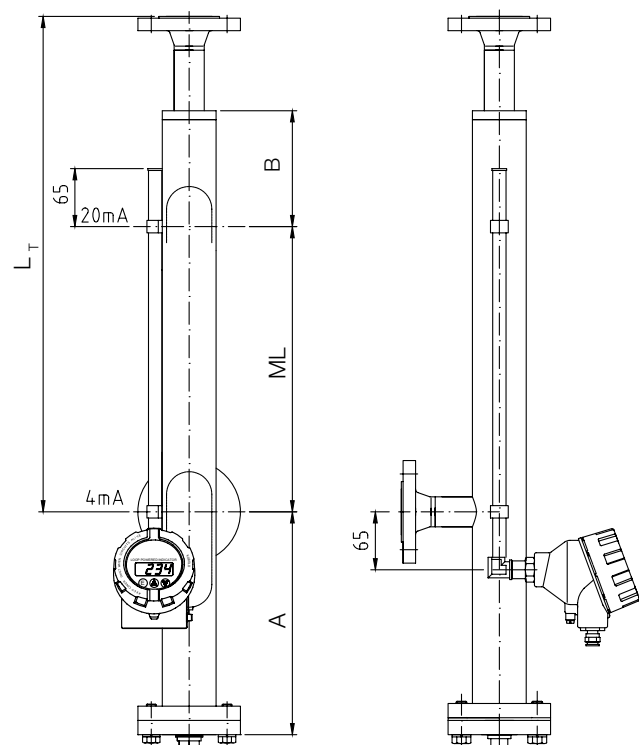

NBK... with transmitter
model E/R/B/L/K/N option ST

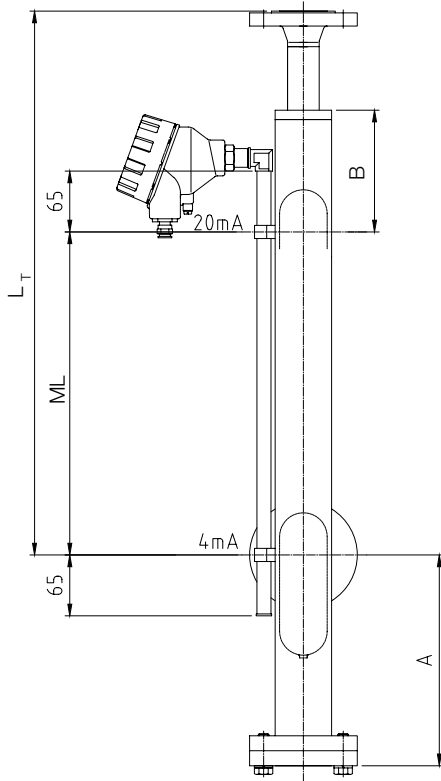

NBK... with transmitter
model E/R/B/L/K/N option TT

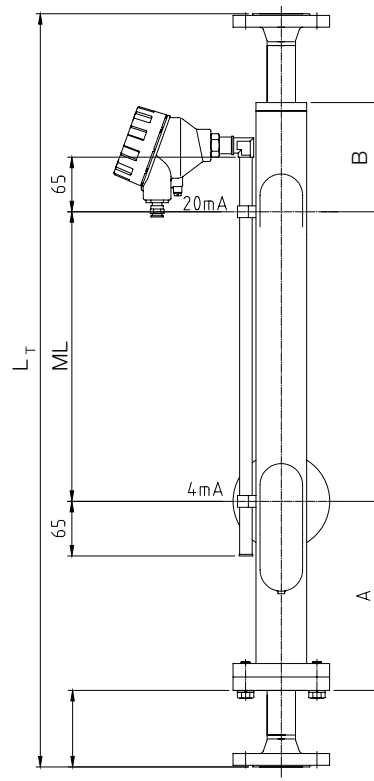

NBK... with transmitter display options
LE/KE or LC/KC and option TT

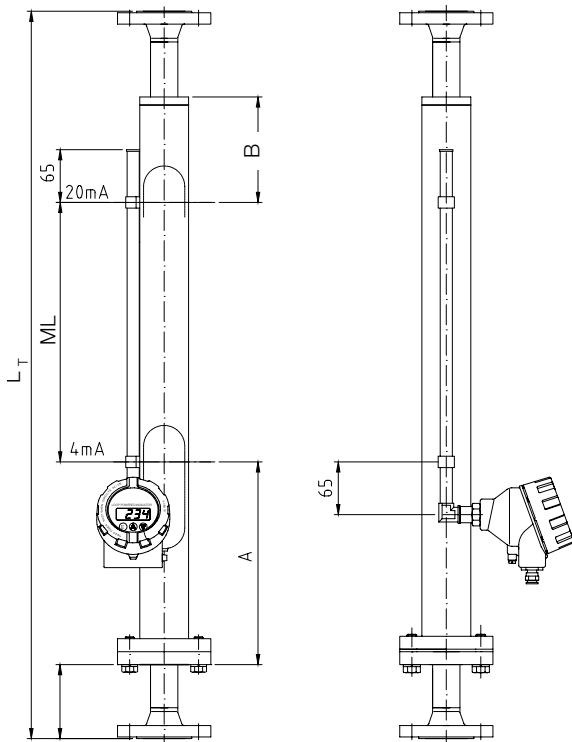

NBK-RA

