

**Operating Instructions
for
Capacitive Level Switch**

Model: LNZ



1. Contents

1. Contents.....	2
2. Note	3
3. Instrument Inspection.....	3
4. Regulation Use	3
5. Operating Principle.....	4
6. Mechanical Connection.....	5
6.1. Installation with hygienic installation system LZE	5
6.2. Installation in G1/2 thread.....	6
7. Electrical Connection	7
7.1. Model with screwed cable gland Terminal pin assignment of the 3-pole clamp	8
7.2. Model with round pin plug Connector assignment of the M12-plug	8
8. Technical Information.....	9
9. Order Codes	9
10. Dimensions	10
11. EU Declaration of Conformance	11

Manufactured and sold by:

Kobold Messring GmbH
Nordring 22-24
D-65719 Hofheim
Tel.: +49(0)6192-2990
Fax: +49(0)6192-23398
E-Mail: info.de@kobold.com
Internet: www.kobold.com

2. Note

Please read these operating instructions before unpacking and putting the unit into operation. Follow the instructions precisely as described herein.

The instruction manuals on our website www.kobold.com are always for currently manufactured version of our products. Due to technical changes, the instruction manuals available online may not always correspond to the product version you have purchased. If you need an instruction manual that corresponds to the purchased product version, you can request it from us free of charge by email (info.de@kobold.com) in PDF format, specifying the relevant invoice number and serial number. If you wish, the operating instructions can also be sent to you by post in paper form against an applicable postage fee.

The devices are only to be used, maintained and serviced by persons familiar with these operating instructions and in accordance with local regulations applying to Health & Safety and prevention of accidents.

When used in machines, the measuring unit should be used only when the machines fulfil the EC-machine guidelines.

3. Instrument Inspection

Instruments are inspected before shipping and sent out in perfect condition.

Should damage to a device be visible, we recommend a thorough inspection of the delivery packaging. In case of damage, please inform your parcel service / forwarding agent immediately, since they are responsible for damages during transit.

Scope of delivery:

The standard delivery includes:

- Capacitive Level Switch model: LNZ

4. Regulation Use

Any use of the Capacitive Level Switch, model: LNZ-N, which exceeds the manufacturer's specification, may invalidate its warranty. Therefore, any resulting damage is not the responsibility of the manufacturer. The user assumes all risk for such usage.

5. Operating Principle

The LNZ capacitive level switch is used for detecting levels of fill. The electric field penetrates several millimetres into the medium. The change in capacity caused by contact with the medium is measured and evaluated.

By using this principle of measurement, it is also possible to detect non-conductive media. Installation in tanks is very straightforward regardless of position.

In combination with the KOBOLD LZE or LZE-R weld-in sleeves, the probe provides a measuring point that has no dead space and meets hygiene standards and (EHEDG approval certificate). Installation is virtually front-flush. This level switch is therefore very well suited for CIP/SIP cleaning. Adapter sleeves are also available for different process connections so that the device can also be used in existing systems.

Because the electronics are already integrated no other evaluating instrument is necessary. The output signal (24 V_{DC}) can therefore be transmitted directly to an SPS for further processing.

6. Mechanical Connection

Installation: Pipe or vessel
Installation position: independent, for switching, the sensor needs to be completely wetted

6.1. Installation with hygienic installation system LZE

Welding and mounting details:

Welding in tanks and pipes:

1. Drill a hole with diameter equivalent to outer diameter of the sleeve; max. tolerance +0,2 mm
2. Weld the sleeve at 4 points
3. Screw in the blind socket
4. Weld the sleeve segments between already welded 4 points.
4 sleeve segments for M12 and G 1/2"; 8 sleeve parts for G1"

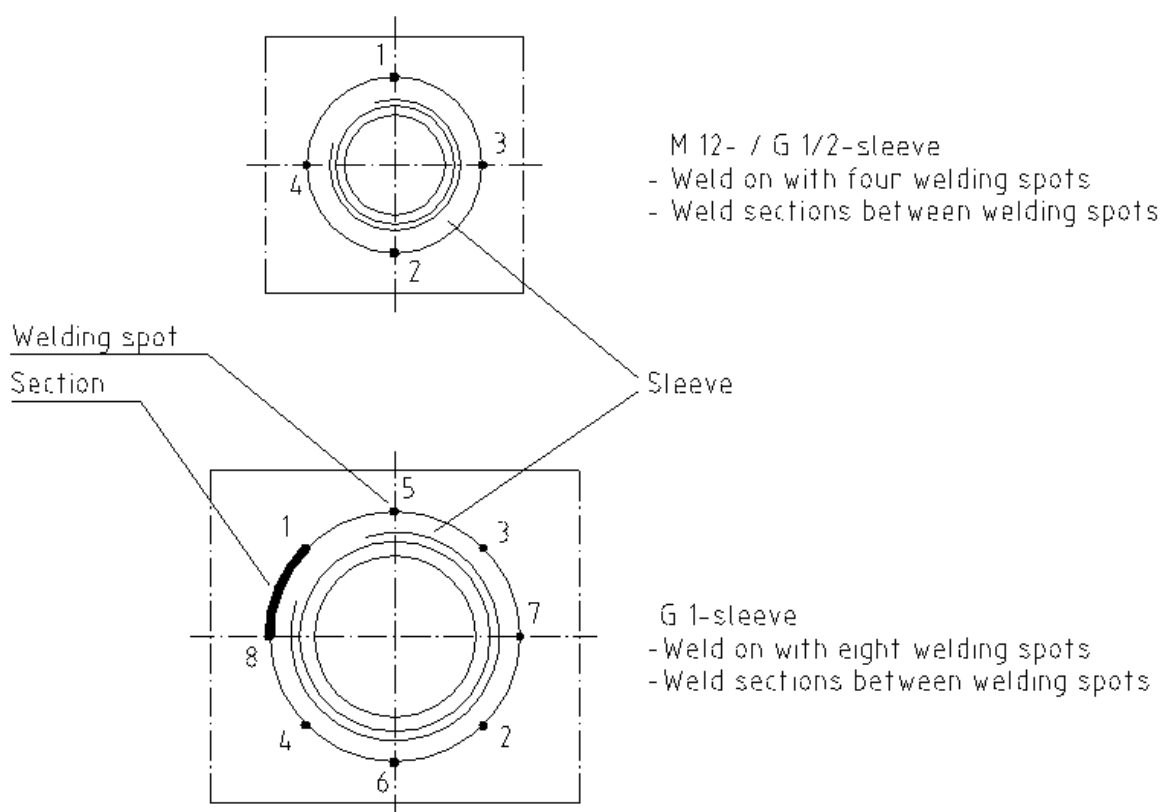

Attention! In order to avoid deforming or red-hot turning of the sleeve, pauses between individual sleeve segments should be sufficient enough to allow cooling down of the sleeve.

- Pay attention to the maximum allowable torque of 10 – 15 Nm when you screw in the sensor (instrument connection G1/2).
- Please avoid frequent screwing in and unscrewing of the sensor from the sleeve, because on high stress, the sealing edge can distort and the process connection can get leaky.
The sealing system is designed for CIP- and SIP-cleaning.

6.2. Installation in G1/2 thread

If the sleeve LZE is not used for the installation of the level switch LNZ, it is possible to seal the screw thread with an adequate sealing material. Thus, an installation is possible in a pipe as well as in a vessel.

No conductive connection needs to be established to the vessel or to the pipe.

7. Electrical Connection



Attention! Make sure that the voltage values of your system correspond with the voltage values of the measuring unit.

- Make sure that the supply wires are de-energised.
- Connect the supply wires and the output signal to the shown pins as indicated in section 7.1 / 7.2.
- We recommend the use of wires with cross sectional area of min. 0,25 mm²



Attention! A wrong connection of the plug pins can damage the unit's electronic!

7.1. Model with screwed cable gland Terminal pin assignment of the 3-pole clamp

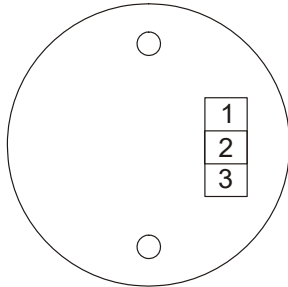

Power supply clamp 1	Power supply clamp 2	Sensor	Output clamp 3	Switching function
GND	+ V _s	immersed	approx. V _s	N/O contact
		dry	approx. 0 V	N/O contact
+ V _s	GND	immersed	approx. 0 V	N/C contact
		dry	approx. V _s	N/C contact

The output function (N/O / N/C function) is switched through by the polarity of the power supply.

7.2. Model with round pin plug Connector assignment of the M12-plug

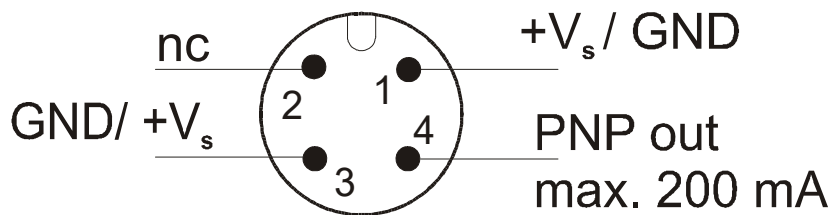

Power supply plug PIN 1	Power supply plug PIN 3	Sensor	Output plug PIN 4	Switching function
GND	+ V _s	immersed	approx. V _s	N/O contact
		dry	approx. 0 V	N/O contact
+ V _s	GND	Immersed	approx. 0 V	N/C contact
		dry	approx. V _s	N/C contact

The output function (N/O / N/C function) is switched through by the polarity of the power supply.

8. Technical Information

Measuring principle:	capacitive
Process temperature:	0...100 °C 150 °C max. 30 min for CIP process
Ambient temperature:	0...70 °C
Working pressure:	max. 10 bar
Material	
• Head, thread supports:	stainless steel 1.4404
• Coupler section:	PEEK, stainless steel 1.4404
Process connection:	G ½, hygienic weld-in sleeve LZE, LZE-R
Connection:	threaded cable connection M16 x 1.5 Terminal: 3-pole, (optional plug M12 x1)
Function:	Full / empty report (determined via the polarity of the supply voltage)
Output:	Open Collector, PNP, max. 200 mA
Switch delay (fixed):	approx. 0.2 s
Power supply:	24 V _{DC} , ±20%, < 10 mA without load
Protection:	IP 67
Weight:	approx. 0.5 kg
Dielectric constant of the medium:	$\epsilon_R > 20$

9. Order Codes

Example: LNZ-12 G4 3PK

Model	Material	Process connection	Electrical connection
LNZ-	12 = stainless steel	G4 = G 1/2	3PK = M16x1.5 threaded cable connection 3PS = M12x1 plug

EHEDG-certification of the connection system
cable connection with weld-in sleeve LZE.

10. Dimensions

Single-Rod Probe

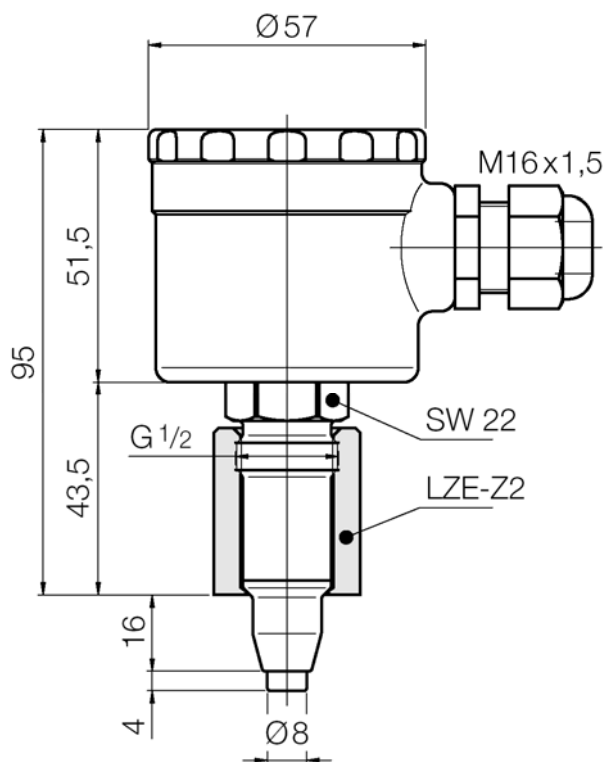
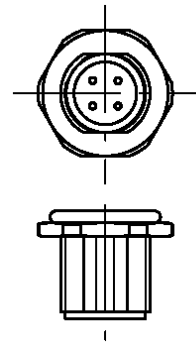
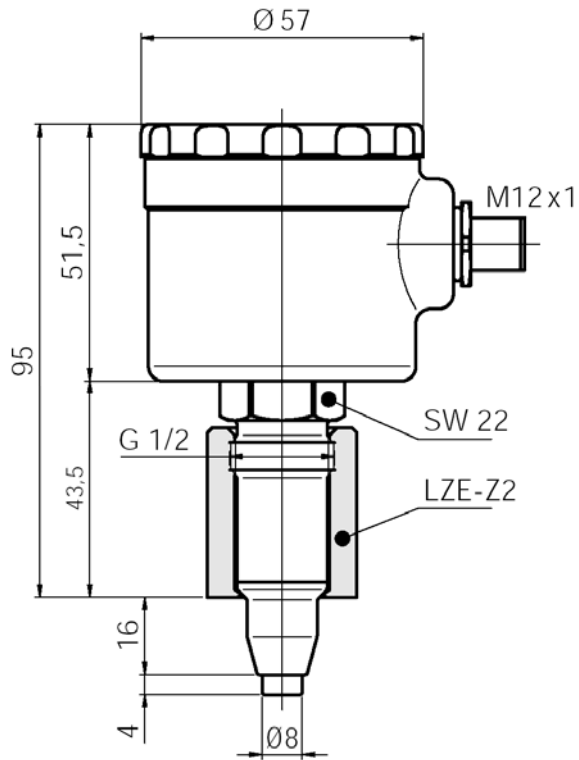

11. EU Declaration of Conformance

We, KOBOLD-Messring GmbH, Hofheim-Ts, Germany, declare under our sole responsibility that the product:

Capacitive Level Switch Model: LNZ

to which this declaration relates is in conformity with the standards noted below:

EN 61326-1:2013

Electrical equipment for measurement, control and laboratory use - EMC requirements - Part 1: General requirements

EN IEC 63000:2018 Technical documentation for the assessment of electrical and electronic products with respect to the restriction of hazardous substances

Also, the following EEC guidelines are fulfilled:

2014/30/EU	Electromagnetic compatibility
2011/65/EU	RoHS (category 9)
2015/863/EU	Delegated Directive (RoHS III)

We confirm that the material PEEK is approved by FDA without any limitations for direct contact with food and pharma products and fulfils the corresponding EU-regulation.

FDA Approval-No. 21 CFR 177.2415
EU Regulation 1935/2004

Hofheim, 13 April 2022



H. Volz
General Manager



M. Wenzel
Proxy Holder