



**Operating Instructions**  
**for**  
**Ball Valves**  
**with Pneumatic Actuator**  
**Model: KUP-...**



## 1. Contents

---

1. Contents.....	2
2. Note .....	4
3. Instrument Inspection.....	4
4. Specific application .....	4
5. Safety notes .....	5
5.1. Safety of personnel.....	5
5.2. Safety of machinery .....	6
6. Operating principles .....	7
6.1. General information .....	7
6.2. Design.....	7
6.3. Function „double-acting“ .....	7
6.4. Function „single-acting“.....	8
7. Rotation Direction.....	9
7.1. Change of the rotation direction.....	9
7.2. Change of the rotation direction at actuator with function „double-acting“ .....	10
8. Ambient conditions.....	12
9. Assembly Instructions .....	12
9.1. Mechanical mounting.....	12
9.2. Pneumatically Installation .....	15
9.3. Disassembly .....	18
10. Adjustment/Starting.....	19
10.1. Adjustments .....	19
10.2. Starting .....	20
11. Emergency Operation .....	20
12. Failure .....	21
12.1. Failure causes .....	22
13. Maintenance/Cleaning .....	22
13.1. Maintenance .....	22
13.2. Mounting of the spare part kit .....	22
13.3. Cleaning.....	27
14. Device Description .....	28
15. Technical details .....	29
16. Order Codes .....	29
17. Dimensions [mm] .....	29
18. Disposal .....	30
19. EC Declaration of Conformance .....	31

**Manufactured and sold by:**

Kobold Messring GmbH  
Nordring 22-24  
D-65719 Hofheim  
Tel.: +49(0)6192-2990  
Fax: +49(0)6192-23398  
E-Mail: [info.de@kobold.com](mailto:info.de@kobold.com)  
Internet: [www.kobold.com](http://www.kobold.com)

## 2. Note

---

Please read and take note of these operating instructions before unpacking and putting the unit in operation, and follow the instructions precisely as described herein.

The instruction manuals on our website [www.kobold.com](http://www.kobold.com) are always for currently manufactured version of our products. Due to technical changes, the instruction manuals available online may not always correspond to the product version you have purchased. If you need an instruction manual that corresponds to the purchased product version, you can request it from us free of charge by email ([info.de@kobold.com](mailto:info.de@kobold.com)) in PDF format, specifying the relevant invoice number and serial number. If you wish, the operating instructions can also be sent to you by post in paper form against an applicable postage fee.

Operating instructions, data sheet, approvals and further information via the QR code on the device or via [www.kobold.com](http://www.kobold.com)

The devices are only to be used, maintained and serviced by persons familiar with these operating instructions and with the prevailing regulation applying to operational safety and the prevention of accidents.

When used in machinery, the device may only be placed in operation if the machine in use complies with the EEC machinery guidelines.

## 3. Instrument Inspection

---

Instruments are inspected before shipping and sent out in perfect condition. Should damage to a device be visible, we recommend a thorough inspection of the delivery packaging. In case of damage, please inform your parcel service / forwarding agent immediately, since they are responsible for damages during transit.

### **Scope of delivery:**

The standard delivery includes:

- Ball valve with pneumatic activator      model: KUP-...
- Optional: solenoid valves, limit switches

## 4. Specific application

---

Model KUP pneumatic actuators can be employed to automatically open and close ball valves with the help of control air. Do not use an aggressive gas as a control fluid. We recommend, instead, the use of filtered air. The fitting material and gaskets must be resistant to the medium flowing in the pipe.

## **5. Safety notes**

---

You must pay attention to special safety aspects depending on the prevailing technical conditions and the time at which you install and adjust the actuator, and put it into operation!

For example, you will be exposed to much greater risks when placing the device in operation if you open or close a pipe in an operational chemical plant with the pneumatically operated ball valve than when you place the device in operation for test purposes at a "dry" section of the plant in the assembling hall.

Because we cannot predict the conditions that will apply at the time of installation/adjustment/putting into operation, we have provided a comprehensive list of risk notes below, some of which may not apply to your particular application.

Please follow the instructions that apply to your situation only!

### **5.1. Safety of personnel**

#### **5.1.1. Safety notes for installation**

We expressly point out that the installation, electrical wiring and adjustment of the rotary actuator should only be carried out by trained and skilled personnel with sound mechanical and electrical technical skills!

- Shutdown all devices/machinery/plant affected by the installation or repairs!  
If necessary, disconnect the devices/machinery/plant from the electrical supply!
- Make sure you do not introduce risk by shutting down devices/machinery/plant in chemical plant, for example!
- You should inform the shift supervisor, the health and safety engineer, or the plant manager immediately about any fault that occurs with the ball valve with pneumatic rotary actuator in a running plant. This is to avoid any discharge/overflow of chemicals or leakage of gases by taking suitable precautionary measures!
- Depressurize pneumatic/hydraulic devices/machinery/plant before installation and service!
- Attach warning labels to devices/machinery/plant to prevent someone from unintentionally putting them into operation.
- Installation and servicing should be carried out in compliance with the appropriate professional/trade association safety and accident prevention regulations.
- Check that safety devices (e. g. emergency stop buttons, relief valves, etc.) are working correctly.
- Before mounting check, the rotation direction and the position of the actuator.

## 5.1.2. Safety notes for adjustment / starting

As a result of the starting (pneumatic or by hand) of a pneumatic actuator the position of a flanged slide/valve/flap will be changed!

Therefore, the flow of gases, steam, liquids, etc. may be enabled or interrupted!

- Satisfy yourself that, as a result of the starting or the test adjustment no potential hazards will be produced for the personnel or the environment!
- If necessary, set up warning signs in order to prevent the inadvertent starting up or shutting down of the device/machine/plant!
- By ending the adjustment check the correct function and should the occasion arise the position of the slide/valve/flap.
- Check the function of the limit switches (option)!
- Check, whether the slide/valve/flap will be closed totally, if the control signals the appropriate limit stop!
- Through suitable measures, prevent actuating links being trapped by moving actuating elements!
- Check the right function of all safety devices (for example emergency push off buttons / safety valves)!
- Carry out the starting and the adjustments only in accordance with the instructions described in this documentation!
- When adjustments are being carried out on a switched-on actuator with options (e.g. solenoid valves, limit switches) there is the risk that live parts (230V AC~) can be touched!  
Therefore, the adjustments must be carried out only by the electrician or a person having adequate training, who is aware of the potential hazard!

## 5.2. Safety of machinery

The rotary actuator is a quality product which is produced in accordance with the recognized industrial regulations. It left the manufacturers work in a perfect safety condition!

In order to maintain this condition, as installer/user you must carry out your task in accordance with the description in these instructions, technically correctly and with the greatest possible precision.

We assume, as trained specialist you are having mechanical and electrical knowledge!

- The pneumatic actuator must be used only for a purpose corresponding to its construction!
- The pneumatic actuator must be used within the actuator specified in the technical data!

- The operation of the pneumatic actuator beyond the admissible temperature range will overburden or damage the sealings and bearing.
- The operation of the pneumatic actuator beyond the admissible working pressure will damages the internal parts and the body.
- Never remove or loosen the caps or accessories, if the actuator will be under pressure or will be connected with a supply voltage (option).
- Satisfy yourself that, as a result of the mounting, the starting or as a result of the test adjustment on the pneumatic actuator, no potential hazards will be produced for device/machine/plant!
- Do not mount the actuator, start the actuator or carry out any adjustments on it, if the actuator, the supply lines or the part of the plant on which it is mounted is damaged!
- Before mounting the actuator check the smooth movement of the slide/valve/flap on which the actuator will be mounted.
- By ending mounting check the correct function and adjustment of the actuator and check the correct function of the options (e.g. solenoid valve, limit switch).

## **6. Operating principles**

---

### **6.1. General information**

The actuator is a pneumatic twin-piston drive, designed primarily for operating ball valves and butterfly valves. A double-action and a spring-return (single-action) type is available. The twin-piston system affords a high torque with minimum overall dimensions. The rotation angle is adjustable with the standard settings by  $\pm 6$  degrees.

### **6.2. Design**

Due the twin-piston system the force developed by the counter-running pistons is transmitted to one common pinion via two racks solidly connected with the piston. This principle ensures a linear torque transmission along the entire stroke.

### **6.3. Function „double-acting“**

Pressure is given through port „P1“ into the actuator between the two piston surfaces. The pistons expand and transfers the force to the pinion which turn round counterclockwise about  $90^\circ$  -> the actuator moves into position „OPEN“. By giving compressed air through port „P2“, port „P1“ exhausts, the pressure in both chambers between the caps and pistons will increase and the pistons will strike against themselves. Therefore the pinion turns clockwise about  $90^\circ$  ->the actuator moves into position „CLOSE“ (see Fig.).

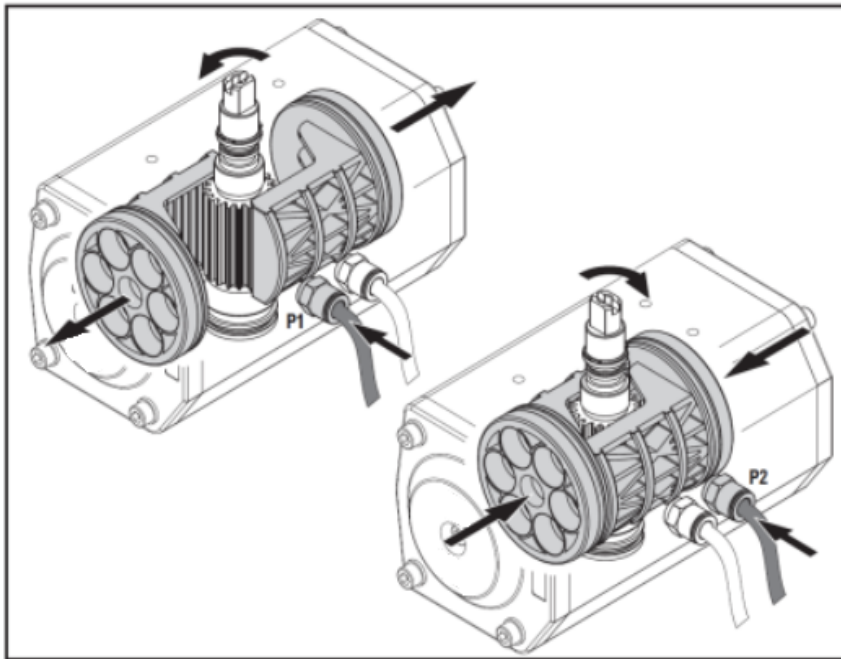

Description of function, double-acting

## 6.4. Function „single-acting“

Pressure is given through port „P1“ into the actuator between the two piston surfaces. The pistons expand against the spring force. The pistons force will be transfer to the pinion by racks. The pinion turns round counterclockwise about 90° ->the actuator moves into the position „OPEN“. Exhausting the port „P1“ the pistons will be replaced by the spring force. Therefore the pinion turns clockwise about 90° -> the actuator moves into the position „Close“. The springs will be able to adjust to the working conditions (see Fig.).

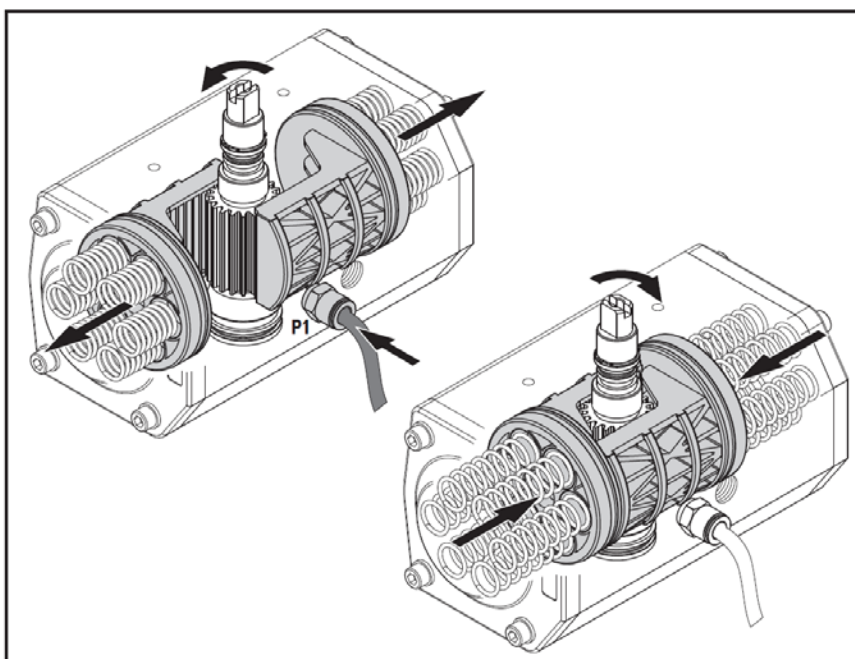

Description of function, single-acting



## 7. Rotation Direction

The pneumatic actuators are available as „right revolving“ or „left revolving“ actuators.

The standard rotation direction is to turn left. The rotation direction of the pinion of the pneumatic actuator will be counterclockwise to be open and clockwise to be close. The rotation direction refers to a view on the top of the actuator (see Fig.). Before mounting the pneumatic actuator on a slide/valve/flap, take care that the rotation direction will be practicable in your case. If appropriate, you have to change the rotation direction by reconstructing the pistons of the actuator.

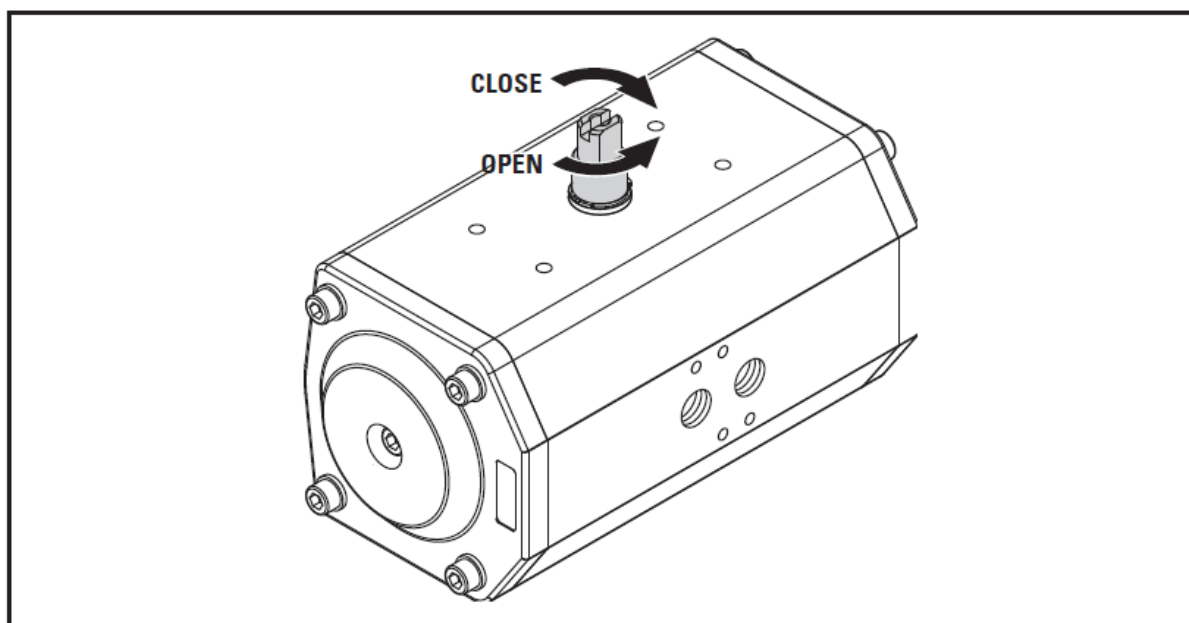

Rotation direction

### 7.1. Change of the rotation direction

In the following description we assume, that you have read the former chapters attentive. We also assume that you will observe the safety advices and warnings from chapter 5. „Safety advice“ during the mounting / disassembly.

**Do not open a pneumatic actuator with the function „single acting“ on no account!**

**If you have not read chapter 5. „Safety advices“ until now, read these important advices now and turn back to this page!**

The following description based on the assumption, that the pneumatic actuator is not been mount-ed on a slide/valve/flap. All accessories have to be removed. The mentioned rotation direction refers to the standard rotation direction „closed by rotating clockwise“.

During the working at an opened actuator take care for great cleanness, because even little pollution should cause a hasten wear or will damage the sealings and the treads.

## 7.2. Change of the rotation direction at actuator with function „double-acting“

Loosen the cap bolts (1).

**At single-acting pneumatic actuators the changing of the rotation direction will be permitted only by the manufacturer. Do not loosen or screw out the cap bolts. There will be a high tension at the caps causes by the resilience.**

Remove the caps (2) and put them aside. The caps are symmetrical and therefore the caps could be mounted both on the left and the right end of body (5).

Turn round the shaft (3) counterclockwise with a spanner until the racks of the pistons (4) and the pinion at the shaft didn't mesh anymore.

Do not drive out the pistons with compressed air.

The pistons have to stand out from the body now. Turn back the shaft clockwise about 90°.

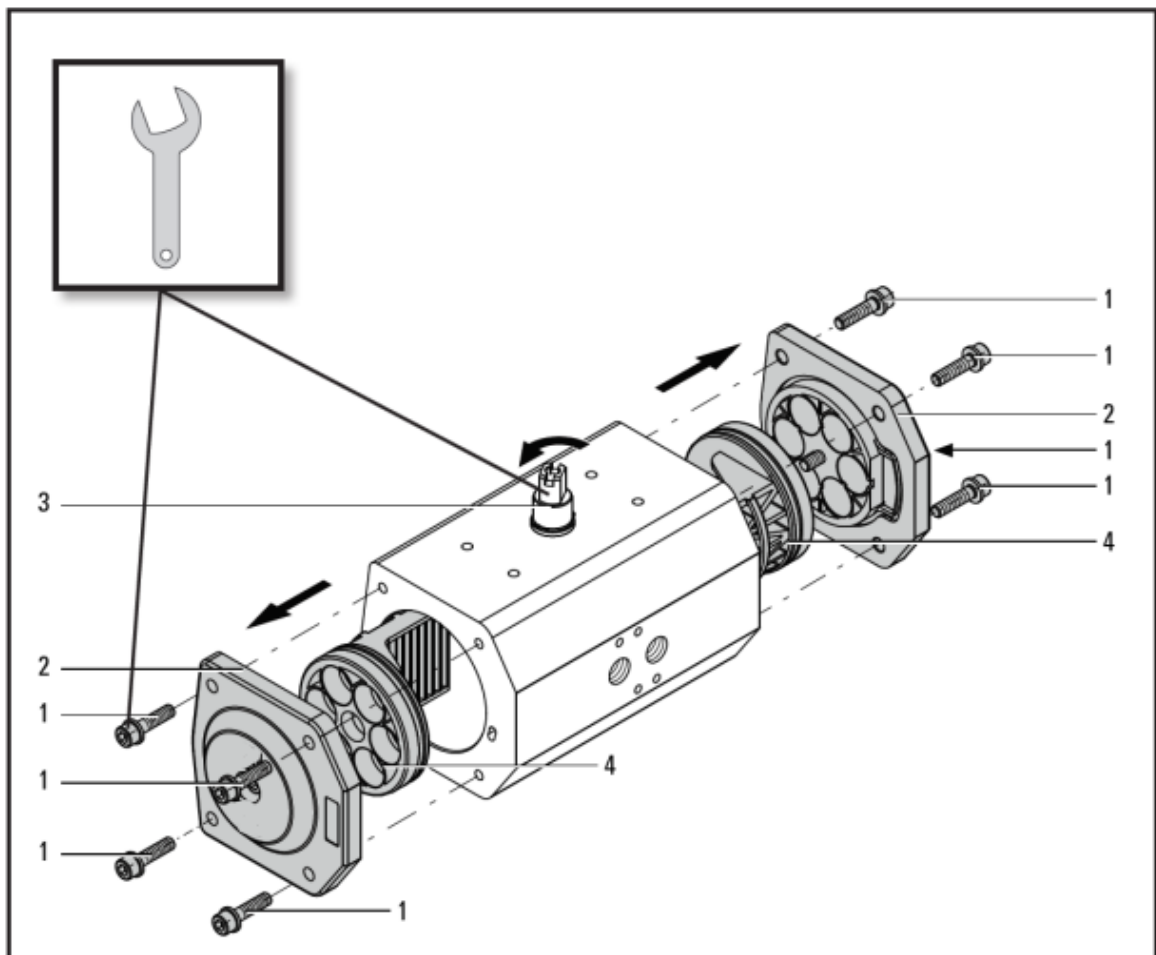

Change of the rotation direction, Removing the caps

Turn around the pistons (1) about 180°, don't take the pistons out of the body (2) at this (see Fig.)

Insert the piston (1) into the body, so that both racks (3) will mesh into the teeth of the shaft (4) at the same time. Observe the turning direction of the shaft.

Turn the shaft counterclockwise with a spanner until the groove of the shaft will be at right angles to the axle of the actuator. The pistons have to strike against themselves and that the piston will be symmetrically in the body.

If appropriate, repeat the working operations to adjust the shaft.

Put the cap onto the body and align it. Put the cap seals into the sealing groove of the cap and check the right placement. Screw the cap bolts with the washers into the body and tighten them crosswise.

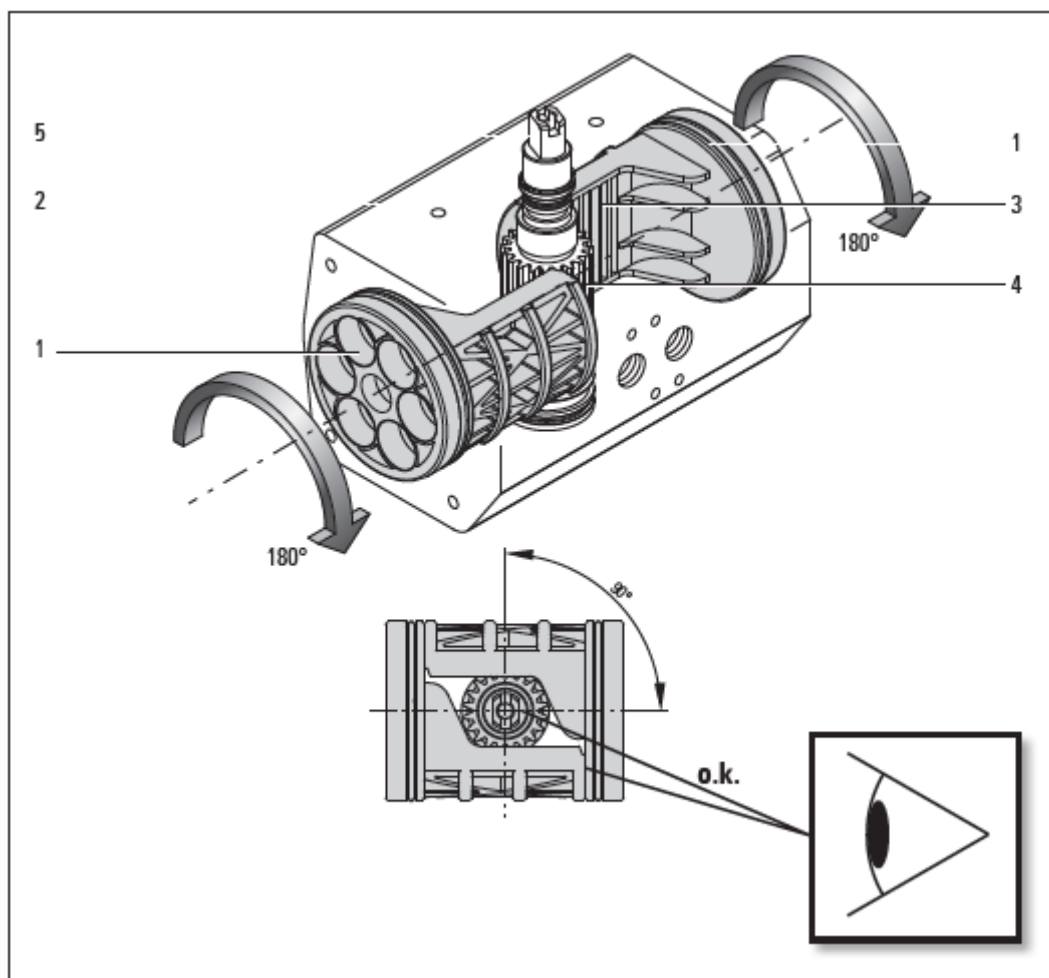

Change of the rotation direction, Turning of the pistons

## 8. Ambient conditions

---

The pneumatic actuator KUP is designed for industrial operating conditions! However, some special conditions are to be observed for its mounting and subsequent operation!

Take care that

- the actuator is mounted in accordance with the mounting advice listed below.
- the actuator is used in accordance with the characteristic values specified in the technical data.

The non-observance of the mounting advice or the use outside the specified characteristic values can have a negative influence on the functional reliability of the actuator.

## 9. Assembly Instructions

---

The mounting of the pneumatic actuator KUP is restricted to:

- the mechanical mounting of the actuator on a slide/valve/flap,
- the pneumatically installation of the actuator with the pilot air lead, and
- if need be the mounting and connection of options and accessories.

The mounting position of the actuator ED/EE is arbitrary.

**In the following description we assume, that you have read the former chapters attentive! We also assume that you will observe the safety advices and warnings from chapter 5 „Safety advice“ during the mounting / disassembly.**

If you have not read chapter 5 „Safety advices“ until now, read this important advices now and turn back to this page!

The mounting and the pneumatically (electrical) installation must be carried out only by trained specialist personnel having mechanical (and electrical) knowledge.

Which variant of the device you have will be seen on the name-plate on the back of the pneumatic actuator KUP.

The explanation of the designation will be found in the datasheet.

### 9.1. Mechanical mounting

Two mounting variants are available:

- directly mounting, or
- mounting with a bracket and a stem

Before mounting you have to fix a qualified mounting variant for your application. Directly mounting will be able, if the dimensions of the shafts and the ISO - flanges of the actuator and the slide/valve/flap are the same. Differences of the dimension for the stem of the slide/valve/flap will be able to be equalized by available bushings (option) in some cases.

A mounting with bracket and stem will be necessary, if the differences of the dimensions between the shaft of the actuator and the stem of the slide/valve/flap are not able to be equalized by a bushing or the ISO-flanges did not match.

This mounting variant will also be used by high/low medium temperatures or voluminous isolated pipes.

By mounting with bracket and stem observe also the mounting device of the supplier of these parts.

Do not drill any holes into the body of the actuator- the damage of the actuator or an insufficient fastening of the actuator will be the result.

### 9.1.1. Directly mounting

Ensure that the actuator and the slide/valve/flap will be in position „CLOSE“.

Put the bottom side of the actuator to the slide/valve/flap that the stem will enter into the octagonal boring of the shaft of the actuator. If necessary, use an appropriate bushing (options), to equalize differences of the dimension between the stem and the shaft.

Align the actuator to the slide/valve/flap.

Put the actuator onto the stem of the slide/valve/flap until the surface of the actuator cling to the ISO - flange of the slide/valve/flap. If this operation will be ponderous the shaft of the actuator will be driven onto the stem of the slide/valve/flap by slightly strokes with a plastic hammer.

Fasten the actuator with fit bolts. Observe the maximum depth of the threaded holes of the actuator. Would there be two sizes of hole circles to fasten the actuator, you have always to use the greater one.

Tighten the screws. Therefore, observe the maximum torque of the chosen screws.

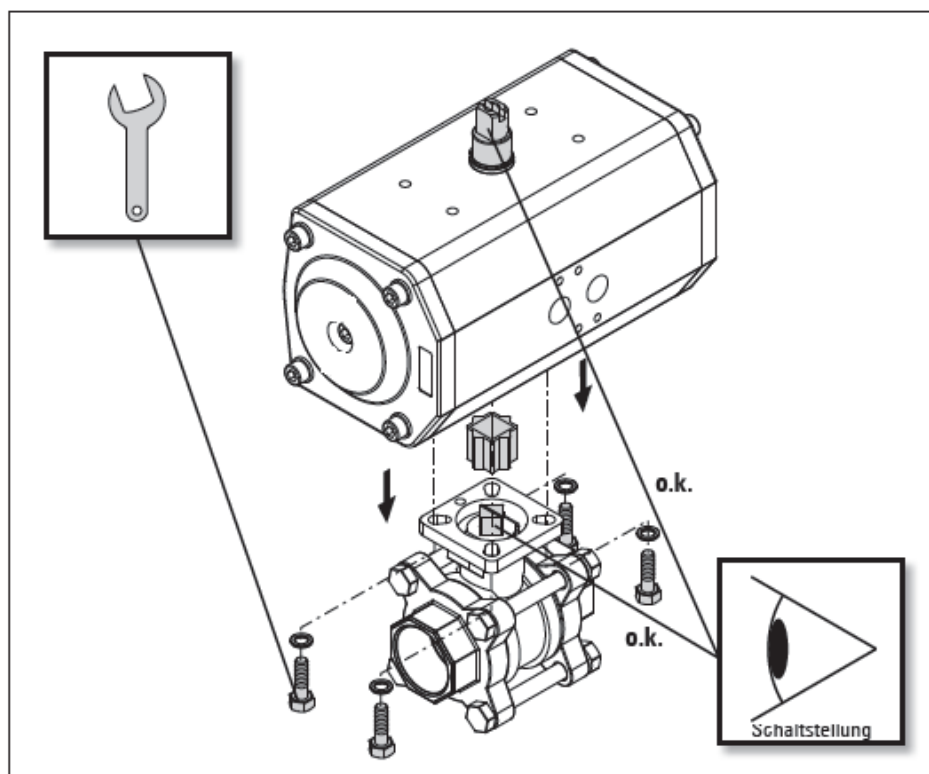

Mounting / disassembly, directly mounting

## 9.1.2. Mounting by bracket and stem

Ensure that the actuator and the slide/valve/flap will be in position „CLOSE“.

Put the stem onto the stem of the slide/valve/flap. Therefore, observe the position of possibly position indicators.

Put the bracket onto the slide/valve/flap and align them.

Fasten the bracket with fit bolts. Observe the maximum depth of the threaded holes of the actuator. Would there be two sizes of hole circles to fasten the actuator, you have always to use the greater one. Tighten the screws. Therefore, observe the maximum torque of the chosen screws.

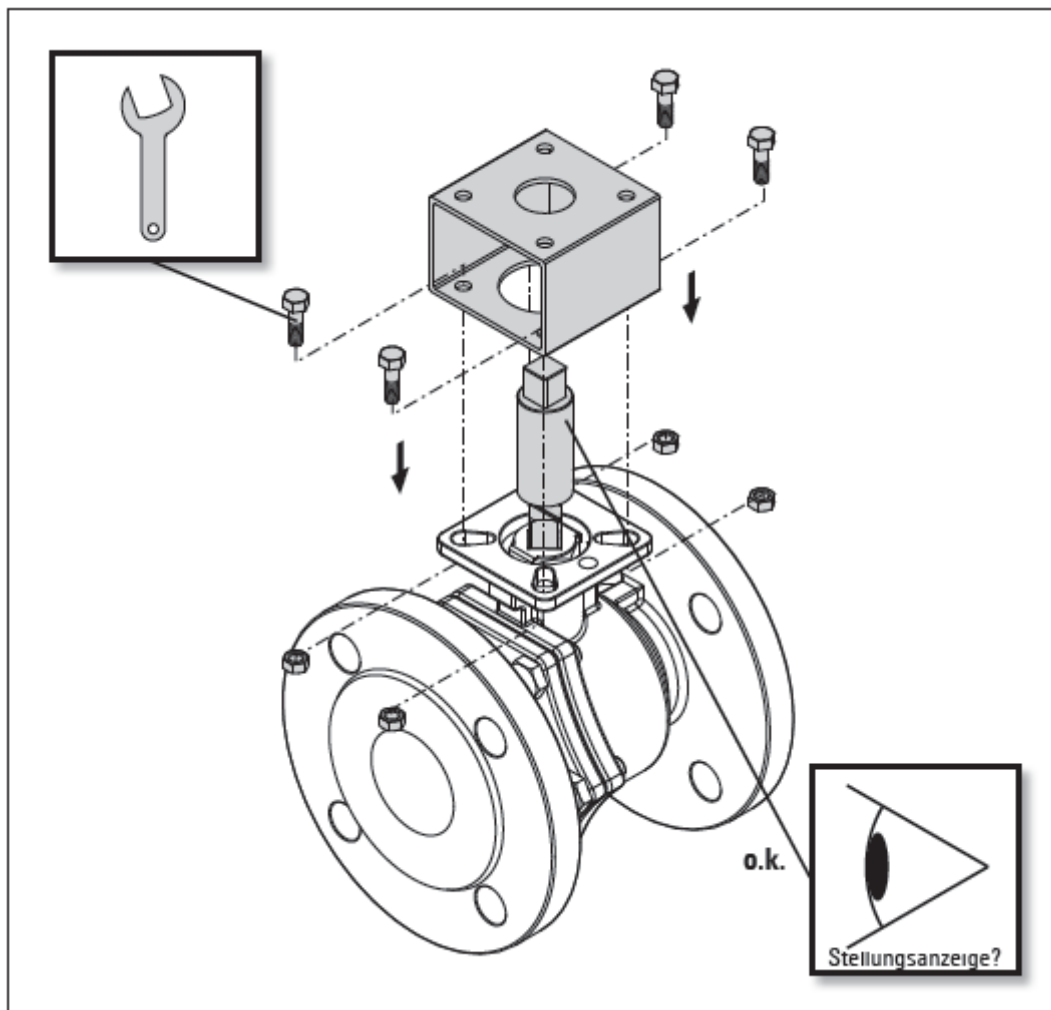

Mounting / disassembly, Mounting with bracket and stem

Put the bottom side of the actuator to the slide/valve/flap that the stem will enter into the octagonal boring of the shaft of the actuator.

Align the actuator to the slide/valve/flap resp. to the console.

Put the actuator onto the stem of the slide/valve/flap until the surface of the actuator cling to the ISO - flange of the bracket. If this operation will be ponderous the shaft of the actuator will be driven onto the stem of the slide/valve/flap by slightly strokes with a plastic hammer.

Fasten the actuator with fit bolts. Observe the maximum depth of the threaded holes of the actuator. Would there be two sizes of hole circles to fasten the actuator, you have always to use the greater one.

Tighten the screws. Therefore, observe the maximum torque of the chosen screws.

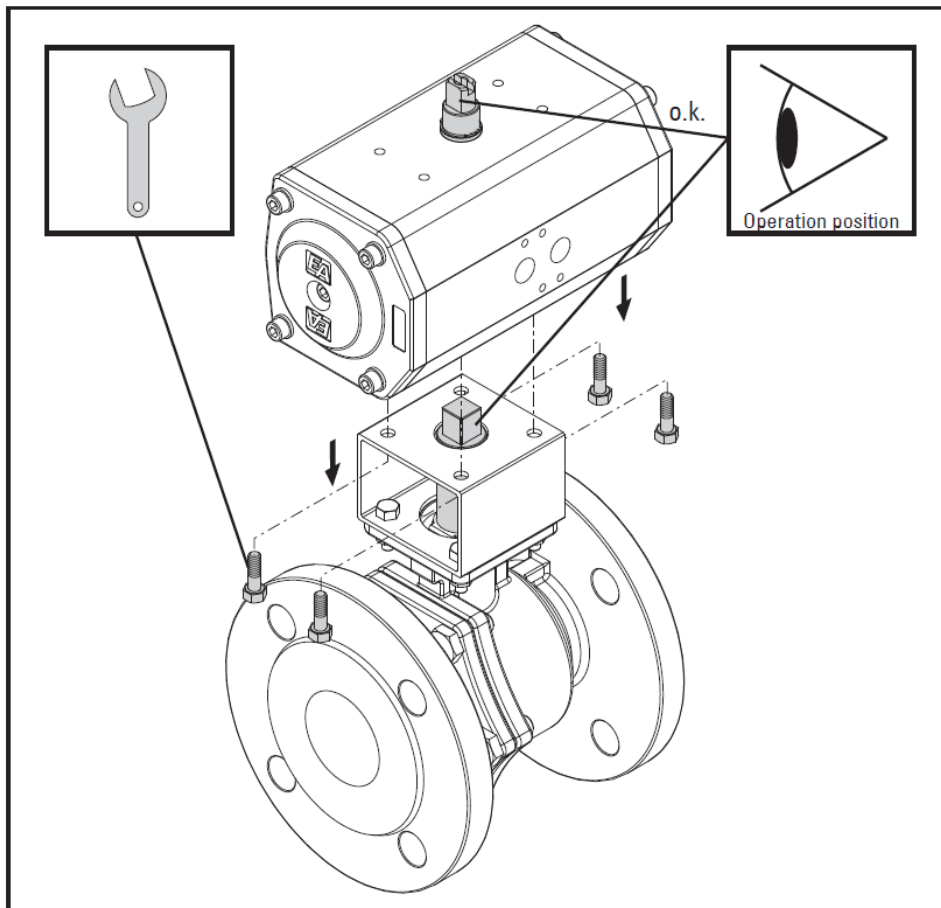

Mounting / disassembly, Mounting with console and stem

## 9.2. Pneumatically Installation

The installation of the air supply has to take place with great care. Especially the threaded connection, fittings and sealings have to be clean and free of pollution. Pollution which attains in-side the actuator, will causes hasten wear and the damage of the sealings and the treads.

The pneumatic actuator KUP is available in two operation variants:

- function double-acting, or
- function single-acting with spring return

Observe the descriptions to the name-plate.

Before the pneumatically installation will take place, you have to ascertain existing operation variant about your application. A description of the operation variants you may find at description of function.

Use only the correct hose and hose connectors for your application.

By laying the hose take care, that the hose will not be creased, squeezed or sheared or that the hose will be layed over edges. Also take care that there will be no pressure or traction in the hose.

If appropriate lay the hoses in conduits or cable ducts.

As an alternative to the shown variant the control of the actuator could take place by a directly mounted pilot valve. In this case see the enclosed operation and installation manual of the pilot valve.

### 9.2.1. Function „double-acting“

At first you have to remove the protection caps from the ports „P1“ and „P2“.

Screw in suitable pneumatic fittings (e.g. Art. C12xx or R12xx) into the ports „P1“ and „P2“ and tighten the fittings.

Insert a hose into the fitting at port „P1“ which will feed the actuator with compressed air during the opening operation.

Insert a hose into the fitting at port „P2“ which will feed the actuator with compressed air during the closing operation.

Tighten the hoses in the fittings at port „P1“ and „P2“.

Check the tightness of all connections.

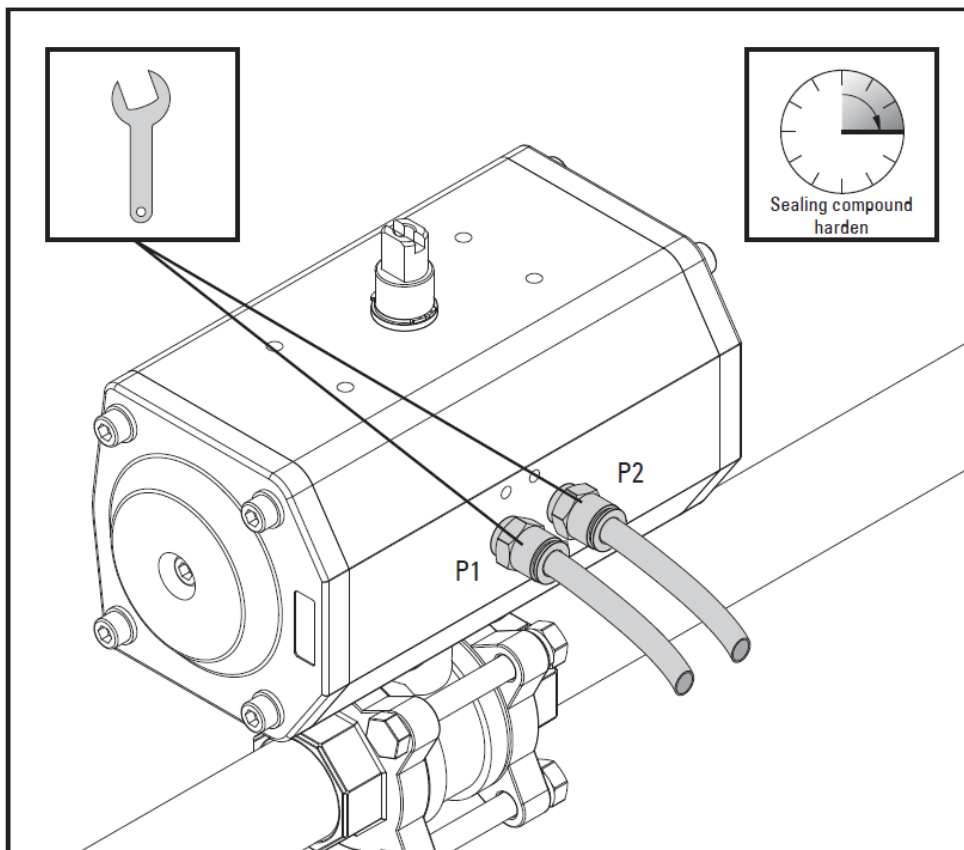

Mounting / disassembly, pneumatically installation function double-acting



### 9.2.2. Function „single-acting“

At first you have to remove the protection caps from the ports „P1“ and „P2“.

Screw in a suitable pneumatic fitting (e.g. Art. C12xx or R12xx) into the port „P1“ by using a fit sealing compound and tighten the fitting.

Insert a hose into the fitting at port „P1“ which will feed the actuator with compressed air during the opening operation.

Screw in a throttle valve with silencer (e.g. Art. AX1000xx) into the port „P2“ by using a fit sealing compound and tighten the throttle valve.

Tighten the hose in the fitting at port „P1“.

Check the tightness of all connections.

This completes the mounting and the pneumatically installation of the actuator.

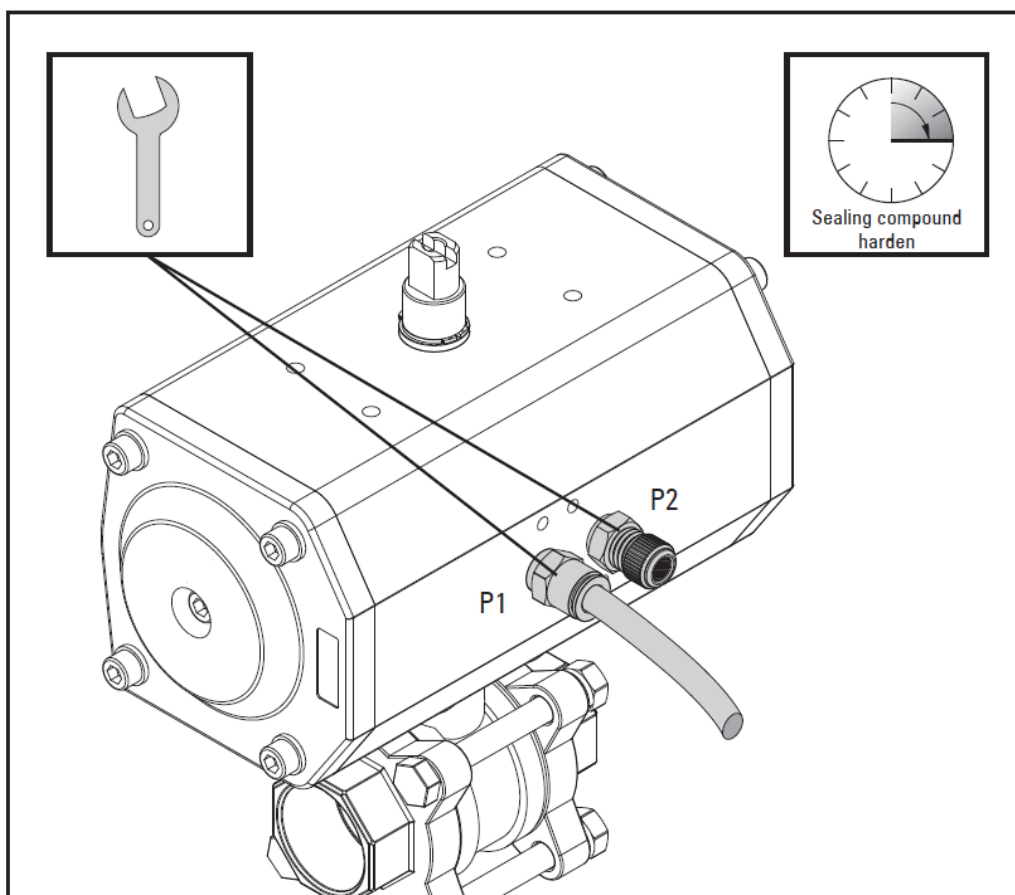

Mounting / disassembly, pneumatically installation function, single acting

## 9.3. Disassembly

Although the disassembly of an actuator in principle proceeds in the reverse sequence to the mounting, some essential points should be clarified!

In order, for example, for the operational chemical plant which was mentioned at the beginning to remain in operation:

- Will the actuator to be disassembled be replaced immediately by another (or equal valve)? If not, in which position should the actuator be, following the disassembly?
- Must the actuator be fixed in its intended position?
- If appropriate, does the production process of the plant need to be stopped?
- Is it necessary to inform specific personnel about the disassembly? Etc.

**Never remove an armature under pressure.**

**Ball valves are able to enclose the pressurize medium. Release the pressure in the pipes, to relieve the pressure at the armature.**

### 9.3.1. Pneumatically disassembly

Turn the actuator with the slide/valve/flap into its fix position! Switch off the compressed air supply and the control of the actuator! If necessary, set up warning signs in order to prevent

- the inadvertent starting up of the devices / machines / plants, or
- the switching on of power supply of the control of the actuator.

Loosen the fitting of the pilot medium and take away the pipe of the pilot medium. Close the pipe of the pilot medium if the pipe is not also being disassembled or is not to be immediately reconnected to another pneumatic actuator.

### 9.3.2. Mechanical disassembly

Unscrew the four fastening screws of the actuator and pull the actuator from mounting position. This completes the disassembly of the actuator.

---

## 10. Adjustment/Starting

---

Before you open the actuator, undertake adjustments by hand or start the actuator, you have to read chapter 5.

If you have read chapter 5 „safety advice“ until now, read these important advices now and turn back to this page.

The following descriptions are based on the assumption

- the actuator is installed on a slide/valve/flap.
- the function of the actuator in conjunction with the slide/valve/flap has been checked.
- the limit position of the slide/valve/flap is visible.

If appropriate, take note of chapter Mounting/Disassembly.

### 10.1. Adjustments

The pneumatic actuator KUP will be adjusted exactly by the manufacturer after mounting on a slide/valve/flap. Perhaps a new adjustment of the actuator will be necessary after disassembling and mounting on a new slide/valve/flap.

Before you undertake adjustments on actuators which are installed in operational plant, find out whether feeding control leads with pressure (e. g. by „OPEN“ or „CLOSE“ operation) will have influence on further actuators or whether the closing/opening of limit switches (options) will trigger (mal)functioning of other devices.

If appropriate, disconnect these leads from the actuator to be adjusted!

Never put any limbs and never insert anything into the slide/valve/flap. Heavy injuries or damages will be the consequence.

Never adjust the adjusting screws against the efficacy of pressure.

Put the pistons of the actuator together by feeding the port „P2“ with compressed air (only function double-acting), or exhausted port „ P1“ (only function single-acting).

Loosen the nuts (1) in both caps.

Turn one of the adjustment screws (2) into the cap (3), until the screw aligns with the cap or the screw will be deeper about max. 2mm.

Separate the pistons by feeding the port P1 with compressed air.

Turn out the adjustment screw (2), until the rotation angel of 90° or the desired rotation angle will be reached.

Screw the adjustment screw of the second cap against the piston, until you will feel the increase of the necessary torque moment.

Secure the adjustment screws by tighten the nuts (1). Take care that the adjustment screw will not turn.

Check the adjustment and if neccessary correct it.

By this the adjustment of the pneumatic actuator will be finished.

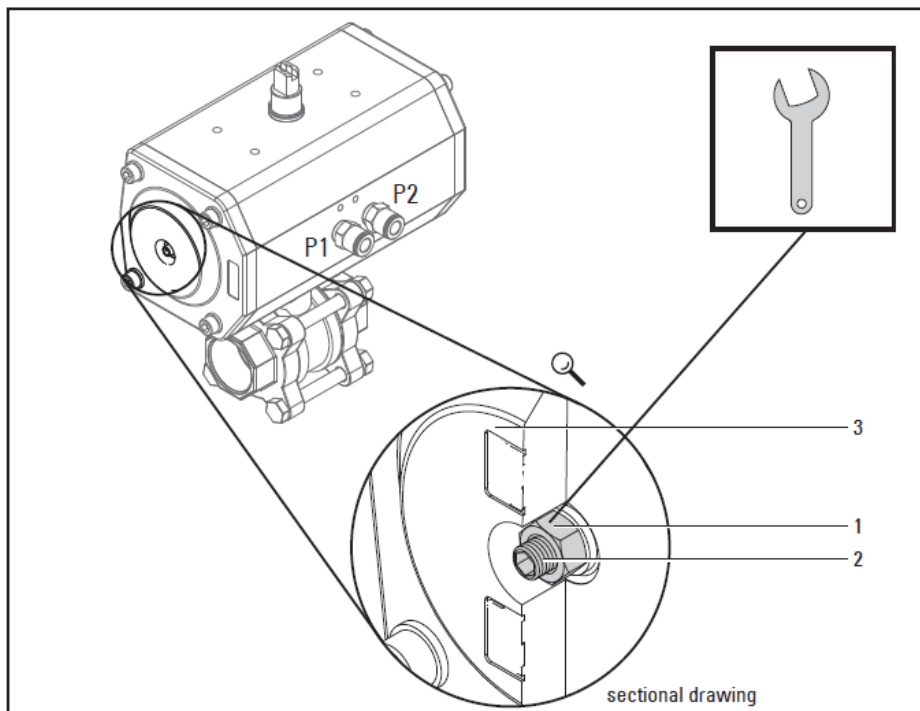

Adjustment/Starting

## 10.2. Starting

Before starting the pneumatic actuator KUP, you have to read chapter 5.

If you have not read chapter 5 „safety advice“ until now read these important advices now and turn back to this page.

The starting of a pneumatic actuator which is mounted in a plant (e.g. in a refinery or in a chemical plant) should only happen in accordance with

- the instructions of the hole plant!
- after carrying-out the adjustments described in chapter 10.1 „Adjustment“!

Switch on the power supply of the control.

Switch on the compressed air supply.

Actuate the pneumatic actuator by hand with the control and check the correct function of the actuator and the mounted slide/valve/flap.

Check all pipe connections for tightness.

Check all the pilot leads for tightness.

Check the function of the accessory units.

## 11. Emergency Operation

---

In case of a breakdown of the supplying with compressed air or the power supply or in case of trouble with the pneumatic actuator you can actuate the slide/valve/flap with the pneumatic actuator by hand.

Caution, relieve the actuator of pressure.

Take care in order to prevent the inadvertent starting.

Put an appropriate spanner onto the flanks on the top of the shaft of the actuator. Turn the shaft in the direction as desired. At this don't turn the pistons forcible against the limit stops, because such action would destroy the actuator.

Observe at single acting actuators you will need a higher torque moment and the actuator turns back into limit position by spring force immediately.

Caution! At single acting actuators there will be a risk of violation by jerking shafts.

Remove the spanner from the shaft.

If necessary, inform the shift foreman/ safety engineer or the manager about the disturbance without delay in order, for example, to avoid an outflow/ overflow of chemicals or a discharge of gases in good time by means of suitable measures!

Do not fasten any tools or handles at the shaft. By switching on the compressed air supply or the power supply these tools and handles will be turn around rapidly and entail destructions and violations!

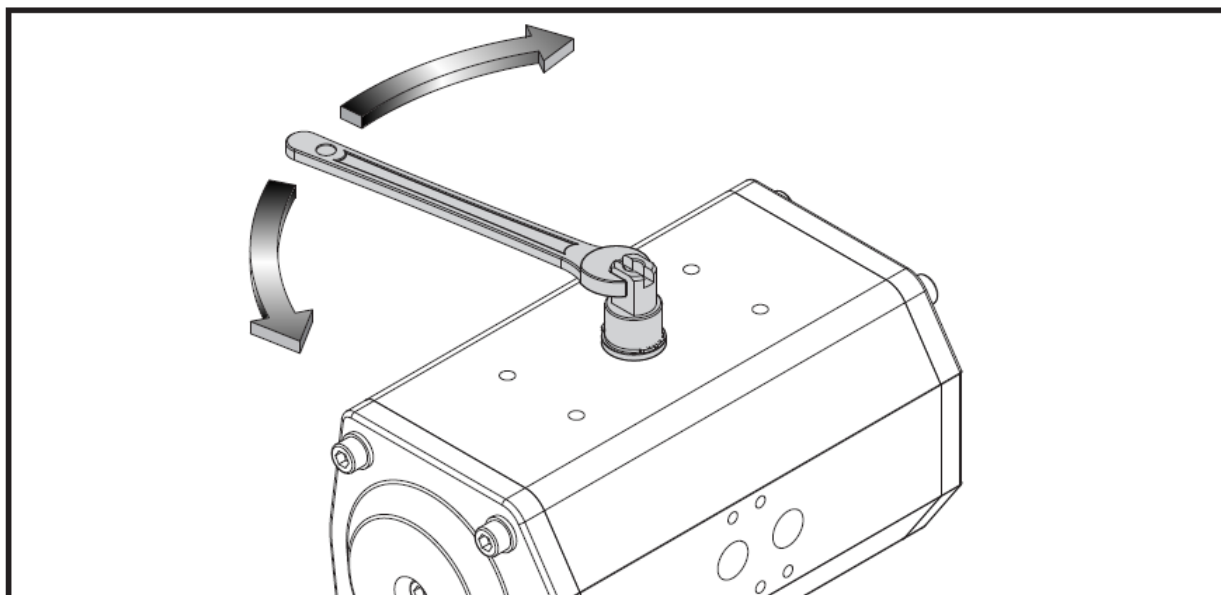

Emergency Operation

## 12. Failure

If, during the test run or during operation, a functional fault of the pneumatic actuator should occur, you are requested to carry out the adjustment of the slide/valve/flap (in an emergency) by hand. See also chapter 11 Emergency Operation.

**If necessary, inform the shift manager/safety engineer or the manager about the disturbance without delay in order, for example, to avoid an outflow/overflow of chemicals or a discharge of gases in good time by means of suitable measures.**

Next, using the following list (12.1 Failure causes), attempt to find the reason for the causes of the failure and, if it lies within your capabilities, to correct this.

Do not try to repair the pneumatic actuator!

Isolate the failed pneumatic actuator from the power supply disconnect the providing with com-pressed air!

In case of defect in the pneumatic actuator make contact with the supplier. The telephone number will be found on the back cover of these mounting and installation manual.

## 12.1. Failure causes

- Is the power supply to the control switched on?
- Is the device for the compressed air switched on?
- Are the leads from the controller to the pressure actuated valve undamaged?
- Is the actuator mounted correctly on the slide/valve/flap?
- Is the slide/valve/flap able to move smooth?

## 13. Maintenance/Cleaning

---

### 13.1. Maintenance

On normal accounts the pneumatic actuator KUP is maintenance free. In regular turns check the tightness of the pneumatic actuator.

- are the cap seals tight?
- is the pinion seal on the top and on the bottom of the actuator tight?
- are the hose fittings tight?
- are the body or the caps cracked?
- is the seal of the limit stop adjusting screw tight?
- are the counter nuts have got loose?

In case of a defect in the pneumatic actuator make contact with the supplier. The telephone number will be found on the back cover of this operation and installation manual.

**If you determine that there is a damage to the actuator, isolate it from the pilot pressure and the power supply. However, before doing this, it is essential to refer to the Safety advice (chapter 5).**

In dependence of the environment the replacement of the sealings and guide rings will be necessary at ca. 500.000 up to 1.000.000 shiftings. These spare part kits are also deliverable.

**In the following description we assume, that you have read the former chapters attentive. We also assume that you will observe the safety advices and warning notes from chapter 3 „Safety advice“ during the mounting/disassembly!**

**If you have not read chapter 3 „Safety advice“ until now, read these important advices now and turn back to this page!**

### 13.2. Mounting of the spare part kit

The following description based on the assumption, that the pneumatic actuator is not been mount-ed on a slide/valve/flap and that the control leads are disconnected. All accessories have to be removed.

The opening of a single-acting pneumatic actuator is permissible only by the manufacturer.

During the working at an opened actuator take care for great cleanness, because even little pollution should cause a hasten wear or will damage the sealings and the treads.

### 13.2.1. Mounting of the spare part kit at the actuator KUP with function „double acting“

Loosen the cap bolts (1).

Remove the caps (2) and put them aside. The caps are symmetrical and therefore the caps could be mounted both on the left and the right end of body (5).

Push the pistons (4) out of the body (5) by turning the pinion (3) with a spanner. Put also the pistons aside.

**Do not drive out the pistons with compressed air.**

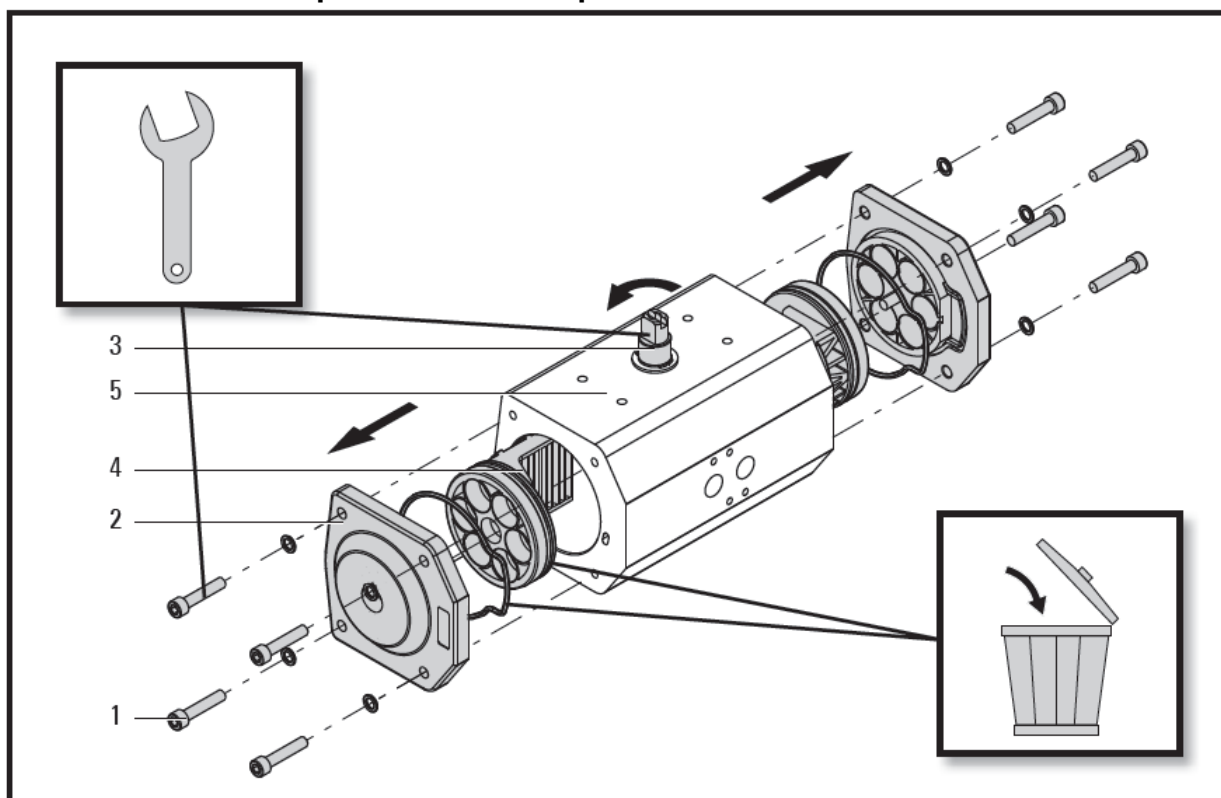

Maintenance – Mounting of the spare part kit

Remove the spring clip (6) from the shaft by fit tongs. Take off the bearing bush (7).

Take off the shaft from the body by pressing it downwards. Do not drop the shaft with the pinion. If the shaft does not permit removing by hand, you can drive out the shaft by slightly strokes with a plastic hammer on the top of the shaft.

Remove all the sealings and guide rings and throw them away by observing your national guide lines.

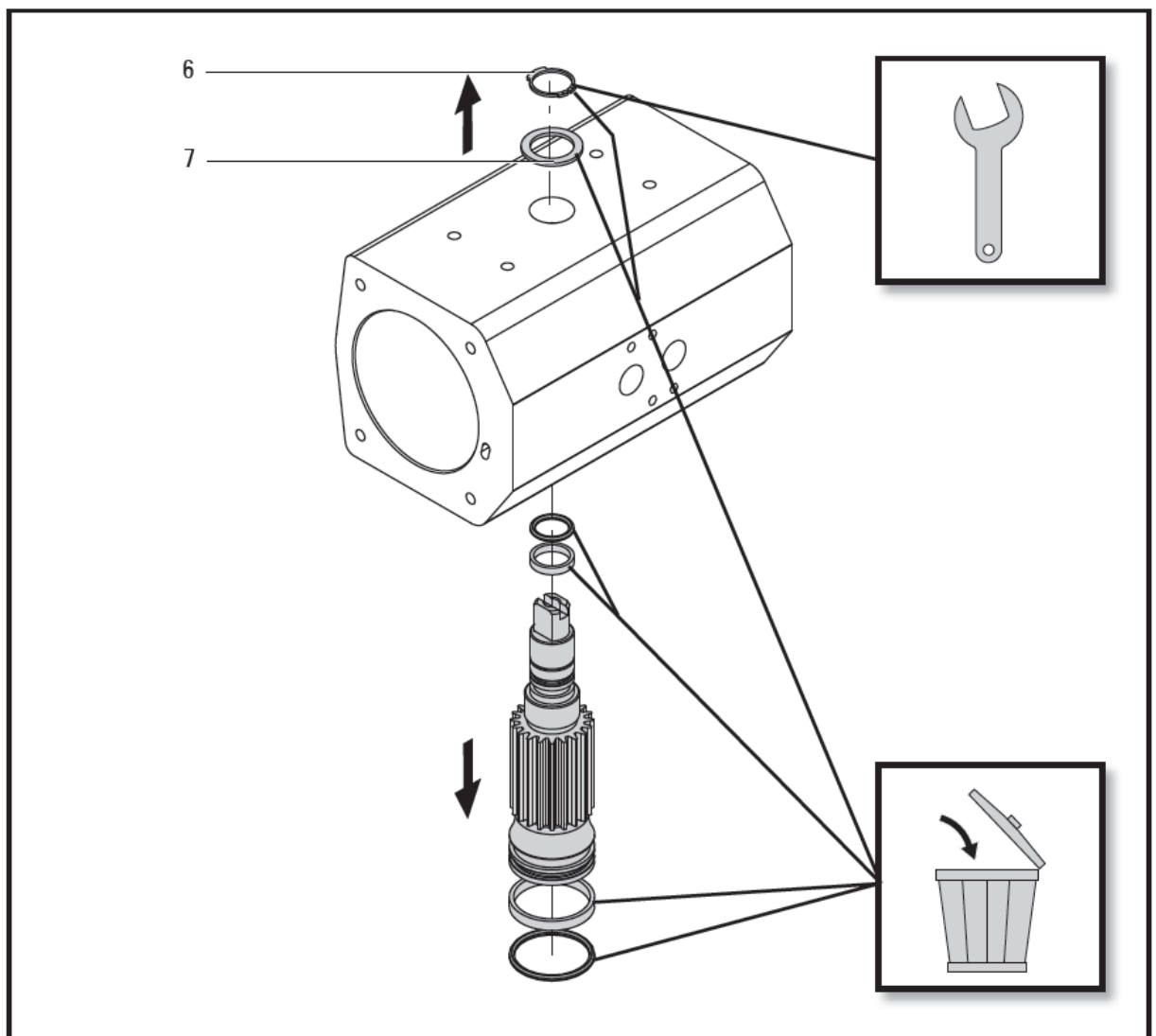

Maintenance - Mounting the spare parts kit

### Preparation

Clean all the parts thoroughly. Check, whether the treads of the actuator and all not replaced parts are undamaged.

Insert new sealings and guide rings. Observe that the parts are undamaged and that they are placed in a correct way.

Apply a light film of grease to all sealings and on the gear teeth by a grease recommended by Kobold.



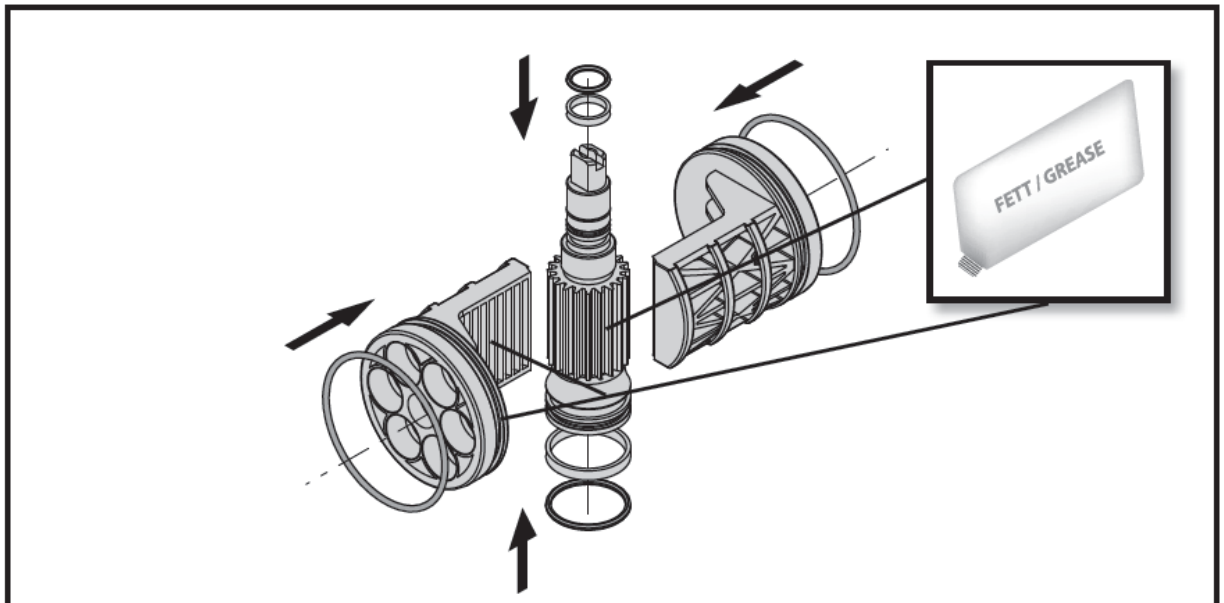

Maintenance - Mounting of the spare parts kit

## Mounting

Insert the shaft (1) from the bottom into the body (2) and push it in to the stop. Observe that no sealing and no guide ring will be damaged.

Push the bearing bush (3) over the top of the shaft. Mount the spring clip (4) in the groove of the shaft by fit tongs. Check the correct placement of the spring clip.

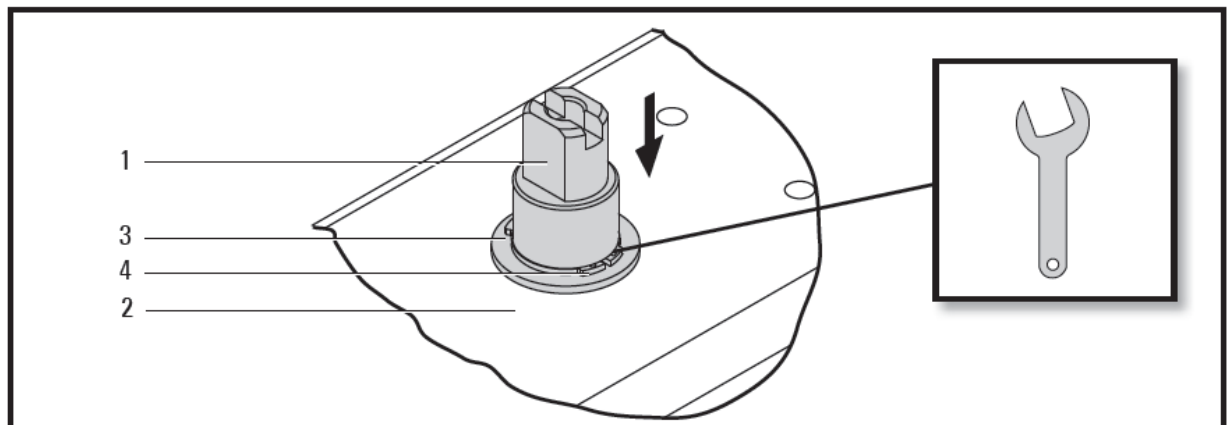

Maintenance - Mounting of the spare part kit

Insert the pistons (1) into the body. Observe the right position of the gear rack (2), because the gear rack influences the turning direction of the pneumatic actuator. See also chapter 7.2 Rotation direction.

Observe the right position of the piston seals (3).

Push the piston into the body, so that both gear racks will mesh into the teeth of the pinion at the same time. Observe the turning direction of the shaft.

After the gear racks had mesh the teeth of the pinion turn the shaft in the ascertained direction up to an angle of 90° by a spanner (see figure 11.5). The pistons have to strike against themselves and that the pistons have to be symmetrically in the body.

Put the new cap seals (4) into the sealing groove of the cap (5). Check the right placement of the seals.

Put the cap onto the body and align it. Screw in the bolts (6) with the washers(7) into the body and tighten them up crosswise.

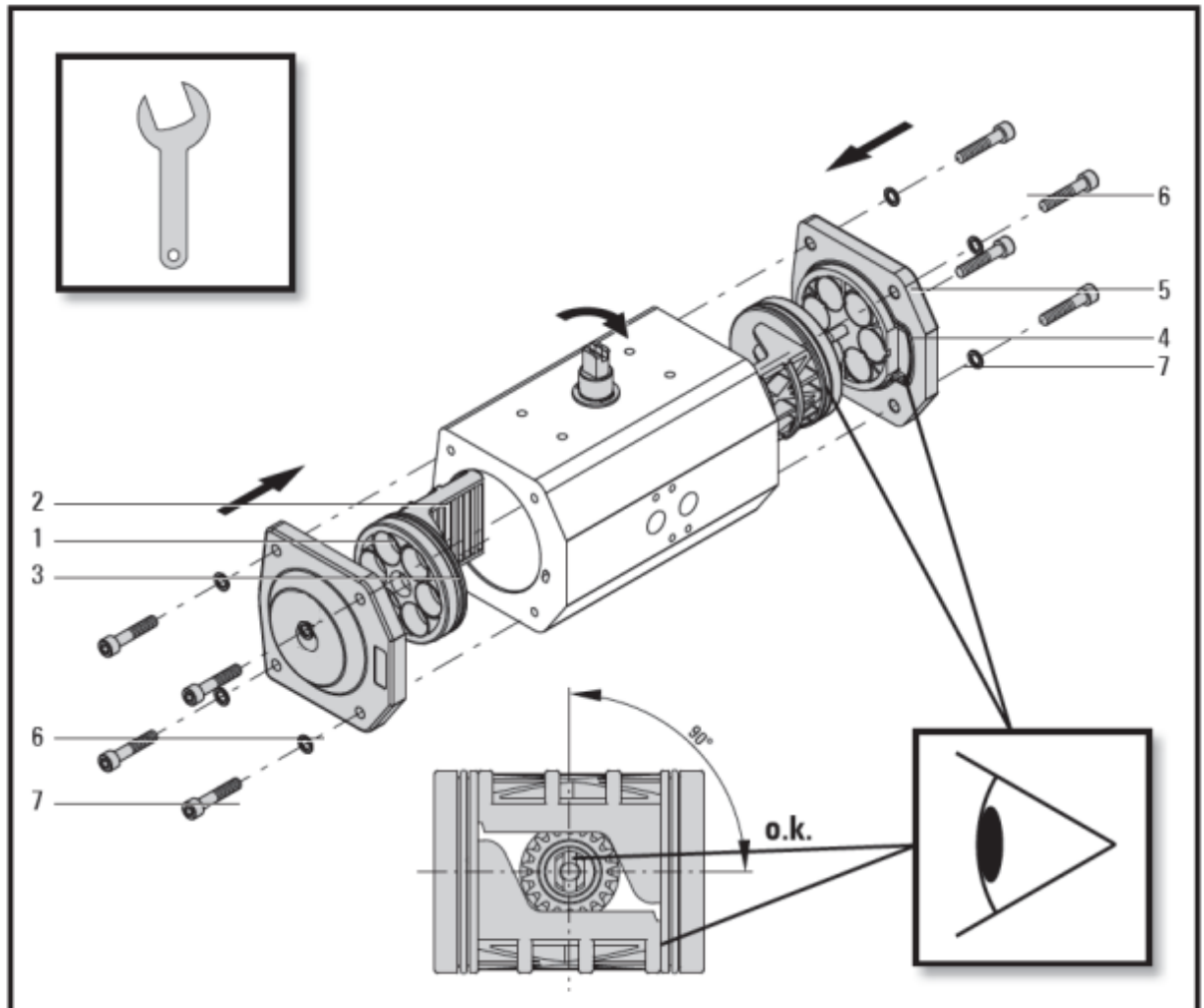

Maintenance - Mounting of the spare parts kit

Check the function and if necessary adjust the limit stops. See also chapter 10. Adjustment/Starting.

### 13.2.2. Mounting of the spare part kit at actuator KUP with function „single-acting“

At single-acting pneumatic actuators the replacement of the spare part kit will be permitted only by the manufacturer.

Don't loosen or screw out the cap bolts on no account. There will be a high tension at the caps causes by the resilience.

### **13.3. Cleaning**

Clean the body of the pneumatic actuator as required using a slightly moistened, soft cloth and a normal household cleaner.

Do not use any abrasive, corrosive or flammable cleaning agents!

Do not use any high-pressure cleaning devices!

Prevent moisture or liquid penetrating into the interior of the actuator!

## 14. Device Description

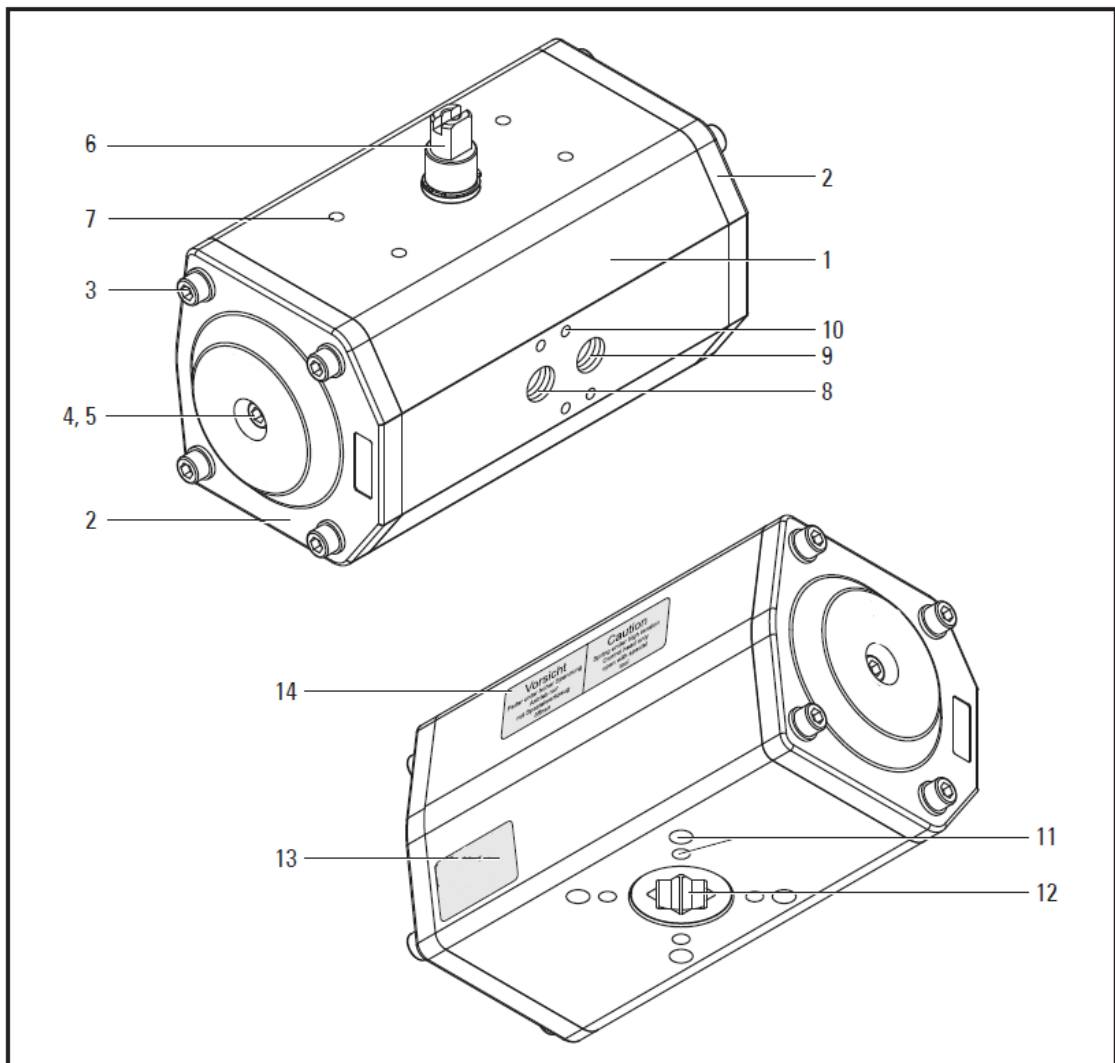

### Device description

- 1 body
- 2 cap
- 3 cap bolt
- 4 limit stop bolt
- 5 nut
- 6 shaft for signal devices
- 7 fastening thread for signal devices (M5 x 7)
- 8 pilot port P1
- 9 pilot port P2
- 10 fastening thread for control devices(M5 x 8)
- 11 fastening thread for slide/valve/ flap
- 12 shaft for slide/valve/flap
- 13 name-plate
- 14 warning notice (only for single acting actuators)

## **15. Technical details**

---

Operating instructions, data sheet, approvals and further information via the QR code on the device or via [www.kobold.com](http://www.kobold.com)

## **16. Order Codes**

---

Operating instructions, data sheet, approvals and further information via the QR code on the device or via [www.kobold.com](http://www.kobold.com)

## **17. Dimensions [mm]**

---

Operating instructions, data sheet, approvals and further information via the QR code on the device or via [www.kobold.com](http://www.kobold.com)

## 18. Disposal

---

### Note!

- Avoid environmental damage caused by media-contaminated parts
- Dispose of the device and packaging in an environmentally friendly manner
- Comply with applicable national and international disposal regulations and environmental regulations.

### Batteries

Batteries containing pollutants are marked with a sign consisting of a crossed-out garbage can and the chemical symbol (Cd, Hg, Li or Pb) of the heavy metal that is decisive for the classification as containing pollutants:

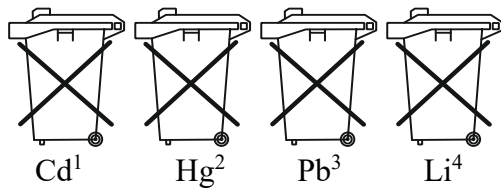

1. „Cd" stands for cadmium
2. „Hg" stands for mercury
3. „Pb" stands for lead
4. „Li" stands for lithium

### Electrical and electronic equipment

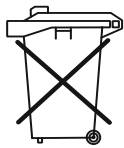

## 19. EC Declaration of Conformance

We, KOBOLD Messring GmbH, Hofheim-Ts, Germany, declare under our sole responsibility that the product:

**Ball valve with pneumatic actuator KUP-...**

to which this declaration relates is in conformity with the standards noted below:

### EN ISO 12100:2011-03

Safety of machinery - General principles for design - Risk assessment and risk reduction

Also, the following EC guidelines are fulfilled:

**2011/65/EU**                      **RoHS** (category 9)  
**2015/863/EU**                    Delegated Directive (RoHS III)

**As per 2014/68/EU PED** (Pressure Equipment Directive)

	Article 4 Paragraph (3), "Sound Engineering Practice", no CE mark	2014/68/EU PED, CE mark
KUP-KA, 1¼" ...3"		x
KUP-KA ½" ...1"	x	
KUP-ZA, 1¼" ...4", DN32...DN100		x
KUP-ZA, ¼" ...1", DN15...DN25	x	
KUP-VH, 1¼" ...2"		x
KUP-VH, ½" ...1"	x	
KUP-VN, 1¼" ...2"		x
KUP-VN, ½" ...1"	x	
KUP-PD, 1¼" ...2"		x
KUP-PD, ½" ...1"	x	
KUP-VO, DN32...DN200		x
KUP-VO, DN25	x	
KUP-VK, DN32...DN200		x
KUP-VK, DN15...DN25	x	

Additional for devices with solenoid valve:

**2014/35/EU**                      Low Voltage Directive  
**2014/30/EU**                      EMC Directive

**DIN EN ISO 12100:2011**

Safety of machinery - General principles for design - Risk assessment and risk reductionE

**DIN EN 60204-1:2014**

Safety of machinery - Electrical equipment of machines - Part 1: General requirements

Additional for devices with limit switches:

**2014/35/EU**                      Low Voltage Directive

**DIN EN 61058-1:2008**

Switches for appliances - Part 1: General requirements



H. Peters  
General Manager



M. Wenzel  
Proxy Holder

Hofheim, 15 Oct. 2019