



## Bourdon Tube Pressure Gauges

acc. to EN 837 · for industrial applications



measuring  
•  
monitoring  
•  
analysing

### MAN-R/MAN-Q



- Housing:  
63 mm, 80 mm, 100 mm, 160 mm  
Rectangular casing:  
96 x 96 mm, 144 x 144 mm  
Options:  
40 mm, 50 mm, 250 mm, 400 mm
- Connection:  
G $\frac{1}{4}$  (63, 80 mm housing)  
G $\frac{1}{2}$  (100, 160 mm housing)
- Material  
Housing: stainless steel, steel,  
aluminium  
Connection: brass
- Measuring ranges:  
-1 ... 0 bar ... 0 ... +1000 bar
- Options: liquid filling;  
contacts; transmitter



P1

KOBOLD companies worldwide:

AUSTRALIA, AUSTRIA, BELGIUM, BULGARIA, CANADA, CHINA, CZECHIA, FRANCE, GERMANY, GREAT BRITAIN, HUNGARY, INDIA, INDONESIA, ITALY, MALAYSIA, MEXICO, NETHERLANDS, PERU, POLAND, REPUBLIC OF KOREA, SPAIN, SWITZERLAND, THAILAND, TUNISIA, TURKEY, USA, VIETNAM

KOBOLD Messring GmbH  
Nordring 22-24  
D-65719 Hofheim/Ts.  
Head Office:  
+49(0)6192 299-0  
+49(0)6192 23398  
info.de@kobold.com  
www.kobold.com



### Application

These KOBOLD pressure gauges can be used for all applications where accuracy, repeatability and long-term stability are of special importance. They can be used for liquid or gaseous substances which do not crystallize, are not highly viscous and do not corrode brass.

The extensive range of options allows the user to adapt the instruments to his own special requirements. All the pressure gauges comply with general international guidelines and take account of standard as well as application-specific requirements. KOBOLD Bourdon tube pressure gauges are the result of over 70 years experience in building pressure gauges.

### Measuring Principle

Mechanical pressure measurement uses the principle of an elastic measuring element, which generates a precisely defined, reproducible deflection when subjected to pressure. The motion works convert this into a rotary motion of the pointer. The pressure at the measuring element can be read on the scale of the dial.

### Housing

The following housing diameters are available: 63 mm, 80 mm, 100 mm and 160 mm. The housing is made of stainless steel. As an alternative to the 100 mm or 160 mm diameter pressure gauge, the devices can also be supplied with a robust aluminium housing. This option is only available from KOBOLD and has proven ideal for very robust use in filled equipment, e.g. in ship's diesel engines. It is also available with a rectangular profile housing for integration into control panels. This is available as 96 x 96 mm and 144 x 144 mm versions. Housings are optionally available with 40 mm, 50 mm, 250 mm or 400 mm nominal diameters.

### Unifilar Drawing

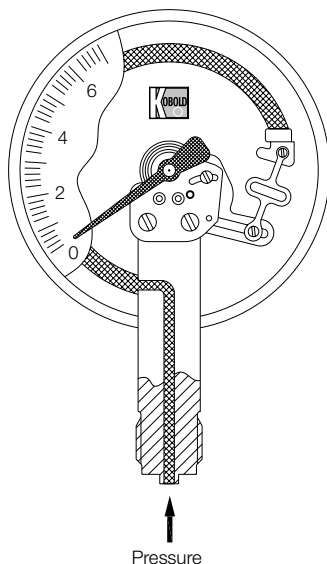

### Installation

The gauges are most often installed straight into the customer's screw necks. Optional gauge models with an installation border on the front are also available for installation into or onto control panels.

### Connection

The gauges with 63 and 80 mm housing diameter are supplied with a G ¼ connecting thread as standard, gauges with housing diameter of 100 mm and above with G ½ connecting thread. The connection is made of brass. Diaphragm seals can be mounted for viscous, crystallising, aggressive materials or higher temperature materials to prevent the material being measured from penetrating into the measuring system. Other connection types are available on request.

### Measuring Ranges

The measuring ranges are graduated according to DIN recommendations and lie between -1...0 bar and 0...1000 bar. Other scales with measuring ranges in PSI, Pa or with your company logo are available on request.

### Damping Liquid

Pressure gauges with liquid filling are used in locations with high alternating dynamic loads, strong vibrations and pulses. The filling ensures easy readability through steady pointer movement even when subjected to extreme loading and heavy vibration. The lubricating effect of the glycerine also keeps wear to a minimum. Glycerine is always used as a matter of principle. In gauges with a contact or an electrical measuring transducer, liquid paraffin is used as a non-conductive alternative. Silicone fillings of various viscosities are also optionally available.

### Contacts





For monitoring the system pressure, gauges with 100 mm or 160 mm diameter can be fitted with up to four limit contacts. Slow action, magnetic spring, inductive and pneumatic contacts are also available (see data sheet »Contact Fittings for Pressure Gauges« MAN-..S/M/I/P).

### Fields of Application

- Mechanical engineering
- Hydraulics
- Compressors
- Pumps
- Plant construction







**Technical Details · NG 63/80, Rectangular Casing**

| Connection/Housing  | Round housing   |                        |  | Profile housing                    |             |             |
|---|---|------------------------|--|------------------------------------|-------------|-------------|
|   | NG 63   | NG 63                  | NG 80  | 96x96                              | 144x144     |             |
| <b>Model</b>  |   |                        |  |                                    |             |             |
| Bottom connection                                  | MAN-...   | ...RD21...             | ...RD71...   | ...RE22...                         | -           | -           |
| Back connection                                    | MAN-...   | ...RD23...<br>central  | ...RD73...<br>central  | ...RE24...<br>eccentric            | -           | -           |
| Triangular front ring with clamp, Back connection  | MAN-...   | ...RD23B...<br>central | ...RD73B...<br>central                                       | ...RE24K...<br>eccentric           | ...QF14B... | ...QG14B... |
| Front flange<br>Back connection                    | MAN-...   | ...RD23V...<br>central | ...RD73V...<br>central                                       | ...RE24V...<br>eccentric           | -           | -           |
| Accuracy class  | 1.6   |                        |  |                                    |             |             |
| Housing version   | stainless steel 1.4301  |                        |  | steel, nickel plated               |             |             |
| Filling   | -   | glycerine              | -  | -                                  | -           |             |
| Ring/housing  | stainless steel 1.4301  |                        |  | light metal / steel, nickel plated |             |             |
| Pointer   | aluminium, black anodized, partly plastic   |                        |  | aluminium, black anodized          |             |             |
| Movement  | brass   |                        |  |                                    |             |             |
| Throttle  | from 60 bar D = 0.5 mm  |                        |  |                                    |             |             |
| Window  | polycarbonate   |                        | instrument glass   |                                    |             |             |
| Measuring element   | CuSn (from 100 bar stainless steel 1.4571)  |                        |  |                                    |             |             |
| Protection  | IP 65   | IP 67                  | IP 65  | IP 54 from ahead                   |             |             |
| Overrange protection  | 1.2 times   |                        | short-term 1.3 times (from 1000 bar 1.1 times) of full scale |                                    |             |             |
| Weight  | siehe Tabelle   |                        | 0.4 kg   | 0.7 kg                             | 1.2 kg      |             |
| Ambient temperature   | -20...+60°C   |                        |  |                                    |             |             |
| Connection  | brass   |                        |  |                                    |             |             |
| Thread connection   | G ¼ male  |                        |  | G ½ male                           |             |             |
| Max. medium temperature   | 80°C  |                        |  |                                    |             |             |
| Contacts  | no  |                        |  | yes, max. 4 contacts               |             |             |
| Options   | Trailing pointer, marking pointer, oil-free and decreased, special scale, dual scale bar + psi ex stock |                        |  |                                    |             |             |
| <b>Indicating range</b>   | <b>Code of indicating range</b>   |                        |  |                                    |             |             |
| -0.6...0 bar  | -   | -                      | ..AC   | ..AC                               | ..AC        |             |
| -1...0 bar  | ..AD  | ..AD                   | ..AD   | ..AD                               | ..AD        |             |
| -1...+0.6 bar   | ..A0  | ..A0                   | ..A0   | ..A0                               | ..A0        |             |
| -1...+1.5 bar   | ..A1  | ..A1                   | ..A1   | ..A1                               | ..A1        |             |
| -1...+3 bar   | ..A2  | ..A2                   | ..A2   | ..A2                               | ..A2        |             |
| -1...+5 bar   | ..A3  | ..A3                   | ..A3   | ..A3                               | ..A3        |             |
| -1...+9 bar   | ..A4  | ..A4                   | ..A4   | ..A4                               | ..A4        |             |
| -1...+15 bar  | ..A5  | ..A5                   | ..A5   | ..A5                               | ..A5        |             |
| 0...0.6 bar   | -   | -                      | -  | ..B1                               | ..B1        |             |
| 0...1 bar   | ..B2  | ..B2                   | ..B2   | ..B2                               | ..B2        |             |
| 0...1.6 bar   | ..B3  | ..B3                   | ..B3   | ..B3                               | ..B3        |             |
| 0...2.5 bar   | ..B4  | ..B4                   | ..B4   | ..B4                               | ..B4        |             |
| 0...4 bar   | ..B5  | ..B5                   | ..B5   | ..B5                               | ..B5        |             |
| 0...6 bar   | ..B6  | ..B6                   | ..B6   | ..B6                               | ..B6        |             |
| 0...10 bar  | ..B7  | ..B7                   | ..B7   | ..B7                               | ..B7        |             |
| 0...16 bar  | ..B8  | ..B8                   | ..B8   | ..B8                               | ..B8        |             |
| 0...25 bar  | ..B9  | ..B9                   | ..B9   | ..B9                               | ..B9        |             |
| 0...40 bar  | ..B0  | ..B0                   | ..B0   | ..B0                               | ..B0        |             |
| 0...60 bar  | ..C1  | ..C1                   | ..C1   | ..C1                               | ..C1        |             |
| 0...100 bar   | ..C2  | ..C2                   | ..C2   | ..C2                               | ..C2        |             |
| 0...160 bar   | ..C3  | ..C3                   | ..C3   | ..C3                               | ..C3        |             |
| 0...250 bar   | ..C4  | ..C4                   | ..C4   | ..C4                               | ..C4        |             |
| 0...400 bar   | ..C5  | ..C5                   | ..C5   | ..C5                               | ..C5        |             |
| 0...600 bar   | ..C6  | ..C6                   | ..C6   | ..C6                               | ..C6        |             |
| 0...1000 bar  | -   | -                      | -  | ..D7                               | ..D7        |             |







**Technical Details · NG 100**

| Connection/Housing  |  | Model                    |                          |                          |                          |
|---|--|--------------------------|--------------------------|--------------------------|--------------------------|
| Bottom connection                                  | MAN-...  | ...RF22...               | ...RF32...               | ...RF72...               | ...RF62...               |
| Back connection                                    | MAN-...  | ...RF24...<br>eccentric  | ...RF34...<br>eccentric  | ...RF74...<br>eccentric  | ...RF64...<br>eccentric  |
| Triangular front ring with clamp, back connection  | MAN-...  | ...RF24K...<br>eccentric | ...RF34K...<br>eccentric | -                        | ...RF64K...<br>eccentric |
| Front flange<br>Back connection                    | MAN-...  | ...RF24V...<br>eccentric | ...RF34V...<br>eccentric | ...RF74V...<br>eccentric | ...RF64V...<br>eccentric |
| Accuracy class  | 1.0  |                          |                          |                          |                          |
| Housing version   | stainless steel 1.4301   | aluminium                | stainless steel 1.4301   | aluminium                |                          |
| Filling   | -  |                          |                          |                          |                          |
| Ring  | stainless steel 1.4301   | steel black              | stainless steel 1.4301   | steel black              |                          |
| Pointer   | aluminium, black anodized  |                          |                          |                          |                          |
| Movement  | brass  |                          |                          |                          |                          |
| Throttle  | from 60 bar D = 0.5 mm   |                          |                          |                          |                          |
| Window  | instrument glass   |                          |                          |                          |                          |
| Measuring element   | CuSn (from 100 bar stainless steel 1.4571)                               |                          |                          |                          |                          |
| Protection  | IP 65  |                          | IP 67                    |                          |                          |
| Overrange protection  | short-term 1.3 times (from 1000 bar 1.1 times) of full scale             |                          |                          |                          |                          |
| Weight  | see table  |                          |                          |                          |                          |
| Ambient temperature   | -20 ... +60 °C   |                          |                          |                          |                          |
| Connection  | brass  |                          |                          |                          |                          |
| Thread connection   | G ½ male   |                          |                          |                          |                          |
| Max. medium temperature   | 80 °C  |                          |                          |                          |                          |
| Contacts  | max. 3   | max. 4                   | max. 3                   | max. 4                   |                          |
| Options   | Trailing pointer, marking pointer, oil-free and decreased, special scale |                          |                          |                          |                          |
| <b>Indicating range</b>   | <b>Code of indicating range</b>  |                          |                          |                          |                          |
| -0.6 ... 0 bar  | ..AC   | ..AC                     | ..AC                     | ..AC                     |                          |
| -1 ... 0 bar  | ..AD   | ..AD                     | ..AD                     | ..AD                     |                          |
| -1 ... +0.6 bar   | ..A0   | ..A0                     | ..A0                     | ..A0                     |                          |
| -1 ... +1.5 bar   | ..A1   | ..A1                     | ..A1                     | ..A1                     |                          |
| -1 ... +3 bar   | ..A2   | ..A2                     | ..A2                     | ..A2                     |                          |
| -1 ... +5 bar   | ..A3   | ..A3                     | ..A3                     | ..A3                     |                          |
| -1 ... +9 bar   | ..A4   | ..A4                     | ..A4                     | ..A4                     |                          |
| -1 ... +15 bar  | ..A5   | ..A5                     | ..A5                     | ..A5                     |                          |
| 0 ... 0.6 bar   | ..B1   | ..B1                     | ..B1                     | ..B1                     |                          |
| 0 ... 1 bar   | ..B2   | ..B2                     | ..B2                     | ..B2                     |                          |
| 0 ... 1.6 bar   | ..B3   | ..B3                     | ..B3                     | ..B3                     |                          |
| 0 ... 2.5 bar   | ..B4   | ..B4                     | ..B4                     | ..B4                     |                          |
| 0 ... 4 bar   | ..B5   | ..B5                     | ..B5                     | ..B5                     |                          |
| 0 ... 6 bar   | ..B6   | ..B6                     | ..B6                     | ..B6                     |                          |
| 0 ... 10 bar  | ..B7   | ..B7                     | ..B7                     | ..B7                     |                          |
| 0 ... 16 bar  | ..B8   | ..B8                     | ..B8                     | ..B8                     |                          |
| 0 ... 25 bar  | ..B9   | ..B9                     | ..B9                     | ..B9                     |                          |
| 0 ... 40 bar  | ..B0   | ..B0                     | ..B0                     | ..B0                     |                          |
| 0 ... 60 bar  | ..C1   | ..C1                     | ..C1                     | ..C1                     |                          |
| 0 ... 100 bar   | ..C2   | ..C2                     | ..C2                     | ..C2                     |                          |
| 0 ... 160 bar   | ..C3   | ..C3                     | ..C3                     | ..C3                     |                          |
| 0 ... 250 bar   | ..C4   | ..C4                     | ..C4                     | ..C4                     |                          |
| 0 ... 400 bar   | ..C5   | ..C5                     | ..C5                     | ..C5                     |                          |
| 0 ... 600 bar   | ..C6   | ..C6                     | ..C6                     | ..C6                     |                          |
| 0 ... 1000 bar  | ..D7   | ..D7                     | ..D7                     | ..D7                     |                          |



**Technical Details · NG 160**

| Connection/Housing   |  | Model                    |                                    |                          |                          |
|--|--|--------------------------|------------------------------------|--------------------------|--------------------------|
| Bottom connection                                 | MAN-...  | ...RG22...               | ...RG32...                         | ...RG72...               | ...RG62...               |
| Back connection                                   | MAN-...  | ...RG24...<br>eccentric  | ...RG34...<br>eccentric            | ...RG74...<br>eccentric  | ...RG64...<br>eccentric  |
| Triangular front ring and clamp, back connection  | MAN-...  | -                        | ...RG34K...<br>eccentric           | -                        | ...RG64K...<br>eccentric |
| Front flange<br>Back connection                   | MAN-...  | ...RG24V...<br>eccentric | ...RG34V...<br>eccentric           | ...RG74V...<br>eccentric | ...RG64V...<br>eccentric |
| Accuracy class   | 1.0  |                          |                                    |                          |                          |
| Housing version  | stainless steel 1.4301   | aluminium                | stainless steel 1.4301             | aluminium                |                          |
| Filling  | -  |                          | glycerine (paraffine with contact) |                          |                          |
| Ring   | stainless steel 1.4301   | steel black              | stainless steel 1.4301             | steel black              |                          |
| Pointer  | aluminium, black anodized  |                          |                                    |                          |                          |
| Movement   | brass  |                          |                                    |                          |                          |
| Throttle   | from 60 bar D = 0.5 mm   |                          |                                    |                          |                          |
| Window   | instrument glass   |                          |                                    |                          |                          |
| Measuring element  | CuSn (from 100 bar stainless steel 1.4571)                               |                          |                                    |                          |                          |
| Protection   | IP 65  |                          | IP 67                              |                          |                          |
| Overrange protection   | short-term 1.3 times (from 1000 bar 1.1 times) of full scale             |                          |                                    |                          |                          |
| Weight   | see table  |                          |                                    |                          |                          |
| Ambient temperature  | -20 ... +60 °C   |                          |                                    |                          |                          |
| Connection   | brass  |                          |                                    |                          |                          |
| Thread connection  | G ½ male   |                          |                                    |                          |                          |
| Max. medium temperature  | 80 °C  |                          |                                    |                          |                          |
| Contacts   | max. 3   | max. 4                   | max. 3                             | max. 4                   |                          |
| Options  | Trailing pointer, marking pointer, oil-free and decreased, special scale |                          |                                    |                          |                          |
| <b>Indicating range</b>  | <b>Code of indicating range</b>  |                          |                                    |                          |                          |
| -0.6 ... 0 bar   | ..AC   | ..AC                     | ..AC                               | ..AC                     |                          |
| -1 ... 0 bar   | ..AD   | ..AD                     | ..AD                               | ..AD                     |                          |
| -1 ... +0.6 bar  | ..A0   | ..A0                     | ..A0                               | ..A0                     |                          |
| -1 ... +1.5 bar  | ..A1   | ..A1                     | ..A1                               | ..A1                     |                          |
| -1 ... +3 bar  | ..A2   | ..A2                     | ..A2                               | ..A2                     |                          |
| -1 ... +5 bar  | ..A3   | ..A3                     | ..A3                               | ..A3                     |                          |
| -1 ... +9 bar  | ..A4   | ..A4                     | ..A4                               | ..A4                     |                          |
| -1 ... +15 bar   | ..A5   | ..A5                     | ..A5                               | ..A5                     |                          |
| 0 ... 0.6 bar  | ..B1   | ..B1                     | ..B1                               | ..B1                     |                          |
| 0 ... 1 bar  | ..B2   | ..B2                     | ..B2                               | ..B2                     |                          |
| 0 ... 1.6 bar  | ..B3   | ..B3                     | ..B3                               | ..B3                     |                          |
| 0 ... 2.5 bar  | ..B4   | ..B4                     | ..B4                               | ..B4                     |                          |
| 0 ... 4 bar  | ..B5   | ..B5                     | ..B5                               | ..B5                     |                          |
| 0 ... 6 bar  | ..B6   | ..B6                     | ..B6                               | ..B6                     |                          |
| 0 ... 10 bar   | ..B7   | ..B7                     | ..B7                               | ..B7                     |                          |
| 0 ... 16 bar   | ..B8   | ..B8                     | ..B8                               | ..B8                     |                          |
| 0 ... 25 bar   | ..B9   | ..B9                     | ..B9                               | ..B9                     |                          |
| 0 ... 40 bar   | ..B0   | ..B0                     | ..B0                               | ..B0                     |                          |
| 0 ... 60 bar   | ..C1   | ..C1                     | ..C1                               | ..C1                     |                          |
| 0 ... 100 bar  | ..C2   | ..C2                     | ..C2                               | ..C2                     |                          |
| 0 ... 160 bar  | ..C3   | ..C3                     | ..C3                               | ..C3                     |                          |
| 0 ... 250 bar  | ..C4   | ..C4                     | ..C4                               | ..C4                     |                          |
| 0 ... 400 bar  | ..C5   | ..C5                     | ..C5                               | ..C5                     |                          |
| 0 ... 600 bar  | ..C6   | ..C6                     | ..C6                               | ..C6                     |                          |
| 0 ... 1000 bar   | ..D7   | ..D7                     | ..D7                               | ..D7                     |                          |



**Dimensions**

**Bottom connection**

| Code         | NG         | A  | B               |                 |            |            | C    | d   | D   | E    | AF | W   | X   |
|--------------|------------|----|-----------------|-----------------|------------|------------|------|-----|-----|------|----|-----|-----|
|              |            |    | without contact | 1 or 2 contacts | 3 contacts | 4 contacts |      |     |     |      |    |     |     |
| MAN-RD 21/71 | 63 mm      | 6  | 31              | -               | -          | -          | 13   | 52  | 68  | 55   | 14 | -   | -   |
| MAN-RE 22    | 80 mm      | 5  | 43.5            | -               | -          | -          | 16   | 80  | 84  | 76   | 22 | -   | -   |
| MAN-RF 22/72 | 100 mm VA  | 17 | 48              | 82              | 97         | 110        | 15   | 100 | 101 | 86.5 | 22 | 0   | 88  |
| MAN-RF 32/62 | 100 mm Alu | -  | 43              | 91              | 107        | 107        | 15   | 100 | -   | 86.5 | 27 | 0   | 88  |
| MAN-RG 22/72 | 160 mm VA  | 21 | 50              | 101             | 120        | 120        | 15   | 159 | 162 | 117  | 22 | 0   | 118 |
| MAN-RG 32/62 | 160 mm Alu | -  | 48              | 101             | 127        | 127        | 18.5 | 160 | -   | 115  | 27 | 25° | 118 |

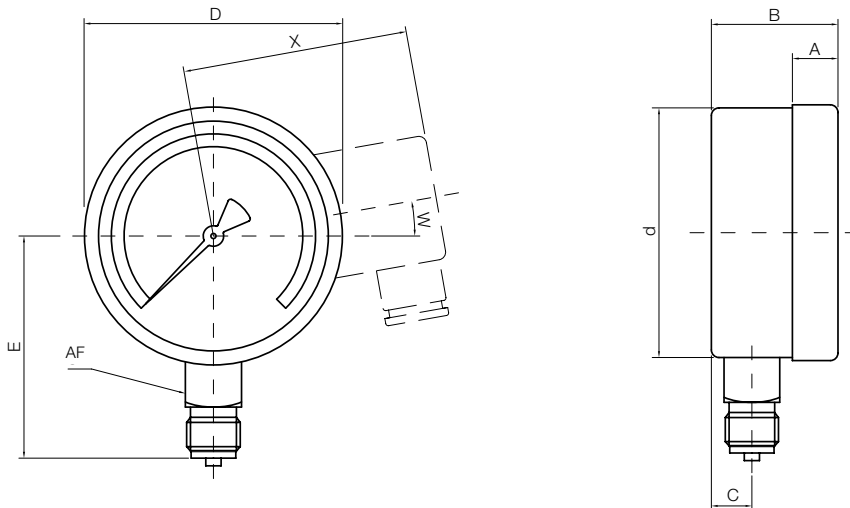

**Back connection**

| Code         | NG         | A  | B               |                 |            |            | C  | d   | D   | E    | AF | W   | X   |
|--------------|------------|----|-----------------|-----------------|------------|------------|----|-----|-----|------|----|-----|-----|
|              |            |    | without contact | 1 or 2 contacts | 3 contacts | 4 contacts |    |     |     |      |    |     |     |
| MAN-RD 23/73 | 63 mm      | 6  | 28              | -               | -          | -          | 26 | 63  | 68  | 0    | 14 | -   | -   |
| MAN-RE 24    | 80 mm      | 5  | 43.5            | -               | -          | -          | 35 | 80  | 84  | 0    | 22 | -   | -   |
| MAN-RF 24/74 | 100 mm VA  | 17 | 49              | 82              | 97         | 110        | 36 | 100 | 101 | 32.5 | 17 | 0   | 88  |
| MAN-RF 34/64 | 100 mm Alu | -  | 43              | 91              | 107        | 107        | 34 | 100 | -   | 32.5 | 27 | 0   | 88  |
| MAN-RG 24/74 | 160 mm VA  | 21 | 50              | 101             | 120        | 120        | 34 | 159 | 162 | 32.5 | 17 | 0   | 118 |
| MAN-RG 34/64 | 160 mm Alu | -  | 48              | 101             | 127        | 127        | 30 | 160 | -   | 50   | 27 | 25° | 118 |

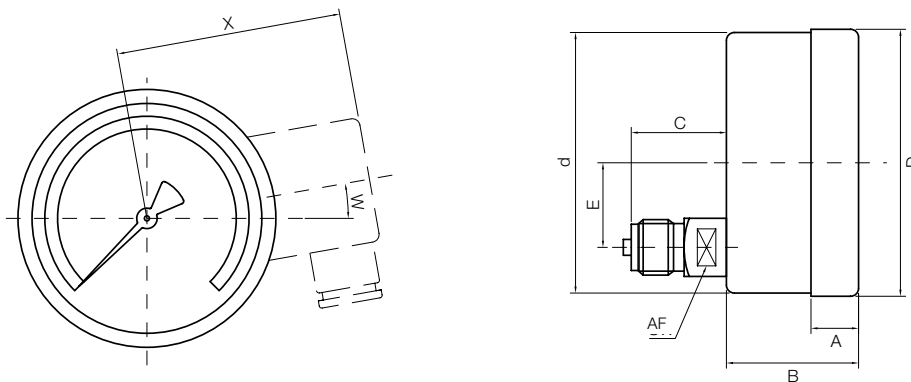

**Dimensions**

**Triangular front ring with clamp**

| Code           | NG         | A | B<br>without<br>contact | B<br>1 or 2<br>contacts | B<br>3<br>contacts | B<br>4<br>contacts | C  | d   | D   | E    | AF | W | X  |
|----------------|------------|---|-------------------------|-------------------------|--------------------|--------------------|----|-----|-----|------|----|---|----|
| MAN-RD 23/73 B | 63 mm      | 6 | 26                      | -                       | -                  | -                  | 26 | 62  | 68  | 0    | 14 | - | -  |
| MAN-RE 24 K    | 80 mm      | 5 | 43.5                    | -                       | -                  | -                  | 35 | 80  | 84  | 0    | 22 | - | -  |
| MAN-RF 24 K    | 100 mm VA  | 5 | 41                      | 88                      | 105                | 105                | 36 | 101 | 107 | 32.5 | 17 | 0 | 42 |
| MAN-RF 34/64 K | 100 mm Alu | 5 | 41                      | 88                      | 105                | 105                | 34 | 100 | 107 | 32.5 | 27 | 0 | 42 |
| MAN-RG 34/64 K | 160 mm VA  | 5 | 45                      | 98                      | 145                | 145                | 30 | 160 | 162 | 50   | 22 | 0 | 42 |

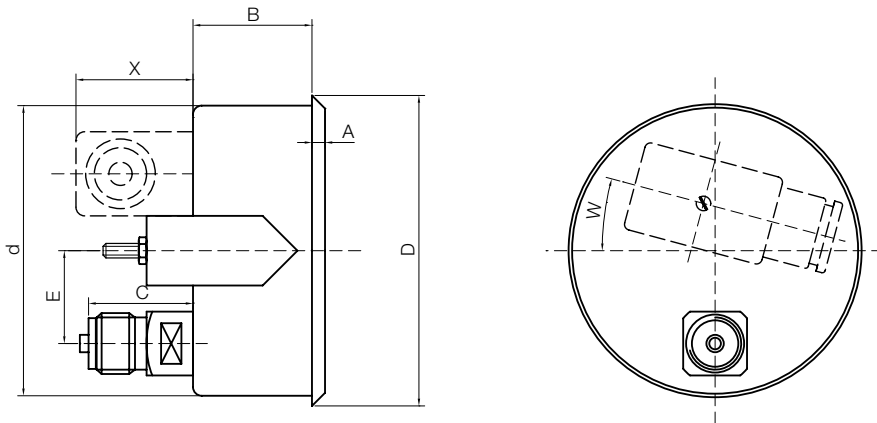

**Front flange**

| Code           | NG         | A | B<br>without<br>contact | B<br>1 or 2<br>contacts | B<br>3<br>contacts | B<br>4<br>contacts | C  | d   | D   | E    | LK  | S | AF | W  | X  |
|----------------|------------|---|-------------------------|-------------------------|--------------------|--------------------|----|-----|-----|------|-----|---|----|----|----|
| MAN-RD 23/73 V | 63 mm      | 7 | 24                      | -                       | -                  | -                  | 26 | 62  | 68  | 0    | 75  | 1 | 14 | -  | -  |
| MAN-RF 24/74 V | 100 mm VA  | 6 | 43                      | 86                      | 92                 | 105                | 36 | 104 | 101 | 32.5 | 116 | 2 | 17 | 15 | 42 |
| MAN-RF 34/64 V | 100 mm Alu | 5 | 40                      | 86                      | 102                | 102                | 34 | 100 | 100 | 32.5 | 116 | 2 | 27 | 15 | 42 |
| MAN-RG 24/74 V | 160 mm VA  | 6 | 43                      | 95                      | 110                | 110                | 34 | 164 | 161 | 32.5 | 178 | 2 | 17 | 15 | 42 |
| MAN-RG 34/64 V | 160 mm Alu | 9 | 42                      | 93                      | 118                | 118                | 30 | 160 | 160 | 50   | 178 | 2 | 27 | 15 | 42 |

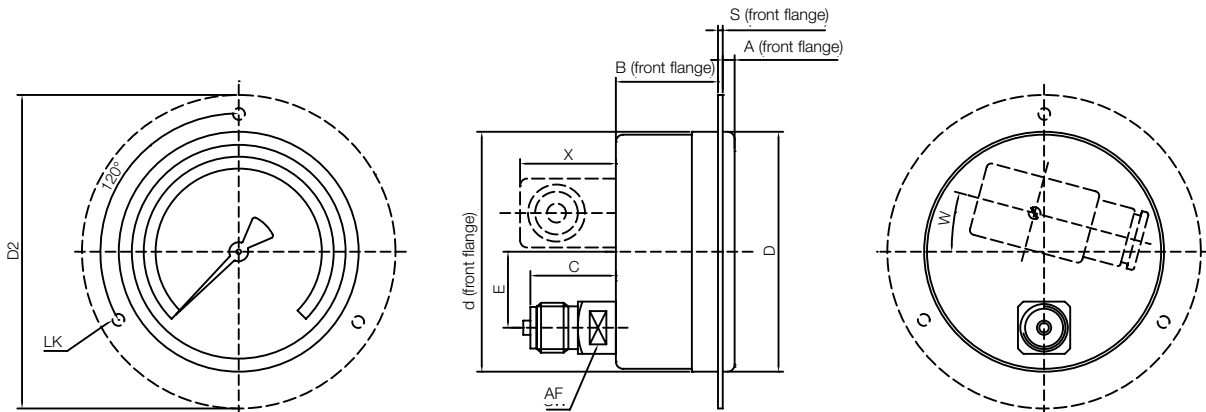

**Dimensions**

**Rectangular casing**

| Code   | NG        | A | B<br>without<br>contact | B<br>1 or 2<br>contacts | B<br>3<br>contacts | B<br>4<br>contacts | C  | d   | D   | E  | AF | X  |
|--------|-----------|---|-------------------------|-------------------------|--------------------|--------------------|----|-----|-----|----|----|----|
| MAN-QF | 96 x 96   | 9 | 40                      | 81                      | 85                 | 92                 | 34 | 90  | 96  | 32 | 17 | 42 |
| MAN-QG | 144 x 144 | 9 | 47                      | 90                      | 97                 | 127                | 34 | 135 | 144 | 32 | 17 | 42 |

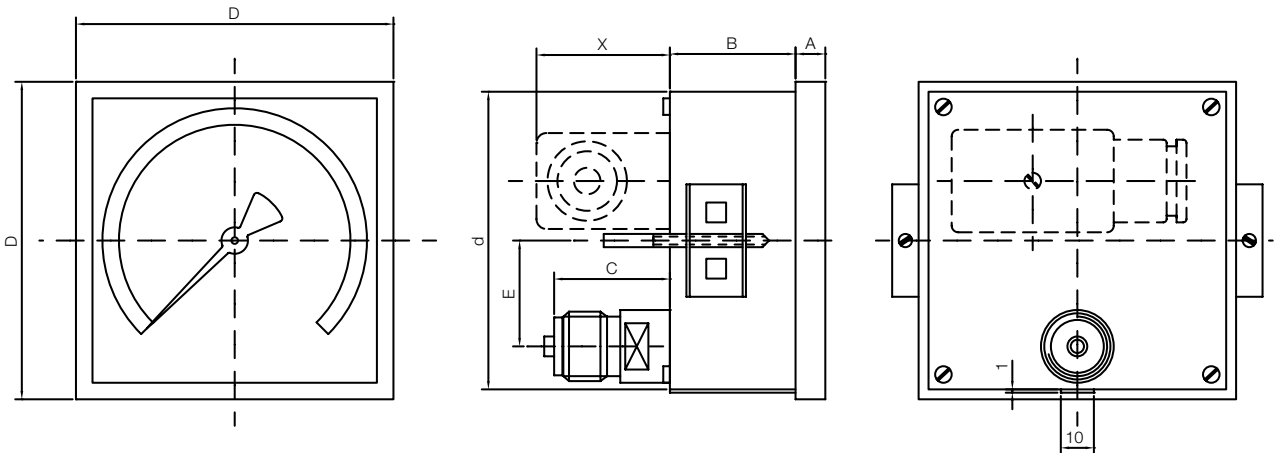

**Weight**

| NG 63       |                    | without<br>contact | up to 2<br>contacts | 3<br>contacts  | 4<br>contacts  |
|-------------|--------------------|--------------------|---------------------|----------------|----------------|
| Code        | Housing<br>filling | Weight<br>[kg]     | Weight<br>[kg]      | Weight<br>[kg] | Weight<br>[kg] |
| MAN-RD 21   | without            | 0.14               | -                   | -              | -              |
| MAN-RD 23   | without            | 0.15               | -                   | -              | -              |
| MAN-RD 23 B | without            | 0.18               | -                   | -              | -              |
| MAN-RD 23 V | without            | 0.18               | -                   | -              | -              |
| MAN-RD 71   | with               | 0.21               | -                   | -              | -              |
| MAN-RD 73   | with               | 0.22               | -                   | -              | -              |
| MAN-RD 73 B | with               | 0.25               | -                   | -              | -              |
| MAN-RD 73 V | with               | 0.25               | -                   | -              | -              |

| NG 80       |         |      |   |   |   |
|-------------|---------|------|---|---|---|
| MAN-RE 22   | without | 0.4  | - | - | - |
| MAN-RE 24   | without | 0.4  | - | - | - |
| MAN-RE 24 K | without | 0.4  | - | - | - |
| MAN-RE 24 V | without | 0.4  | - | - | - |
| MAN-RE 72   | with    | 0.55 | - | - | - |
| MAN-RE 74   | with    | 0.55 | - | - | - |
| MAN-RE 74 K | with    | 0.55 | - | - | - |
| MAN-RE 74 V | with    | 0.55 | - | - | - |

| NG 100      |         |     |     |      |     |
|-------------|---------|-----|-----|------|-----|
| MAN-RF 22   | without | 0.5 | 0.7 | 0.75 | 0.8 |
| MAN-RF 24   | without | 0.5 | 0.7 | 0.75 | 0.8 |
| MAN-RF 24 K | without | 0.6 | 0.8 | 0.85 | 0.9 |
| MAN-RF 24 V | without | 0.6 | 0.8 | 0.85 | 0.9 |
| MAN-RF 32   | without | 0.6 | 0.8 | 0.85 | 0.9 |
| MAN-RF 34   | without | 0.7 | 0.9 | 0.95 | 1.0 |
| MAN-RF 34 K | without | 0.7 | 0.9 | 0.95 | 1.0 |
| MAN-RF 34 V | without | 0.7 | 0.9 | 0.95 | 1.0 |

**Weight (continued)**

| NG 100      |                    | without<br>contact | up to 2<br>contacts | 3<br>contacts  | 4<br>contacts  |
|-------------|--------------------|--------------------|---------------------|----------------|----------------|
| Code        | Housing<br>filling | Weight<br>[kg]     | Weight<br>[kg]      | Weight<br>[kg] | Weight<br>[kg] |
| MAN-RF 62   | with               | 0.9                | 1.3                 | 1.4            | 1.5            |
| MAN-RF 64   | with               | 1.0                | 1.4                 | 1.5            | 1.6            |
| MAN-RF 64 K | with               | 1.0                | 1.4                 | 1.5            | 1.6            |
| MAN-RF 64 V | with               | 1.0                | 1.4                 | 1.5            | 1.6            |
| MAN-RF 72   | with               | 0.8                | 1.2                 | 1.3            | -              |
| MAN-RF 74   | with               | 0.8                | 1.2                 | 1.3            | -              |
| MAN-RF 74 V | with               | 0.9                | 1.3                 | 1.4            | -              |

| NG 160      |         |     |     |     |     |
|-------------|---------|-----|-----|-----|-----|
| MAN-RG 22   | without | 1.0 | 1.3 | 1.4 | 1.5 |
| MAN-RG 24   | without | 1.0 | 1.3 | 1.4 | 1.5 |
| MAN-RG 24 V | without | 1.1 | 1.4 | 1.5 | 1.6 |
| MAN-RG 32   | without | 1.1 | 1.5 | 1.6 | 1.7 |
| MAN-RG 34   | without | 1.2 | 1.5 | 1.7 | 1.8 |
| MAN-RG 34 K | without | 1.3 | 1.6 | 1.7 | 1.8 |
| MAN-RG 34 V | without | 1.3 | 1.6 | 1.7 | 1.8 |
| MAN-RG 62   | with    | 1.9 | 2.9 | 3.4 | 3.6 |
| MAN-RG 64   | with    | 1.9 | 2.9 | 3.4 | 3.6 |
| MAN-RG 64 K | with    | 2.0 | 3.0 | 3.5 | 3.7 |
| MAN-RG 64 V | with    | 2.0 | 3.0 | 3.5 | 3.7 |
| MAN-RG 72   | with    | 1.8 | 2.8 | 3.2 | -   |
| MAN-RG 74   | with    | 1.8 | 2.8 | 3.2 | -   |
| MAN-RG 74 V | with    | 1.9 | 2.9 | 3.3 | -   |





**Magnetic spring contacts/slow-action contacts**

| Limit monitor with 1 contact                                      |                                       |                                   |
|---|---------------------------------------|-----------------------------------|
| Switching function<br>(when the limit value is exceeded)          | Order code<br>Magnetic spring contact | Order code<br>Slow action contact |
| Contact closes  | ..M1                                  | ..S1                              |
| Contact opens   | ..M2                                  | ..S2                              |
| Contact switches over,<br>that is, contact opens, contacts closes | ..M3                                  | ..S3                              |

| Limit monitor with 2 contacts          |       |       |
|--|-------|-------|
| First and second contact closes        | ..M11 | ..S11 |
| 1. Contact closes<br>2. Contact opens  | ..M12 | ..S12 |
| 1. Contact opens<br>2. Contact closes  | ..M21 | ..S21 |
| First and second contact opens         | ..M22 | ..S22 |
| First and second contact switches over | ..M33 | ..S33 |

| Limit monitor with 3 contacts                                 |       |       |
|---|-------|-------|
| 3 contacts close  | ..M3A | ..S3A |
| 3 contacts open   | ..M3Z | ..S3Z |
| 3 contacts, switching function<br>upon customer specification | ..M3G | ..S3G |

| Limit monitor with 4 contacts                                 |       |       |
|---|-------|-------|
| 4 contacts close  | ..M4A | ..S4A |
| 4 contact open  | ..M4Z | ..S4Z |
| 4 conatcts, switching function<br>upon customer specification | ..M4G | ..S4G |



**Inductive contacts/pneumatic contacts**

| <b>Limit monitor with 1 contact</b>  |   |                                     |                                     |
|--|---|-------------------------------------|-------------------------------------|
| <b>If the pressure gauge moves clockwise it will move the control lug when the set limit is exceeded</b> | <b>Control action</b>                         | <b>Order code Inductive contact</b> | <b>Order code Pneumatic contact</b> |
| out of the control head  | Control current/air current circuit is closed | <b>..I1</b>                         | <b>..P1</b>                         |
| into the control head  | Control current/air current circuit is opened | <b>..I2</b>                         | <b>..P2</b>                         |

| <b>Limit monitor with 2 contacts</b>   |   |              |              |
|--|---|--------------|--------------|
| of the 1. and 2. contact from the control head                                   | Control current/air current circuits are closed   | <b>..I11</b> | <b>..P11</b> |
| of the 1. contact from the control head<br>of the 2. contact in the control head | 1. Control current/air current circuit closes<br>2. Control current/air current circuit opens | <b>..I12</b> | <b>..P12</b> |
| of the 1. contact from the control head<br>of the 2. contact in the control head | 1. Control current/air current circuit opens<br>2. Control current/air current circuit closes | <b>..I21</b> | <b>..P21</b> |
| of the 1. and 2. contact from the control head                                   | Control current/air current circuits are opened   | <b>..I22</b> | <b>..P22</b> |



Pin assignment

| Contact                              | Cable box (standard)               | DIN 43651 (round Hirschmann)     |
|--------------------------------------|------------------------------------|----------------------------------|
| <b>Magnetic-/slow action contact</b> | <b>K = contact / R = conductor</b> | <b>plus cable connection</b>     |
| <b>1 Conductor</b>                   | <b>E = earth / mass</b>            |                                  |
| M/S 1                                | K=1 R=2 E=6                        | K=1 R=2 E=E                      |
| M/S 2                                |                                    |                                  |
| M/S 3                                | K11=1 K13=2 R1=3 E=6               | K11=1 K13=2 R1=3 E=6             |
| M/S 11                               | K1=1 K2=2 R=3 E=6                  | K1=1 K2=2 R=3 E=E                |
| M/S 12                               |                                    |                                  |
| M/S 21                               |                                    |                                  |
| M/S 22                               |                                    |                                  |
| M/S 33                               | K11=1 K13=2 K21=3 K23=4 R2=5 E=6   | K11=1 K13=2 K21=3 K23=4 R2=5 E=E |
| M/S 111                              | K1=1 K2=2 K3=3 R=4 E=6             | K1=1 K2=2 K3=3 R=4 E=E           |
| M/S 112                              |                                    |                                  |
| M/S 121                              |                                    |                                  |
| M/S 122                              |                                    |                                  |
| M/S 211                              |                                    |                                  |
| M/S 212                              |                                    |                                  |
| M/S 221                              |                                    |                                  |
| M/S 222                              |                                    |                                  |
| M/S 1111                             | K1=1 K2=2 K3=3 K4=4 R=5 E=6        | K1=1 K2=2 K3=3 K4=4 R=5 E=E      |
| M/S 1112                             |                                    |                                  |
| M/S 1121                             |                                    |                                  |
| M/S 1211                             |                                    |                                  |
| M/S 1122                             |                                    |                                  |
| M/S 1221                             |                                    |                                  |
| M/S 1222                             |                                    |                                  |
| M/S 2111                             |                                    |                                  |
| M/S 2112                             |                                    |                                  |
| M/S 2121                             |                                    |                                  |
| M/S 2211                             |                                    |                                  |
| M/S 2122                             |                                    |                                  |
| M/S 2212                             |                                    |                                  |
| M/S 2221                             |                                    |                                  |
| M/S 2222                             |                                    |                                  |

| Contact                              | Cable box (standard)                  | DIN 43651 (round Hirschmann)          |
|--------------------------------------|---------------------------------------|---------------------------------------|
| <b>Magnetic-/slow action contact</b> | <b>K = contact / R = conductor</b>    | <b>plus cable connection</b>          |
| <b>Separated return conductor</b>    | <b>E = earth / mass</b>               |                                       |
| M/S 11                               | K1=1 R1=3 K2=2 R2=4 E=6               | K1=1 R1=3 K2=2 R2=4 E=E               |
| M/S 12                               |                                       |                                       |
| M/S 21                               |                                       |                                       |
| M/S 22                               |                                       |                                       |
| M/S 33                               | K11=1 K13=2 R1=3 K21=4 K23=5 R2=6 E=E | K11=1 K13=2 R1=3 K21=4 K23=5 R2=6 E=E |
| M/S 111                              | K1=1 R1=2 K2=3 R2=4 K3=5 R3=6 E=E     | K1=1 R1=2 K2=3 R2=4 K3=5 R3=6 E=E     |
| M/S 112                              |                                       |                                       |
| M/S 121                              |                                       |                                       |
| M/S 122                              |                                       |                                       |
| M/S 211                              |                                       |                                       |
| M/S 212                              |                                       |                                       |
| M/S 221                              |                                       |                                       |
| M/S 222                              |                                       |                                       |



**Pin assignment**

| Contact                  | Cable box (standard)                       | DIN 43651 (round Hirschmann))             |
|--------------------------|--|---|
| <b>Inductive contact</b> | <b>K = contact / R = conductor</b>         | <b>plus cable connection</b>              |
|                          | <b>E = earth / mass</b>                    |   |
| I 1                      | -K=1 +K1=2 E=6                             | -K=1 +K2=2 E=E                            |
| I 2                      |  |   |
| I 11                     | -K1=1 +K1=3 -K2=2 +K2=4 E=E                | -K=1 +K1=3 -K2=2 +K2=4 E=E                |
| I 12                     |  |   |
| I 21                     |  |   |
| I 22                     |  |   |
| I 111                    |  |   |
| I 112                    |  |   |
| I 121                    | -K1=1 +K1=2 -K2=3 +K2=4 -K3=5 +K3=6<br>E=E | -K=1 +K1=2 -K2=3 +K2=4 -K3=5 +K3=6<br>E=E |
| I 122                    |  |   |
| I 211                    |  |   |
| I 212                    |  |   |
| I 221                    |  |   |
| I 222                    |  |   |

| Contact                               | DIN 43650   | M12; 5 pole            |
|---------------------------------------|---|------------------------|
| <b>Magnetic-/ slow action contact</b> | <b>(Cube plug)</b>                                    |                        |
| <b>1 Conductor</b>                    | <b>K = contact / R = conductor / E = earth / mass</b> |                        |
| M/S 1                                 | K=1 R=2 E=E   | K=1 R=2 E=5            |
| M/S 2                                 |   |                        |
| M/S 3                                 | K11=1 K13=2 R1=3 E=E                                  | K11=1 K13=2 R1=3 E=5   |
| M/S 11                                | K1=1 K2=2 R=3 E=E                                     | K1=1 K2=2 R=3 E=5      |
| M/S 12                                |   |                        |
| M/S 21                                |   |                        |
| M/S 22                                |   |                        |
| M/S 33                                | not possible  | not possible           |
| M/S 111                               | not possible  | K1=1 K2=2 K3=3 R=4 E=5 |
| M/S 112                               |   |                        |
| M/S 121                               |   |                        |
| M/S 122                               |   |                        |
| M/S 211                               |   |                        |
| M/S 212                               |   |                        |
| M/S 221                               |   |                        |
| M/S 222                               |   |                        |

| Contact                               | DIN 43650   | M12; 5 pole                 |
|---------------------------------------|---|-----------------------------|
| <b>Magnetic-/ slow action contact</b> | <b>(Cube plug)</b>                                    |                             |
| <b>Separated return conductor</b>     | <b>K = contact / R = conductor / E = earth / mass</b> |                             |
| M/S 11                                | not possible  | K1=1 R1=3 K2=2 R2=4 E=5     |
| M/S 12                                |   |                             |
| M/S 21                                |   |                             |
| M/S 22                                |   |                             |
| <b>Inductive contact</b>              |   |                             |
| I 1                                   | -K1=1 +K1=2 E=E                                       | -K1=1 +K1=2 E=5             |
| I 2                                   |   |                             |
| I 11                                  | not possible  | -K1=1 +K1=3 -K2=2 +K2=4 E=5 |
| I 12                                  |   |                             |
| I 21                                  |   |                             |
| I 22                                  |   |                             |