



Magnetic-inductive Flow Meter Insertion Version



measuring
•
monitoring
•
analysing

PITe + U-PACE



 **IO-Link**



KofiCom Interface set

- For measuring conductive liquids
- Maintenance-free
- Low pressure loss
- Bidirectional measurement
- Measuring range: up to 10 m/s
- Accuracy: $\pm 1,5\%$ of reading
 $\pm 2,5\%$ of full scale
- p_{\max} : PN 16
- t_{\max} : $-20 \dots +100 \text{ } ^\circ\text{C}$
- Connection: welding stub and M52 x2 union nut for DN 80 ... 400
- Material: stainless steel / PTFE, Hastelloy® electrodes
- Outputs: 2 x freely configurable



KOBOLD companies worldwide:

AUSTRALIA, AUSTRIA, BELGIUM, BULGARIA, CANADA, CHINA, CZECHIA, FRANCE, GERMANY, GREAT BRITAIN, HUNGARY, INDIA, INDONESIA, ITALY, MALAYSIA, MEXICO, NETHERLANDS, PERU, POLAND, REPUBLIC OF KOREA, SPAIN, SWITZERLAND, THAILAND, TUNISIA, TURKEY, USA, VIETNAM

KOBOLD Messring GmbH
Nordring 22-24
D-65719 Hofheim/Ts.
Head Office:
+49(0)6192 299-0
+49(0)6192 23398
info.de@kobold.com
www.kobold.com

Description

An electrically conductive medium flowing through an orientated magnetic field in accordance to Faraday's law of induction will induce a voltage proportional to the mean flow velocity rate and hence the volumetric flow.

A magnetic inductive flow meter consists of a tube through which a conductive liquid flows, a magnetic field coil and two electrodes. The induced voltage is processed by an evaluating electronics.

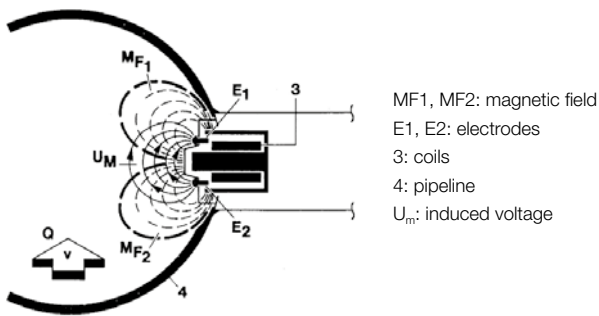

The units include a universal U-PACE electronics (Universal Precision and Control Electronics) which features two outputs arbitrarily configurable by the customer.

The U-PACE electronics offers various diagnostic functions and the following features:

- Flow measurement
- Monitoring, dosing and transmitter function
- Dosing function with external control input
- Coloured, multi-parameter configurable TFT-display, rotatable in 90° steps
- Bidirectional measuring
- Intuitive setup menu via 4 optical touch keys
- 2 configurable outputs (pulse-/frequency-/alarm- and analogue output)
- Adaptation to internal pipe diameter by the customer
- Grand and resettable totaliser

Application

The magnetic-inductive flow sensor PITe is used to measure the volume flow of liquids, slurries, pastes and other electrically conductive media with almost no pressure drop. Pressure, temperature, density and viscosity do not affect the volume measurements. Solid particles and small gas bubbles should be avoided.

The sensor PITe has the following significant characteristics:

- simple design
- maintenance-free
- very compact design
- almost no pressure drop

Technical Details

Measuring ranges: see Measuring range table

Measured media: conductive liquids

Minimum conductivity: $\geq 20 \mu\text{S/cm}$

Sensor

Armature: stainless steel 1.4404, 316L, PTFE

Electrodes: Hastelloy® (others on request)

Nominal diameters: DN80 ... DN400, 3" ... 16" ANSI

Process connection: welding stub $\varnothing 40$ mm stainless steel 1.4404, 316L
with M5x2 union nut stainless steel 1.4404/316L
(other connections on request)

Nominal pressure: PN16 (16 bar/90 °C; 14 bar/100 °C)

Process temperature: -20 °C ... +100 °C, stainless steel, PTFE

Ambient temperature: -20 °C ... +60 °C

Conductivity: $\geq 20 \mu\text{S/cm}$

Straight inlet- outlet: 10xD inlet, 5xD outlet

Measuring range: 1 m/s ... 10 m/s

Measurement

deviation: at ($Q \geq 30\%$ of full scale): $\pm 1.5\%$ of reading

at ($Q \leq 30\%$ of full scale): $\pm 1.5\%$ of reading $\pm 2.5\%$ of full scale (under reference conditions*)

Repeatability: $\pm 0.75\%$ (under reference conditions)

Protection: IP 65 sensor, PVC cable
IP 67 transmitter U-PACE

Transmitter U-PACE

Flow response time t_{90} :

(alarm/pulse/frequency output): < 100 ms

(analog output): < 1 s

Operation: 4 optical buttons, can be operated with gloves**

Housing: stainless steel 1.4404
display window: PMMA

Electrical data

Supply voltage: 19 - 30 V_{DC}, internal power consumption max. 200 mA

Display: TFT display, 128x128 pixels, 1.4" display orientation in 90° steps adjustable

Display repetition rate: 0.5 ... 10 s, adjustable

Pulse output: Push-Pull, freely scalable, configurable for partial and accumulated totaliser

* Under reference conditions: media temperature: 15 °C ... 30 °C, 1 cSt, 500 $\mu\text{S/cm}$, 1 bar
ambience temperature: 15 °C ... 30 °C

** Limited functionality with black rubber gloves



Technical Details (continued)

Frequency output	Push-Pull, freely scalable, 2 kHz @ overflow f_{min} @ FS = 50 Hz f_{max} @ FS = 1000 Hz	Dosing function:	Dosing output OUT2: Push-Pull, High active Control input OUT1: START/STOP 0.5 s < t_{high} < 4 s RESET t_{high} > 5 s
Alarm output:	NPN, PNP, Push-Pull, configurable max. 30 V _{DC} , max. 200 mA short-circuit proof	Electrical connection:	plug M12x1, 4-pin
Analogue output:	active, 3 wire, 0(4)-20 mA, max. load 500 Ω or 0(2)-10 V _{DC} , (R _i = 500 Ω) (factory calibrated with R _L = 1 MΩ)		
Control input:	active signal U _{high} max. 30 V _{DC} 0 < Low < 10 V _{DC} 15 V _{DC} < High < Vs		

Configuration of outputs

Output 1 (OUT1, PIN 4)	Output 2 (OUT2, PIN 2)
Analogue output 4-20 mA	Analogue output 4-20 mA
Analogue output 0-20 mA	Analogue output 0-20 mA
Analogue output 2-10 V	Analogue output 2-10 V
Analogue output 0-10 V	Analogue output 0-10 V
Switching output NPN/PNP/PP	Switching output NPN/PNP/PP
Pulse output PP	Pulse output PP
Frequency output PP	Frequency output PP
Communication mode KofCom	
Communication mode IO-Link	
Control input	
Control input dosing function	Dosing output

IO-Link specification

Manufacturer ID:	1105 (decimal), 0 x 0451 (hex)
Manufacturer name:	Kobold Messring GmbH
IO-Link specification:	V1.1
Bitrate:	COM3
Minimal cycle time:	1,1 ms
SIO-Mode:	yes (OUT1 in configuration IO-Link)
Block parameterisation:	yes
Operational readiness:	10 s
Max. cable length:	20 m

Electrical Connection

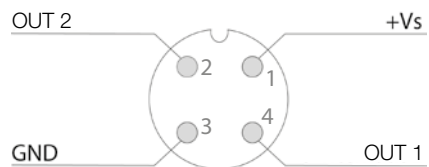



Measuring range table

Recommended flow rates according to pipe diameter

Nominal diameter*		Min/Max flow (1 - 10 m/s)	
[mm]	[inch]	Q _{min} (1 m/s)	Q _{max} (10 m/s)
DN80		19.2 m ³ /h	192 m ³ /h
	3"	76 GPM	756 GPM
DN100		32.4 m ³ /h	324 m ³ /h
	4"	131 GPM	1302 GPM
DN125		49.0 m ³ /h	490 m ³ /h
	5"	205 GPM	2046 GPM
DN150		71.8 m ³ /h	718 m ³ /h
	6"	296 GPM	2954 GPM
DN200		121.5 m ³ /h	1215 m ³ /h
	8"	512 GPM	5116 GPM
DN250		191.7 m ³ /h	1917 m ³ /h
	10"	807 GPM	8064 GPM
DN300		271.2 m ³ /h	2712 m ³ /h
	12"	1160 GPM	11565 GPM
DN350		326.1 m ³ /h	3261 m ³ /h
	14"	1410 GPM	14100 GPM
DN400		430.9 m ³ /h	4309 m ³ /h
	16"	1870 GPM	18678 GPM

*Designed for wall thickness according to DIN EN 10253-2 or ASME B 36.10M series 40S (STD)

PITe-Converter/Rescaler for Custom Pipe Inner Flow Meter

Tool	Required Hardware	Download Link
Excel calculation	none	https://www.kobold.com/qr/PIT 
Windows PC software	KOFICOM-IFMU	



Order Details (example: PITE-SHWD80P050)

Model	Material	Process connection
PITE- = Magn. inductive, insertion type	SH = Armature: stainless steel (1.4571/1.4404), PTFE Electrodes: Hastelloy® C-4	W = Weld-on adaptor incl. union nut PN16

For nominal size**	Inner diameter			ME (approx. 10 m/s)	U-PACE Electronics**	Special options
	[mm]	[in]	[converted to mm]			
D80 = DN80	82.5			192 m³/h	P05 = remote version, 5 m PVC cable P10 = remote version, 10 m PVC cable P15 = remote version, 15 m PVC cable P20 = remote version, 20 m PVC cable	0 = without
A80 = 3"		3.068	77.93	756 GPM		
D1H = DN100	107.1			324 m³/h		
A1H = 4"		4.026	102.26	1302 GPM		
D1Z = DN125	131.7			490 m³/h		
A1Z = 5"		5.047	128.19	2046 GPM		
D1F = DN150	159.3			718 m³/h		
A1F = 6"		6.065	154.05	2954 GPM		
D2H = DN200	206.5			1215 m³/h		
A2H = 8"		7.981	202.72	5116 GPM		
D2F = DN250	260.4			1917 m³/h		
A2F = 10"		10.02	254.51	8064 GPM		
D3H = DN300	309.7			2712 m³/h		
A3H = 12"		12	304.80	11 565 GPM		
D3F = DN350	339.6			3261 m³/h		
A3F = 14"		13.25	336.55	14 100 GPM		
D4H = DN400	390.4			4309 m³/h		
A4H = 16"		15.25	387.35	18 678 GPM		
DXX customer specific	specify in clear text			see Flow Equation		
AXX customer specific	specify in clear text			see Flow Equation		

*(designed for wall thickness according to DIN EN 10253-2 or ASME B 36.10M series 40S (STD))

**Mounting bracket incl. accessories for wall bracket is included in the scope of delivery

Flow Equation

Q (m³/h) = 0.02827433 x D² („D“ is inner pipe dia in mm) for Flow „Q“ in m³/h

Q (GPM) = 80.3147 x D² („D“ is inner pipe dia in inches) for Flow „Q“ in USGPM

Order details Certificates

Certificate	Code
Certificate of compliance 2.1	DOK-F3-01
Works certificate 2.2	DOK-F3-02
Inspection certificate 3.1	DOK-HMT0B
Inspection certificate 3.2	DOK-HMT0C

Order Details Spare Part/Accessories

Model	Description	Image
KOFICOM-IFMU	PC-Interface Set (necessary for the use of „Software Mediator Tools“) comprising: <ul style="list-style-type: none"> • KofiCom Interface • USB cable (length: 1 m) for connection PC <-> Kofi-Com Interface • M12 cable with plug + socket (length: 1 m each) for connecting of device 	
ERS-ZOK-023618	Stainless steel wall mounting kit for remote version (2 brackets, with nuts/washers)	



Example for setting all outputs via customisation by the USER unit

Order a device parameterized to your pipe size.

If this is not possible, order a device with a larger inner pipe diameter than your pipe.

- You must adjust the cutoff in the U-PACE to your new start of the measuring range
- You must adapt your analog outputs for voltage and current in the U-PACE
- You must adapt your frequency output in the U-PACE
- The overflow function no longer works correctly:
 - The display colour changes at the wrong flow value - see sheet "Read me"
 - IO-Link outputs the error message "Overflow" at the wrong flow value - see sheet "Read me"

Example 1: Your pipe inner diameter is larger than the inner diameter stored in the device	Example 2: Your pipe inner diameter is smaller than the inner diameter saved in the device																																				
<p>The following values have been saved in your device at the factory: Start of measuring range: 1 m/s End of measuring range: 10 m/s</p> <p>Due to your larger inner pipe diameter, more medium will flow through your pipe at 10 m/s, so your maximum flow rate at 10 m/s will be higher than what is saved in the device. Likewise, at 1 m/s more medium will flow through your pipe, your minimum flow will also be higher than saved in the device.</p>	<p>The following values have been saved in your device at the factory: Start of measuring range: 1 m/s End of measuring range: 10 m/s</p> <p>Due to your smaller inner pipe diameter, less medium will flow through your pipe at 10 m/s, so your maximum flow rate will be lower than what is saved in the device. Likewise, at 1 m/s less medium will flow through your pipe, your minimum flow will also be lower than saved in the device.</p>																																				
<table border="1"> <thead> <tr> <th>Example values:</th> <th>Device code</th> <th>Inner diameter</th> <th>Minimal flow 1 m/s</th> <th>Maximum flow 10m/s</th> <th>Cutoff U-PACE</th> </tr> </thead> <tbody> <tr> <td>You have ordered:</td> <td>A1H</td> <td>4.026 inch</td> <td>12.1 galUS/h</td> <td>121 galUS/h</td> <td>12.1 galUS/h</td> </tr> <tr> <td>Your pipe has:</td> <td>Axx</td> <td>4.2 inch</td> <td>13.2 galUS/h</td> <td>132 galUS/h</td> <td>13.2 galUS/h</td> </tr> </tbody> </table>	Example values:	Device code	Inner diameter	Minimal flow 1 m/s	Maximum flow 10m/s	Cutoff U-PACE	You have ordered:	A1H	4.026 inch	12.1 galUS/h	121 galUS/h	12.1 galUS/h	Your pipe has:	Axx	4.2 inch	13.2 galUS/h	132 galUS/h	13.2 galUS/h	<table border="1"> <thead> <tr> <th>Example values:</th> <th>Device code</th> <th>Inner diameter</th> <th>Minimal flow 1 m/s</th> <th>Maximum flow 10m/s</th> <th>Cutoff U-PACE</th> </tr> </thead> <tbody> <tr> <td>You have ordered:</td> <td>A1H</td> <td>4.026 inch</td> <td>12.1 galUS/h</td> <td>121 galUS/h</td> <td>12.1 galUS/h</td> </tr> <tr> <td>Your pipe has:</td> <td>Axx</td> <td>3.9 inch</td> <td>11.4 galUS/h</td> <td>114 galUS/h</td> <td>11.4 galUS/h</td> </tr> </tbody> </table>	Example values:	Device code	Inner diameter	Minimal flow 1 m/s	Maximum flow 10m/s	Cutoff U-PACE	You have ordered:	A1H	4.026 inch	12.1 galUS/h	121 galUS/h	12.1 galUS/h	Your pipe has:	Axx	3.9 inch	11.4 galUS/h	114 galUS/h	11.4 galUS/h
Example values:	Device code	Inner diameter	Minimal flow 1 m/s	Maximum flow 10m/s	Cutoff U-PACE																																
You have ordered:	A1H	4.026 inch	12.1 galUS/h	121 galUS/h	12.1 galUS/h																																
Your pipe has:	Axx	4.2 inch	13.2 galUS/h	132 galUS/h	13.2 galUS/h																																
Example values:	Device code	Inner diameter	Minimal flow 1 m/s	Maximum flow 10m/s	Cutoff U-PACE																																
You have ordered:	A1H	4.026 inch	12.1 galUS/h	121 galUS/h	12.1 galUS/h																																
Your pipe has:	Axx	3.9 inch	11.4 galUS/h	114 galUS/h	11.4 galUS/h																																
<p>Your device is preset to the following outputs:</p> <table border="1"> <thead> <tr> <th>Output:</th> <th>Value [galUS/h]</th> </tr> </thead> <tbody> <tr><td>0 mA</td><td>0</td></tr> <tr><td>4 mA</td><td>0</td></tr> <tr><td>20 mA</td><td>121</td></tr> <tr><td>0 V</td><td>0</td></tr> <tr><td>2 V</td><td>0</td></tr> <tr><td>10 V</td><td>121</td></tr> <tr><td>0 Hz</td><td>0</td></tr> <tr><td>max. Hz</td><td>121</td></tr> </tbody> </table>	Output:	Value [galUS/h]	0 mA	0	4 mA	0	20 mA	121	0 V	0	2 V	0	10 V	121	0 Hz	0	max. Hz	121	<p>Your device is preset to the following outputs:</p> <table border="1"> <thead> <tr> <th>Output:</th> <th>Value [galUS/h]</th> </tr> </thead> <tbody> <tr><td>0 mA</td><td>0</td></tr> <tr><td>4 mA</td><td>0</td></tr> <tr><td>20 mA</td><td>121</td></tr> <tr><td>0 V</td><td>0</td></tr> <tr><td>2 V</td><td>0</td></tr> <tr><td>10 V</td><td>121</td></tr> <tr><td>0 Hz</td><td>0</td></tr> <tr><td>max. Hz</td><td>121</td></tr> </tbody> </table>	Output:	Value [galUS/h]	0 mA	0	4 mA	0	20 mA	121	0 V	0	2 V	0	10 V	121	0 Hz	0	max. Hz	121
Output:	Value [galUS/h]																																				
0 mA	0																																				
4 mA	0																																				
20 mA	121																																				
0 V	0																																				
2 V	0																																				
10 V	121																																				
0 Hz	0																																				
max. Hz	121																																				
Output:	Value [galUS/h]																																				
0 mA	0																																				
4 mA	0																																				
20 mA	121																																				
0 V	0																																				
2 V	0																																				
10 V	121																																				
0 Hz	0																																				
max. Hz	121																																				
<p>You now want to have 20mA at 10m/s on Output 1: This setting is not possible.</p> <p>You do not want to see any values below the start of your measuring range: Cutoff is to be increased from 12.1 galUS/h to 13.2 galUS/h</p> <p>You have connected your device via IO-Link and want to use the overflow status: Your device returns the status "Overflow" at a flow rate of 10 % above the end of the measuring range Overflow status is set at: $121 \text{ galUS/h} \cdot 1.10 = 133.1 \text{ galUS/h}$ Overflow status would be correct at: $132 \text{ galUS/h} \cdot 1.10 = 145.2 \text{ galUS/h}$ It is not possible to set this value via the U-PACE electronics. Your overflow status is not delivered correctly to your controller.</p>	<p>You now want to have 20mA at 10m/s on Output 1: Output 1 must now be adjusted so that the 20mA point is at 114 galUS/h instead of 121 galUS/h</p> <p>You do not want to see any values below the start of your measuring range: Cutoff is to be decreased from 12.1 galUS/h to 11.4 galUS/h</p> <p>You have connected your device via IO-Link and want to use the overflow status: Your device returns the status "Overflow" at a flow rate of 10 % above the end of the measuring range Overflow status is set at: $121 \text{ galUS/h} \cdot 1.10 = 133.1 \text{ galUS/h}$ Overflow status would be correct at: $114 \text{ galUS/h} \cdot 1.10 = 125.4 \text{ galUS/h}$ It is not possible to set this value via the U-PACE electronics. Your overflow status is not delivered correctly to your controller.</p>																																				

Installation conditions

Interference points (eg. Shut-off and control valves) shall be arranged in flow direction behind the sensor. If this is not possible, calming sections should be provided so that no vortex can extend into the measuring track of the sensor. The installation position in the pipeline should be chosen so that the sensor is always completely immersed in the fluid. Sewer pipes and non-return valves ensure this requirement.

Immersion depth

The weld spigots must be installed so that the sensor tip, regardless of the pipeline nominal diameter, 40 mm projects in the pipeline.

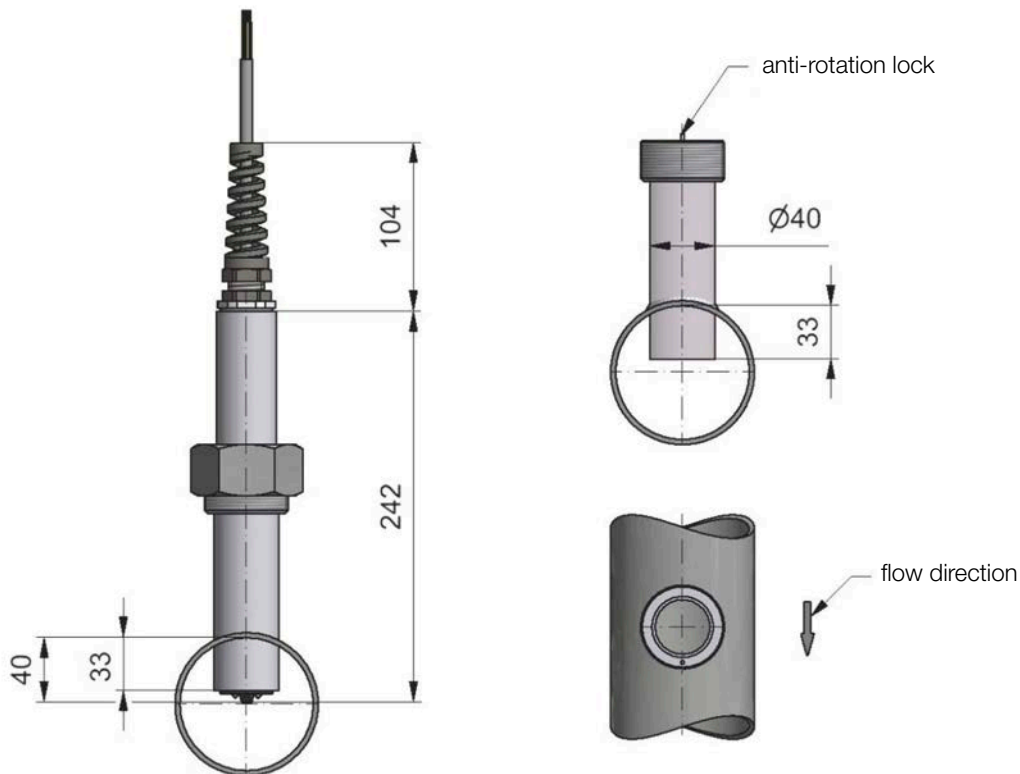

Preferred mounting position

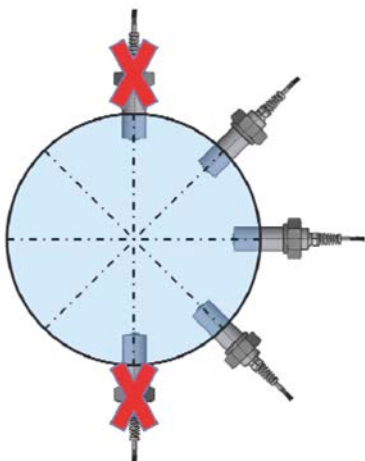

To avoid possible sources of error, the ideal angle of installation lies between 45° and 135°.

Top mounted (at 0°): gas bubbles may gather.

Bottom mounted (at 180°): deposits may arise.

Dimensions [mm]

Transmitter U-PACE

Without wall mounting brackets

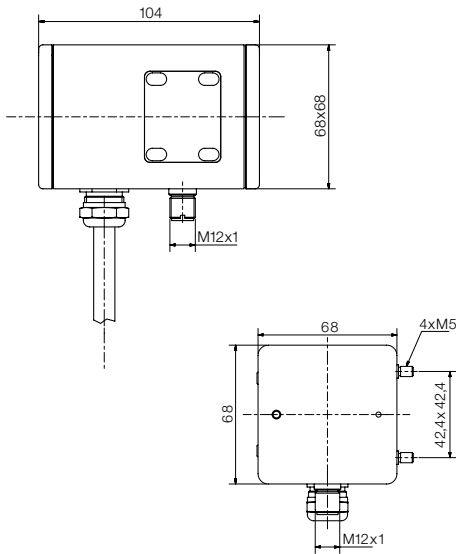

With wall mounting brackets

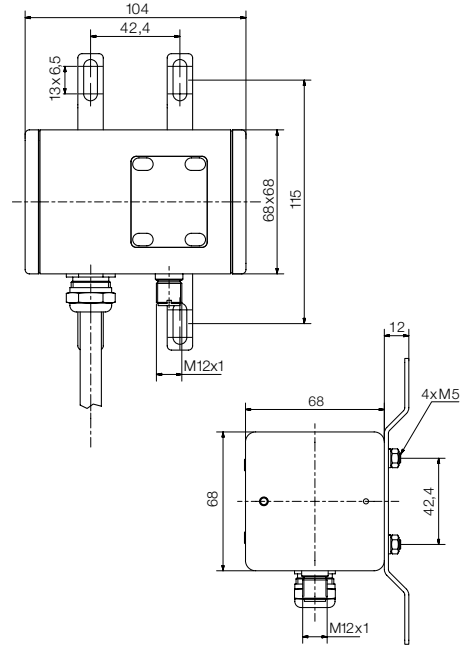

Sensor PITe

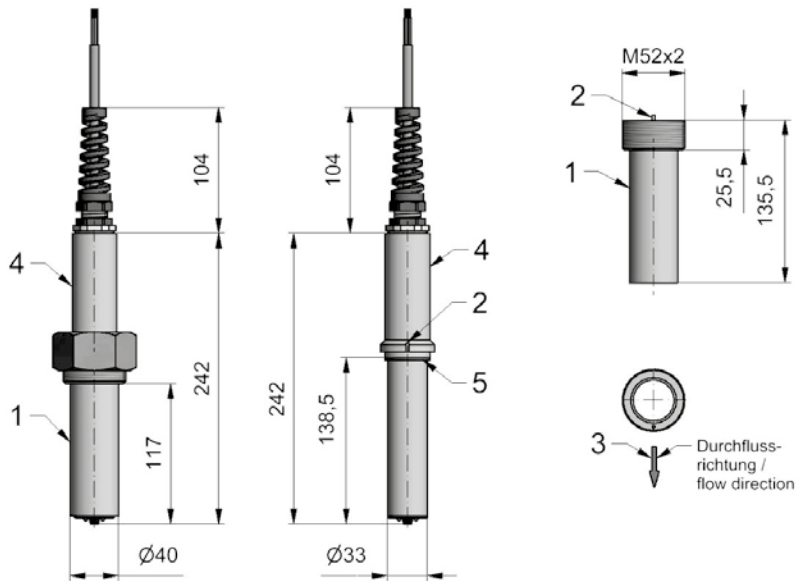

- 1: Welding socket
- 2: Anti-rotation lock
- 3: Flow direction
- 4: Armature
- 5: Gasket



Measuring Mode, Display Layout »Single« configurable

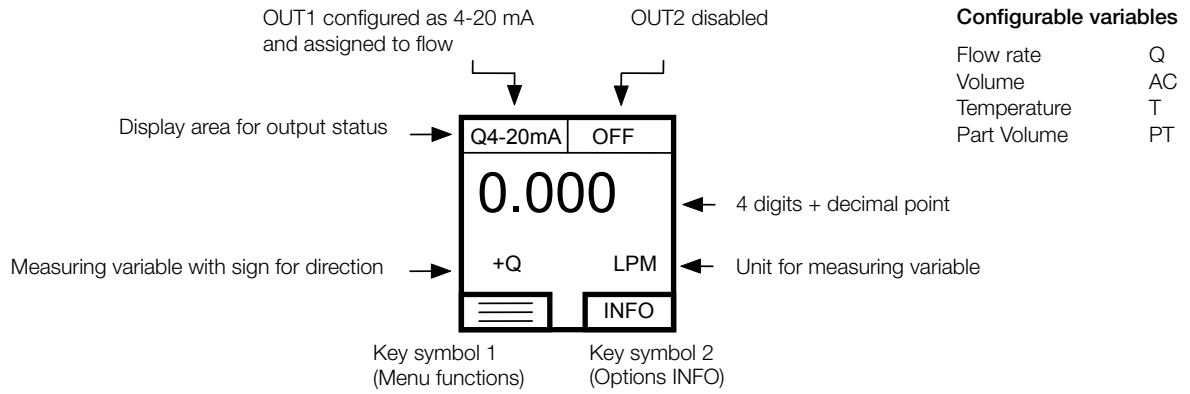

* M e a s u r e d V a l u e