



Electromagnetic Flow Meter compact for conductive liquids



measuring
•
monitoring
•
analysing

MIK



MIK with frequency-, switching-, analogue output

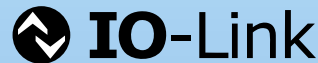

MIK with digital plug on display

- Range from liquids, acids and caustic solutions:
0.01-0.5 ... 35-700 l/min
- Accuracy: $\pm 2.0\%$ of full scale
- p_{max} : 10 bar; t_{max} : 80 °C
- Connection: G 1/2 ... G 2 3/4 male, diverse accessories
- Material:
normal liquids: PPS, stainless steel
aggressive liquids: PVDF, Hastelloy® or Tantalum
- Advantage:
 - no moving parts in the measuring tube
 - low pressure loss
 - any mounting position
 - short reaction time – replacement for calorimetric flow switch
 - high quality for lowest price



MIK with U-PACE electronics



Display rotatable in 90° steps



GS

KOBOLD companies worldwide:

AUSTRALIA, AUSTRIA, BELGIUM, BULGARIA, CANADA, CHINA, CZECHIA, FRANCE, GERMANY, GREAT BRITAIN, HUNGARY, INDIA, INDONESIA, ITALY, MALAYSIA, MEXICO, NETHERLANDS, PERU, POLAND, REPUBLIC OF KOREA, SPAIN, SWITZERLAND, THAILAND, TUNISIA, TURKEY, USA, VIETNAM

KOBOLD Messring GmbH
Nordring 22-24
D-65719 Hofheim/Ts.
Head Office:
+49(0)6192 299-0
+49(0)6192 23398
info.de@kobold.com
www.kobold.com



Description

The new KOBOLD flow meter Type MIK is used for measuring and monitoring smaller and medium-sized flow of conductivity liquids in pipes.

The device operates according to the electromagnetic measurement principle. According to Faraday's Law of magnetic induction a voltage is induced in a conductor moving through a magnetic field. The electrically conductive measuring agent acts as the moved conductor. The voltage induced in the measuring agent is proportional to the flow velocity and is therefore a value for the volumetric flow. The flowing media must have a minimum conductivity. The induced voltage is picked up by two sensing electrodes which are in contact with the measuring agent and sent to the measuring amplifier. The flow rate will be calculated based on the cross sectional area of the pipe.

The measurement is not depending on the process liquid and its material properties such as density, viscosity and temperature. The devices can be equipped with a switching output, a frequency output or an analogue output. In addition, a universal U-PACE electronics (Universal Precision and Control Electronics, order code C3T0) is available and features two outputs arbitrarily configurable by the customer.

The compact electronics offers various diagnostic functions and the following features:

- Flow- and temperature measurement
- Monitoring, dosing and transmitter function
- Dosing function with external control input
- Coloured, multi-parameter configurable TFT-display, rotatable in 90° steps
- Bidirectional measuring
- Intuitive setup menu via 4 optical touch keys
- 2 configurable outputs (pulse-/frequency-/alarm- and analogue output)
- Grand and resettable totaliser
- IO link function
- CSA certification of U-PACE electronics for Ordinary Locations (Ordloc)
- International IECCE Certification acc. to CB-Scheme with U-PACE

Media

- Electric conductivity liquids
- Acids and caustic solutions
- Cooling and waste water
- Ground water, raw water
- Aggressive or salty solution
- Unsuitable for oil (missing conductivity)

Areas of Application

Flow monitoring, flow measuring, dosing and counting for

- Machine building
- Chemical Industry
- Paper Industry
- Automobile Industry
- Cement Industry
- Laboratory

Technical Details

Range: see table
 Accuracy: ±2.0 % of full scale
 Repeat accuracy: ±1.0 % of full scale
 Measurement process: electromagnetic
 Electrical conductivity: min. 30 µS/cm (at MIK-...08 and 10: min. 200 µS/cm)
 Mounting position: in all directions, flow in direction of the arrow
 In-/Outlet: 3 x DN / 2 x DN
 Media temperature: -20... +80 °C (max. +60 °C with PVC-connection set)
 Ambient temperature: -10... +60 °C
 Max. pressure: 10 bar
 Max. pressure loss: max. 250 mbar at full scale
 Max. medium viscosity: 20 cSt ≤ G1;
 70 cSt ≥ G1½

Wetted Parts

Sensor housing: PPS or PVDF, fibreglass-reinforced
 Connection set: PVC-gluе connection or hose connection, weld-on ends stainless steel 1.4404
 Electrodes: stainless steel 1.4404, Hastelloy® C4 or Tantalum
 Seal: NBR, FPM or FFKM
 Response time t₉₀: approximately 1 s (at flow changes >10% FS)
 Protection: IP65

Temperature measurement (C3T0)

Sensor: digital
 Accuracy: ≤±2 °C (flow >0.2 m/s)
 Measuring range: temperature range of medium
 Response time temperature t₉₀ (signal output): <20 s

Connection/Ranges

Connection	Inside diameter	Flow velocity at full scale	Range
G ½ male	5 mm	approx. 0.45 m/s	10...500 ml/min
		approx. 0.9 m/s	0.05... 1.0 l/min
		approx. 2.7 m/s	0.16...3.2 l/min
G ¾ male	10 mm	approx. 2.2 m/s	0.5... 10.0 l/min
		approx. 3.5 m/s	0.8... 16.0 l/min
G 1 male	15 mm	approx. 3.0 m/s	1.6...32.0 l/min
		approx. 4.7 m/s	2.5... 50 l/min
G 1½ male	20 mm	approx. 3.3 m/s	3.2... 63 l/min
		approx. 5.3 m/s	5.0... 100 l/min
G 2 male	32 mm	approx. 3.3 m/s	8... 160 l/min
		approx. 6.6 m/s	16... 320 l/min
G 2¾ male	54 mm	approx. 3.6 m/s	25... 500 l/min
		approx. 5.1 m/s	35... 700 l/min



MIK-...F300, MIK-...F390

Impulse output: PNP, Open Collector, max. 200 mA
500 Hz at full scale (...F300)
50...1000 Hz at full scale (...F390)
factory set as per customer request

Power supply: 24 V_{DC} ±20%

Power consumption: 60 mA

Electrical connection: plug M 12 x 1

MIK-...S300, MIK-...S30D

Display: duo-LED for switch status

Switching output: relay SPDT, max. 1A/30V_{DC}
or aktive 24 V_{DC}, N/C / N/O

Switch point: 10...100% of full scale in
10%-steps that can be configured
by the customer using a rotary
switch

Power supply: 24 V_{DC} ±20%

Power consumption: 80 mA

Electrical connection: plug M 12 x 1.5-pin

MIK-...L303; MIK-...L343

Output: 0(4)-20 mA, 3-wire

Max. load: 500 Ω

Power supply: 24 V_{DC} ±20%

Power consumption: 80 mA

Electrical connection: plug M 12 x 1

MIK-...L443 (usage with AUF-3000)

Output: 4-20 mA, 3-wire

Max. load: 500 Ω

Power supply: 24 V_{DC} ±20%

Power consumption: 80 mA

Electrical connection: plug DIN 43650

MIK-...C3T0 (U-PACE electronics)

Supply voltage: 19-30 V_{DC}, internal power
consumption max. 200 mA

Display: TFT display, 128x128 pixels,
1.4" display orientation in
90° steps adjustable

Display repetition rate: 0.5... 10 s, adjustable

Pulse output: Push-Pull, freely scalable,
configurable for partial and
accumulated totaliser

Frequency output: Push-Pull, freely scalable,
2 kHz @ overflow
f_{min} @ FS = 50 Hz
f_{max} @ FS = 1000 Hz

Alarm output: NPN, PNP, Push-Pull,
configurable max. 30 V_{DC},
max. 200 mA short-circuit proof

Analogue output: active, 3 wire, 0(4)-20 mA,
max. load 500 Ω or 0(2)-10 V_{DC},
(R_i = 500 Ω)
(factory calibrated with R_L = 1 MΩ)

Control input: active signal U_{high} max. 30 V_{DC}
0 <Low <10 V_{DC}
15 V_{DC} <High <Vs

Dosing function: Dosing output OUT2:
Push-Pull, High active
Control input OUT1:
START/STOP 0.5 s <t_{high} <4 s
RESET t_{high} >5 s

Electrical connection: plug M12x1, 4-pin

Shock resistance
DIN EN 60068-2-27:2010:20 g (11 ms)

Vibration resistance
DIN EN 60068-2-6:2008: 5 g (10...2000 Hz)

Environmental testing
DIN EN 60068-2-30:2006:severity level b

When operated under the CSA Label, the equipments shall be supplied with an external power supply which fulfils the requirements of Cl. 6.3.1, 6.3.2, 9.4 of IEC/CSA/UL 61010-1 and fulfils the requirements of the national authorities. For example, by the use of a Class 2 Limited Power Source (LPS)

Configuration of outputs

Output 1 (OUT1, PIN 4)	Output 2 (OUT2, PIN 2)
Analogue output 4-20 mA	Analogue output 4-20 mA
Analogue output 0-20 mA	Analogue output 0-20 mA
Analogue output 2-10 V	Analogue output 2-10 V
Analogue output 0-10 V	Analogue output 0-10 V
Switching output NPN/PNP/PP	Switching output NPN/PNP/PP
Pulse output PP	Pulse output PP
Frequency output PP	Frequency output PP
Communication mode KofCom	
Communication mode IO-Link	
Control input	
Control input dosing function	Dosing output

IO-Link specification

Manufacturer ID: 1105 (decimal), 0 x 0451 (hex)

Manufacturer name: Kobold Messring GmbH

IO-Link specification: V1.1

Bitrate: COM3

Minimal cycle time: 1,1 ms

SIO-Mode: yes (OUT1 in configuration IO-Link)

Block parameterisation: yes

Operational readiness: 10 s

Max. cable length: 20 m



Electrical Connections

MIK-...S300

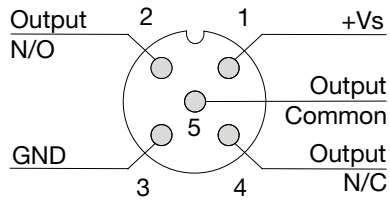

MIK-...S30D

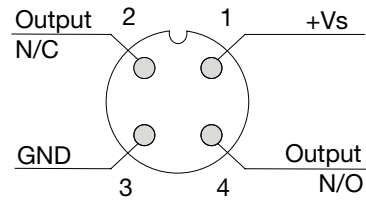

MIK-...L3x3, MIK-...F3x0

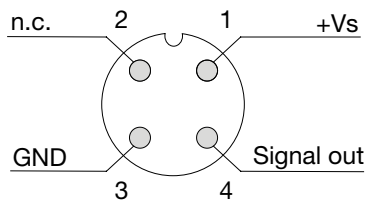

MIK-...L443

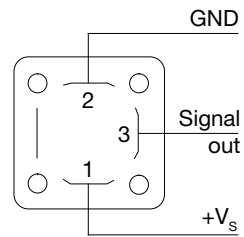

MIK-...C3T0

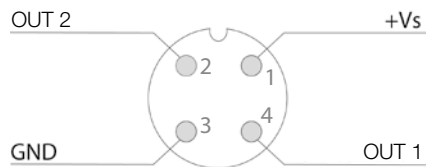



Order Details (Example: MIK-5NA 10 A F300)

Model	Range	Connection set	Electronics
MIK-5NA.. = PPS-housing, NBR-seal, stainless steel-electrode	..08.. = 10...500 ml/min, G ½ ..10.. = 0.05...1.0 l/min, G ½ ..15.. = 0.16...3.2 l/min, G ½	..A.. = without ¹⁾ ..P.. = PVC-hose connection ..E.. = stainless steel-weld-on ends	Frequency output ..F300 = M12-plug, 500 Hz ..F390 = M12-plug, 50...1000 Hz ²⁾
	MIK-5VA.. = PPS-housing, FPM-seal, stainless steel-electrode	..20.. = 0.5...10.0 l/min, G ¾ ..25.. = 0.8...16.0 l/min, G ¾	
MIK-5NC.. = PPS-housing, NBR-seal, Hastelloy®-electrode	..30.. = 1.6...32.0 l/min, G 1 ..35.. = 2.5...50.0 l/min, G 1		Switching output ..S300 = relay, M12-plug ..S30D = active 24 V _{DC} , M12-plug
MIK-5VC.. = PPS-housing, FPM-seal, Hastelloy®-electrode	..50.. = 3.2...63 l/min, G 1½ ..55.. = 5.0...100 l/min, G 1½		Analogue output ..L303 = M12-plug, 0 - 20 mA ..L343 = M12-plug, 4 - 20 mA ..L443 = DIN-plug, 4 - 20 mA
MIK-6FC.. = PVDF-housing, FFKM-seal, Hastelloy®-electrode		..A.. = without ¹⁾ ..K.. = PVC-glue connection ..E.. = stainless steel-weld-on ends	U-PACE electronics ..C3T0 = compact, TFT display, 2 outputs (current/voltage/pulse/frequency/alarm output/IO link configurable), M12x1 plug, with cCSAus and IECCE CB Scheme Approval
MIK-6FT.. = PVDF-housing, FFKM-seal, Tantalum-electrode	..60.. = 8...160 l/min, G 2 ..65.. = 16...320 l/min, G 2		
	..80.. ³⁾⁴⁾ = 25...500 l/min, G 2¾ ..85.. ³⁾⁴⁾ = 35...700 l/min, G 2¾		

¹⁾ Incl. frontal gaskets (2 pc. o-rings)

²⁾ Please specify frequency at full scale in clear text while ordering

³⁾ Not with MIK-5NC/-5VC

⁴⁾ Reduced pressure resistance of 6.5 bar for the U-PACE option with CSA and IECCE certification

Weight Sensor

Model	PPS	PVDF
MIK-...08/10/15 (½")	approx. 180 g	approx. 210 g
MIK-...20/25 (¾")	approx. 190 g	approx. 225 g
MIK-...30/35 (1")	approx. 270 g	approx. 325 g
MIK-...50/55 (1 ½")	approx. 410 g	approx. 500 g
MIK-...60/65 (2")	approx. 560 g	approx. 610 g
MIK-...80/85 (2 ¾")	approx. 1200 g	approx. 1370 g

Weight Electronics

Model	Weight
MIK-...F3x0 MIK-...S30x MIK-...Lxx3	approx. 80 g
MIK-...C3T0	approx. 300 g

Total weight = weight sensor + weight electronics



Dimensions [mm]

Model	G	L1	L2	L3	L4	L5	L6	H1	H2
MIK-xxx08A MIK-xxx10A MIK-xxx15A	G 1/2	118	90	14	46	58	36	43	28
MIK-xxx20A MIK-xxx25A	G 3/4	122	90	16	46	58	36	43	28
MIK-xxx30A MIK-xxx35A	G 1	126	90	18	46	58	36	49.5	29.5
MIK-xxx50A MIK-xxx55A	G 1 1/2	134	90	22	68	80	36	66	31.5
MIK-xxx60A MIK-xxx65A	G 2	138	90	24	68	80	36	72	36
MIK-xxx80A MIK-xxx85A	G 2 3/4	202	150	26	96	110	75	104	52

MIK-...F3x0, MIK-...S30x, MIK-...L3x3

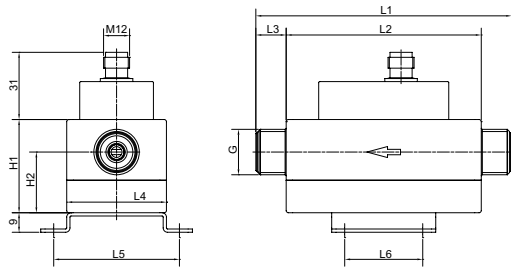

MIK-...L443

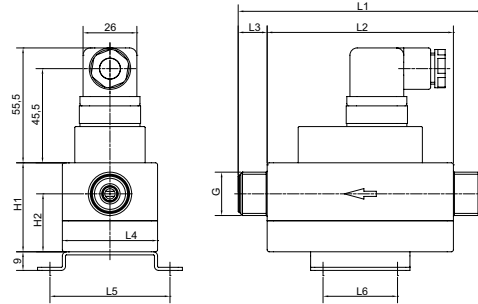

MIK-...C3T0

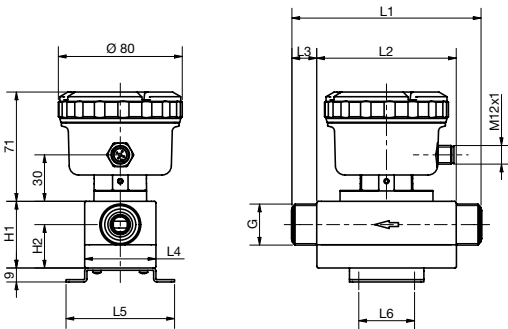

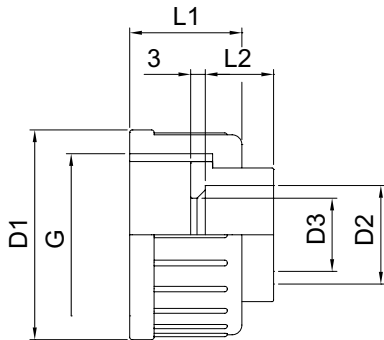

Dimensions connection set PVC-glue connection

G	D1	D2	D3	L1	L2
G 1/2	not available				
G 3/4	Ø 35	Ø 16	Ø 10.5	21	14
G 1	Ø 43	Ø 20	Ø 15	23	16
G 1 1/2	Ø 60	Ø 32	Ø 26	27	22
G 2	Ø 74	Ø 40	Ø 33	30	26
G 2 3/4	Ø 103	Ø 63	Ø 54	38	38

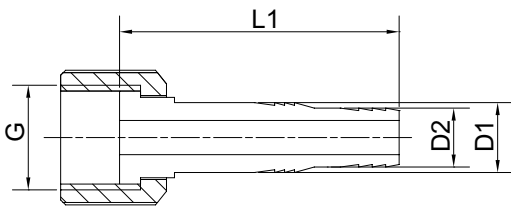

Dimensions connection set PVC-hose connection

G	D1	D2	L
G 1/2	Ø 14	Ø 12	56
G 3/4	Ø 18	Ø 16	60
G 1	Ø 22	Ø 20	67
G 1 1/2	not available		
G 2	not available		
G 2 3/4	not available		

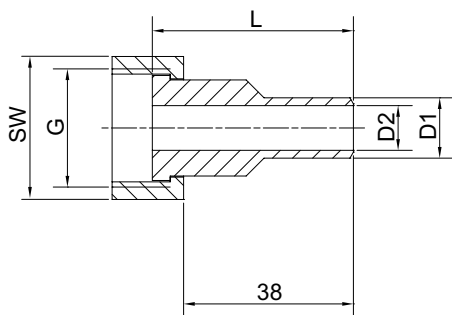

Dimensions connection set stainless steel weld-on ends

G	SW	L	D1	D2
G 1/2	24	45	Ø 10.2	Ø 5
G 3/4	32	45	Ø 13.5	Ø 10
G 1	41	45	Ø 19	Ø 15
G 1 1/2	55	60	Ø 25	Ø 20
G 2	70	60	Ø 38	Ø 32
G 2 3/4	90	60	Ø 60.3	Ø 54