



Electromagnetic Flow Meter



measuring
•
monitoring
•
analysing

MIS

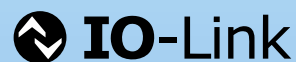

- Accuracy:
$\pm(0.5\% \text{ of reading} + 0.5\% \text{ of full scale})$
- Monitoring, transmitter function, dosing
- Bidirectional measuring
- p_{\max} : 16 bar; t_{\max} : 70 °C
- Connection flange
2", DN50, 3", DN80,
4", DN100



SS

KOBOLD companies worldwide:

AUSTRALIA, AUSTRIA, BELGIUM, BULGARIA, CANADA, CHINA, CZECHIA, FRANCE, GERMANY, GREAT BRITAIN, HUNGARY, INDIA, INDONESIA, ITALY, MALAYSIA, MEXICO, NETHERLANDS, PERU, POLAND, REPUBLIC OF KOREA, SPAIN, SWITZERLAND, THAILAND, TUNISIA, TURKEY, USA, VIETNAM

KOBOLD Messring GmbH
Nordring 22-24
D-65719 Hofheim/Ts.
Head Office:
+49(0)6192 299-0
+49(0)6192 23398
info.de@kobold.com
www.kobold.com

Description

The new flow meter MIS was developed for measuring and monitoring medium-sized flow of conductive liquids in pipes. The device operates according to the electromagnetic measurement principle. According to Faraday's Law of magnetic induction, a voltage is induced in a conductor moving through a magnetic field. The electrically conductive measuring agent acts as the moved conductor. The voltage induced in the measuring agent is proportional to the flow velocity and is therefore a value for the volumetric flow. The flowing media must have a minimum conductivity. The induced voltage is picked up by two sensing electrodes which are in contact with the measuring agent and sent to the measuring amplifier.

The flow rate will be calculated based on the cross sectional area of the pipe.

The measurement is not depending on the process liquid and its material properties such as density, viscosity and temperature. The units include a universal U-PACE electronics (Universal Precision and Control Electronics) which features two outputs arbitrarily configurable by the customer.

The U-PACE electronics offers various diagnostic functions and the following features:

- Monitoring, dosing and transmitter function
- Dosing function with external control input
- Coloured, multi-parameter configurable TFT-display, rotatable in 90° steps
- Bidirectional measuring
- Intuitive setup menu via 4 optical touch keys
- 2 configurable outputs (pulse-/frequency-/alarm- and analogue output)
- Grand and resettable totaliser
- IO link function

Significant Characteristics

- Monitoring, dosing and transmitter function
- Dosing function with external control input
- Coloured, multi-parameter configurable TFT-display, rotatable in 90° steps
- Bidirectional measuring
- Intuitive setup menu via 4 optical touch keys
- 2 configurable outputs (pulse-/frequency-/alarm- and analogue output)
- Grand and resettable totaliser
- CSA certification for Ordinary Locations (Ordloc)
- International IECCE Certification acc. to CB-Scheme with U-PACE

Areas of Application

- Water tapping
- Water treatment
- Water distribution network (leakage detection management)
- Watering
- Waste water treatment
- Filtration systems (e.g. reverse osmosis and ultrafiltration)
- Industrial applications

Technical Details

Measurement process:	electromagnetic
Range:	see flow specific values
Media:	conductive fluids
Minimum conductivity:	≥20 µS/cm
Max. medium viscosity:	70 cP
Max. pressure:	16 bar
Accuracy:	<±(0.5% of reading + 0.5% of full scale)*
Repeatability:	±0.2% of full scale
Response time flow t_{90} (alarm output / pulse output):	<250 ms
Mounting position:	in all directions
In-/outlet:	5 x DN/3 x DN
Pressure drop (max. at 3 m/s):	25 mbar
Handling:	4 optical touch fields, useable with hand gloves
Housing:	aluminium, powder coated, display screen PC

Wetted parts

Connection:	steel ASTM A105, paint coated (Corrosivity category C4M)
Lining:	NBR (others on request)
Electrodes:	Hastelloy® C276
Protection:	IP67
Media temperature:	-10 °C ... +70 °C
Ambient temperature:	-10 °C ... +60 °C

Electrical data

Supply voltage:	19 - 30 V _{DC} , internal power consumption max. 200 mA
Display:	TFT display, 128x128 pixels, 1.4" display orientation in 90° steps adjustable
Display repetition rate:	0.5 ... 10 s, adjustable
Pulse output	Push-Pull, freely scalable, configurable for partial and accumulated totaliser

* Under reference conditions: media temperature: 15 °C ... 30 °C, 1 cSt, 500 µS/cm, 1 bar
ambience temperature: 15 °C ... 30 °C



Technical Details (continued)

Frequency output Push-Pull, freely scalable,
2 kHz @ overflow
 f_{min} @ FS = 50 Hz
 f_{max} @ FS = 1000 Hz

Alarm output: NPN, PNP, Push-Pull,
configurable max. 30 V_{DC},
max. 200 mA short-circuit proof

Analogue output: active, 3 wire, 0(4)-20 mA,
max. load 500 Ω or 0(2)-10 V_{DC},
(R_i = 500 Ω)
(factory calibrated with R_L = 1 MΩ)

Control input: active signal U_{high} max. 30 V_{DC}
0 < Low < 10 V_{DC}
15 V_{DC} < High < Vs

Dosing function: Dosing output OUT2:
Push-Pull, High active
Control input OUT1:
START/STOP 0,5 s < t_{high} < 4 s
RESET t_{high} > 5 s

Electrical connection: plug M12x1, 4-pin

When operated under the CSA Label, the equipments shall be supplied with an external power supply which fulfils the requirements of Cl. 6.3.1, 6.3.2, 9.4 of IEC/CSA/UL 61010-1 and fulfils the requirements of the national authorities.
For example, by the use of a Class 2 Limited Power Source (LPS)

Flow Specific Values

DN	Size	ASME	Measuring range (m³/h)
40		1½"	0.2 ... 45
50		2"	0.3 ... 63
65		2½"	0.4 ... 100
80		3"	0.6 ... 160
100		4"	1.0 ... 250

Configuration of outputs

Output 1 (OUT1, PIN 4)	Output 2 (OUT2, PIN 2)
Analogue output 4-20 mA	Analogue output 4-20 mA
Analogue output 0-20 mA	Analogue output 0-20 mA
Analogue output 2-10 V	Analogue output 2-10 V
Analogue output 0-10 V	Analogue output 0-10 V
Switching output NPN/PNP/PP	Switching output NPN/PNP/PP
Pulse output PP	Pulse output PP
Frequency output PP	Frequency output PP
Communication mode M12 COM	
Communication mode IO-Link	
Control input	
Control input dosing function	Dosing output

IO-Link specification

Manufacturer ID: 1105 (decimal), 0 x 0451 (hex)
 Manufacturer name: Kobold Messring GmbH
 IO-Link specification: V1.1
 Bitrate: COM3
 Minimal cycle time: 1,1 ms
 SIO-Mode: yes (OUT1 in configuration IO-Link)
 Block parameterisation: yes
 Operational readiness: 10 s
 Max. cable length: 20 m

Electrical Connection MIS

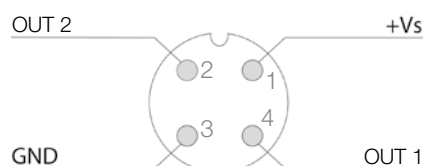



Electromagnetic Flow Meter Model MIS

Order Details (Example: MIS-H 330B1 HH 100)

Model	Material lining	Flange type/ size	Material process connection	Measuring and earthing electrodes	Transmitter mounting
MIS-	H = hard rubber	317B = DN40 PN40 form A DIN EN 1092-1 320B = DN50 PN16 form A DIN EN 1092-1 325B = DN65 PN16 form A DIN EN 1092-1 330B = DN80 PN16 form A DIN EN 1092-1 335B = DN100 PN16 form A DIN EN 1092-1 206R = 2" Class 150 FF ASME B16.5-2003 208R = 3" Class 150 FF ASME B16.5-2003 210R = 4" Class 150 FF ASME B16.5-2003 XXXX = acc. to specification	1 = steel, paint coated	HH = Hastelloy®	100 = integrated 10C = integrated, with cCSAus and IECEE CB Scheme Approval

Dimensions [mm]

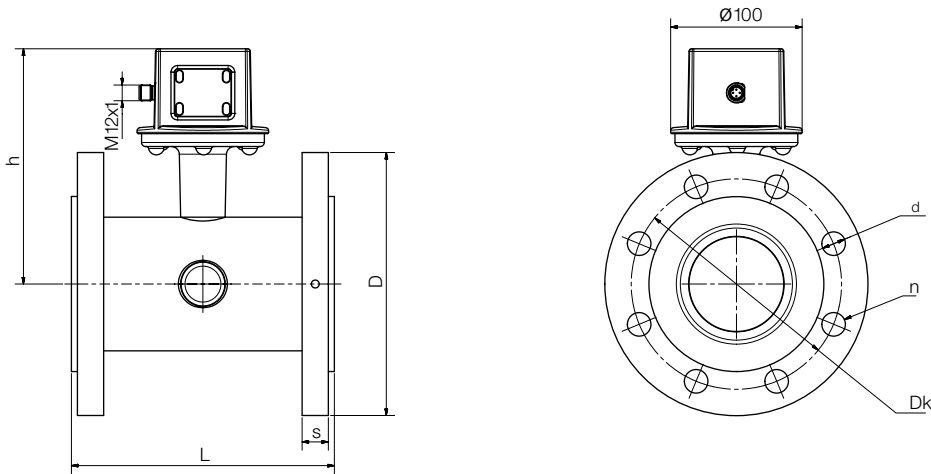

	Nominal diameter	h	L	D	s	Dk	d	n
DIN	DN50	167	200	165	20	125	18	4
	DN80	179	200	200	20	160	18	8
	DN100	186	250	220	22	180	18	8
ASME	2"	167	200	150	21	120.6	19	4
	3"	179	200	190	26	152.4	19	4
	4"	186	250	230	27	190.5	19	8

Weight

Nominal size		Pressure rating	NBR lining
[mm]	[Inch]		Weight [kg]
50	2	PN16 / Cl. 150	9.4
80	3	PN16 / Cl. 150	12
100	4	PN16 / Cl. 150	15.6



Measuring Mode, Display Layout »Single« configurable

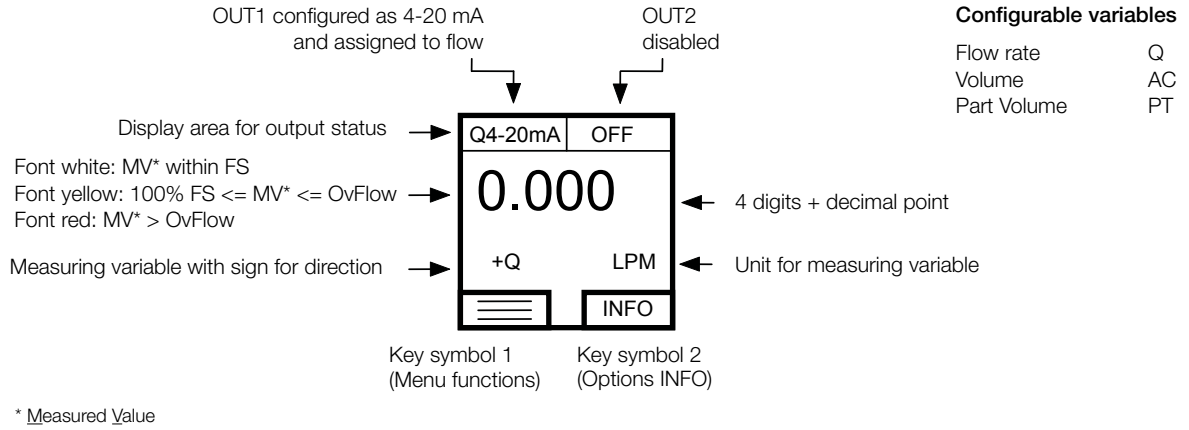

Measuring Mode, Display Layout »Dual« configurable

