



Paddle Flow Monitor for liquids



measuring
•
monitoring
•
analysing

PSR/PSE



- Switching ranges:
2.5 - 4.8 ... 383 - 533 l/min water
- p_{\max} : 250 bar, t_{\max} : 110 °C
- Connection:
G 1/4 ... G 1 1/2,
1/4" NPT ... 1 1/2" NPT
- Material:
brass or stainless steel
- Replaceable stainless steel
paddle

33



KOBOLD companies worldwide:

AUSTRALIA, AUSTRIA, BELGIUM, BULGARIA, CANADA, CHINA, CZECHIA, FRANCE, GERMANY, GREAT BRITAIN, HUNGARY, INDIA, INDONESIA, ITALY, MALAYSIA, MEXICO, NETHERLANDS, PERU, POLAND, REPUBLIC OF KOREA, SPAIN, SWITZERLAND, THAILAND, TUNISIA, TURKEY, USA, VIETNAM

KOBOLD Messring GmbH
Nordring 22-24
D-65719 Hofheim/Ts.
Head Office:
+49(0)6192 299-0
+49(0)6192 23398
info.de@kobold.com
www.kobold.com

Description

The KOBOLD flow monitor types PSE and PSR are simple, reasonably-priced and reliable monitors of fluid motions.

Depending on the flow velocity/flow throughput, the baffle plate is deflected and it moves over the balance arm the permanent magnet into the operating range of the reed contact mounted outside the process fluid.

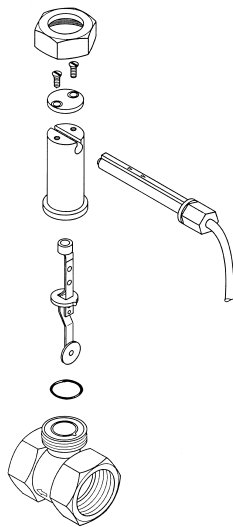

The leaf spring, which also serves as a support for the balance arm, forces the baffle plate back to its rest position when there is no flow. KOBOLD baffle plate flow monitors are supplied completely assembled with pipe length up to nominal size 40. For bigger nominal pipe sizes the devices are supplied without pipe length for direct fitting and are screwed into standard T pieces or reducing pipes. PTFE tape is used for sealing.

PSR and PSE versions

PSR made of brass or stainless steel with fitting and female thread for nominal sizes G ¼ to G 1 ½.

PSE made of brass or stainless steel with external thread for larger nominal sizes NW 50... NW 200.

Model: PSE



Model: PSR



Technical Details

Tolerance: ± 15 %
 Medium temperature:
 PS*-11/-21 (NBR) -20...+70 °C
 PS*-12 (FPM) -20...+110 °C
 PS*-22... H (FPM) -20...+110 °C
 Ambient temperature:
 all versions -20...+70 °C

Max. Pressure	Brass Version	Stainless steel Version
PSE PSR-¼...1	100 bar	250 bar
PSR-1 ¼, 1 ½	25 bar	40 bar

Protection type: IP 65
 Preferred mounting position: Upright, horizontal
 PSE-1x52/PSE-1x14: only upright
 Inlet /outlet: 5x DN in each case

Electrical Details

Bistable reed contact

- R** N/O contact/N/C contact standard
max. 2 A, max. 230 V_{AC/DC}, max. 40 W, 40 VA
- U** Changeover contact standard
max. 0.5 A, max. 150 V_{AC/DC}, max. 20 W, 20 VA
- C** N/O contact/N/C contact
2A, 20 V_{AC}, 0.18 A, 230 V_{AC}, max. 40 W
- D** Changeover contact
0.13 A, 150 V_{AC}, 0.5 A, 40 V_{AC}, max. 20 W

ATEX and IECEx

R, U N/O/N/C contact and changeover contact
 Electrical parameters depend on Zone of installation. Refer to type approval certificate for details.

Ex-range:

- | | | |
|---------------------------|----|--------------------------|
| Model PS*-**** * * * * H | or | Model PS*-**** * * * * * |
| I M1Ex ia I Ma | | Ex ia I Ma |
| II 1GEx ia IIC T3 Ga | | Ex ia IIC T4 Ga |
| II 1DEx ia IIIC T135°C Da | | Ex ia IIIC T135°C Da |
| II 2DEx ia IIIC T150°C Db | | Ex ia IIIC T110°C Db |



Materials

	PSR/PSE-11../-21..	PSR/PSE-12../-22..
Case	brass 58	st. steel 1.4301
Baffle plate	st. steel 1.4301	st. steel 1.4301
Leaf spring	st. steel 1.4310	st. steel 1.4310
Balance arm	st. steel 1.4310	st. steel 1.4310
Sleeve	brass 58	st. steel 1.4301
Magnet	oxide ceramics	oxide ceramics
Seal	NBR	FPM
Contact tube	polyamide, glass-fibre-reinforced	
Cable	PVC (standard 1.5 m)	

Applications

- Cooling and lubricant circuits
- Dry running protection for pumps
- Prevention of low water levels
- Monitoring of pipe fracture

Special advantages

- Pressure-resistant, forged case for model PSR-xx08...PSR-xx25
- Baffle plate system made of spring stainless steel
This precludes bending of paddle even with flow rates well outside the switching range
- Baffle plate exchangeable

Order Details Standard Version (Example: PSR-1108 3 R08 R 1)



Standard switch. ranges ¹⁾		Nominal size	Q _{max} l/min water	Model ³⁾		Connection	Contact	Cable length
Rising flow rate l/min water	Falling flow rate l/min water			Material brass	Material st. steel			
2.3-4.5	2-3.3	DN 8	30	PSR-1108 3...	PSR-1208 3...	R08 = G ¼ N08 = ¼" NPT	R = N/O contact (standard CE) C = N/O contact (cCSAus) U = changeover contact (standard CE) D = changeover contact (cCSAus)	PVC cable 1 = 1.5 m (standard) 2 = 2.0 m ²⁾ 4 = 3.0 m ²⁾ 6 = 4.0 m ²⁾ 8 = 5.0 m ²⁾ P = PVC cable, special length ³⁾ S = silicone cable ^{3) 4)} G = yellow PUR cable ^{3) 4)}
3-6	3-4.2	DN 10	40	PSR-1110 3...	PSR-1210 3...	R10 = G ¾ N10 = ¾" NPT		
3-6	3-5.6	DN 15	45	PSR-1115 3...	PSR-1215 3...	R15 = G ½ N15 = ½" NPT		
7.7-13.4	5-9.5	DN 20	80	PSR-1120 6...	PSR-1220 6...	R20 = G ¾ N20 = ¾" NPT		
11-17.5	11-16.5	DN 25	130	PSR-1125 8...	PSR-1225 8...	R25 = G 1 N25 = 1" NPT		
22-36	20-34	DN 32	160	PSR-1132 B...	PSR-1232 B...	R32 = G 1 ¼ N32 = 1 ¼" NPT		
38-64	38-62	DN 40	300	PSR-1140 B...	PSR-1240 B...	R40 = G 1 ½ N40 = 1 ½" NPT		



Special switch. ranges ¹⁾		Nominal size	Q _{max} l/min water	Model ³⁾		Connection	Contact	Cable length
Rising flow rate l/min water	Falling flow rate l/min water			Material brass	Material st. steel			
4.7-5.8	4.7-5.8	DN 8	30	PSR-1108 2...	PSR-1208 2...	R08 = G ¼ N08 = ¼" NPT	R = N/O contact (standard CE) C = N/O contact (cCSAus) U = Changeover contact (standard CE) D = Changeover contact (cCSAus)	PVC cable 1 = 1.5 m (standard) 2 = 2.0 m ²⁾ 4 = 3.0 m ²⁾ 6 = 4.0 m ²⁾ 8 = 5.0 m ²⁾ P = PVC cable, special length ³⁾ S = silicone cable ^{3) 4)} G = yellow PUR cable ^{3) 4)}
5.7-7.7	5.3-8	DN 8	30	PSR-1108 1...	PSR-1208 1...			
4.5-6	4.5-6	DN 10	40	PSR-1110 2...	PSR-1210 2...	R10 = G ¾ N10 = ¾" NPT		
6.2-8.5	5.6-8	DN 10	40	PSR-1110 1...	PSR-1210 1...			
6-8.1	5.9-8	DN 15	45	PSR-1115 2...	PSR-1215 2...	R15 = G ½ N15 = ½" NPT		
7.2-11	7.2-10.7	DN 15	45	PSR-1115 1...	PSR-1215 1...			
16.6-25.5	16.6-25.5	DN 20	80	PSR-1120 5...	PSR-1220 5...	R20 = G ¾ N20 = ¾" NPT		
10-24	11-24	DN 20	80	PSR-1120 4...	PSR-1220 4...			
30-47	31.1-47	DN 20	80	PSR-1120 1...	PSR-1220 1...	R25 = G 1 N25 = 1" NPT		
12-26	12-25	DN 25	130	PSR-1125 7...	PSR-1225 7...			
25-35	24.3-34.3	DN 25	130	PSR-1125 5...	PSR-1225 5...			
14-37	14-37	DN 25	130	PSR-1125 4...	PSR-1225 4...			
45-68	44-67	DN 25	130	PSR-1125 1...	PSR-1225 1...			



Standard switch. ranges ¹⁾		for pipes with diameter [mm]	Q _{max} m ³ /h water	Model ³⁾		Connection	Contact	Cable length
Rising flow rate l/min water	Falling flow rate l/min water			Material brass	Material st. steel			
68-90	61-83	50	30	PSE-1149 8...	PSE-1249 8...	R15 = G ½ N15 = ½" NPT	R = N/O contact (standard CE) C = N/O contact (cCSAus) U = Changeover contact (standard CE) D = Changeover contact (cCSAus)	PVC cable 1 = 1.5 m (standard) 2 = 2.0 m ²⁾ 4 = 3.0 m ²⁾ 6 = 4.0 m ²⁾ 8 = 5.0 m ²⁾ P = PVC cable, special length ³⁾ S = silicone cable ^{3) 4)} G = yellow PUR cable ^{3) 4)}
183-250	170-233	80	100					
320-400	300-383	100	150					
700-917	667-900	150	200					
50-62	43-58	50	30	PSE-1152 0...	PSE-1252 0...	R15 = G ½ N15 = ½" NPT		
155-183	143-167	80	100					
217-267	200-250	100	150					
558-600	517-592	150	200					
92-113	70-103	100	150	PSE-1114 9...	PSE-1214 9...	R15 = G ½ N15 = ½" NPT		
200-283	167-233	150	200					
383-533	333-467	200	200					

¹⁾ Listed values are valid only for horizontal installation ²⁾ Only for N/O contact »R« and »C«
³⁾ Length as described ⁴⁾ Only for N/O contact »R«

Order Details ATEX- and IECEx Version (Example: PSR-2208 3 R08 R 1 H)



Standard switch. ranges ¹⁾		Nominal size	Q _{max} l/min water	Model		Connection	Contact	Cable length	Special version
Rising flow rate l/min water	Falling flow rate l/min water			Material brass	Material st. steel				
2.3-4.5	2-3.3	DN 8	30	PSR-2108 3...	PSR-2208 3...	R08 = G ¼ N08 = ¼" NPT	R = N/O contact (ATEX, IECEX) U = Changeover contact (ATEX, IECEX)	PVC cable 1 = 1.5 m (standard) P = PVC cable, special length ²⁾	without = standard (not for PSx-22...) H = temperature of medium / ambient temperature +110°C (only for PSx-22...), marking acc. to certificate
3-6	3-4.2	DN 10	40	PSR-2110 3...	PSR-2210 3...	R10 = G ¾ N10 = ¾" NPT			
3-6	3-5.6	DN 15	45	PSR-2115 3...	PSR-2215 3...	R15 = G ½ N15 = ½" NPT			
7.7-13.4	5-9.5	DN 20	80	PSR-2120 6...	PSR-2220 6...	R20 = G ¾ N20 = ¾" NPT			
11-17.5	11-16.5	DN 25	130	PSR-2125 8...	PSR-2225 8...	R25 = G 1 N25 = 1" NPT			
22-36	20-34	DN 32	160	PSR-2132 B...	PSR-2232 B...	R32 = G 1 ¼ N32 = 1 ¼" NPT			
38-64	38-62	DN 40	300	PSR-2140 B...	PSR-2240 B...	R40 = G 1 ½ N40 = 1 ½" NPT			



Special switch. ranges ¹⁾		Nominal size	Q _{max} l/min water	Model		Connection	Contact	Cable length	Special version
Rising flow rate l/min water	Falling flow rate l/min water			Material brass	Material st. steel				
4.7-5.8	4.7-5.8	DN 8	30	PSR-2108 2...	PSR-2208 2...	R08 = G ¼ N08 = ¼" NPT	R = N/O contact (ATEX, IECEX) U = Changeover contact (ATEX, IECEX)	PVC cable 1 = 1.5 m (standard) P = PVC cable, special length ²⁾	without = standard (not for PSx-22...) H = temperature of medium / ambient temperature +110°C (only for PSx-22...), marking acc. to certificate
5.7-7.7	5.3-8	DN 8	30	PSR-2108 1...	PSR-2208 1...	R08 = G ¼ N08 = ¼" NPT			
4.5-6	4.5-6	DN 10	40	PSR-2110 2...	PSR-2210 2...	R10 = G ¾ N10 = ¾" NPT			
6.2-8.5	5.6-8	DN 10	40	PSR-2110 1...	PSR-2210 1...	R10 = G ¾ N10 = ¾" NPT			
6-8.1	5.9-8	DN 15	45	PSR-2115 2...	PSR-2215 2...	R15 = G ½ N15 = ½" NPT			
7.2-11	7.2-10.7	DN 15	45	PSR-2115 1...	PSR-2215 1...	R15 = G ½ N15 = ½" NPT			
16.6-25.5	16.6-25.5	DN 20	80	PSR-2120 5...	PSR-2220 5...	R20 = G ¾ N20 = ¾" NPT			
10-24	11-24	DN 20	80	PSR-2120 4...	PSR-2220 4...	R20 = G ¾ N20 = ¾" NPT			
30-47	31.1-47	DN 20	80	PSR-2120 1...	PSR-2220 1...	R20 = G ¾ N20 = ¾" NPT			
12-26	12-25	DN 25	130	PSR-2125 7...	PSR-2225 7...	R25 = G 1 N25 = 1" NPT			
25-35	24.3-34.3	DN 25	130	PSR-2125 5...	PSR-2225 5...	R25 = G 1 N25 = 1" NPT			
14-37	14-37	DN 25	130	PSR-2125 4...	PSR-2225 4...	R25 = G 1 N25 = 1" NPT			
45-68	44-67	DN 25	130	PSR-2125 1...	PSR-2225 1...	R25 = G 1 N25 = 1" NPT			



Standard switch. ranges ¹⁾		for pipes with diameter [mm]	Q _{max} m³/h water	Model		Connection	Contact	Cable length	Special version
Rising flow rate l/min water	Falling flow rate l/min water			Material brass	Material st. steel				
68-90	61-83	50	30	PSE-2149 8...	PSE-2249 8...	R15 = G ½ N15 = ½" NPT	R = N/O contact (ATEX, IECEX) U = Changeover contact (ATEX, IECEX)	PVC cable 1 = 1.5 m (standard) P = PVC cable, special length ²⁾	without = standard (not for PSx-22...) H = temperature of medium / ambient temperature +110°C (only for PSx-22...), marking acc. to certificate
183-250	170-233	80	100						
320-400	300-383	100	150						
700-917	667-900	150	200	PSE-2152 0...	PSE-2252 0...	R15 = G ½ N15 = ½" NPT			
50-62	43-58	50	30						
155-183	143-167	80	100						
217-267	200-250	100	150	PSE-2114 9...	PSE-2214 9...	R15 = G ½ N15 = ½" NPT			
558-600	517-592	150	200						
92-113	70-103	100	150						
200-283	167-233	150	200						
383-533	333-467	200	200						

¹⁾ Listed values are valid only for horizontal installation ²⁾ Length as described

Dimensions [mm]

Model: PSE-...49

Model: PSE-...52
PSE-...14

Model: PSR

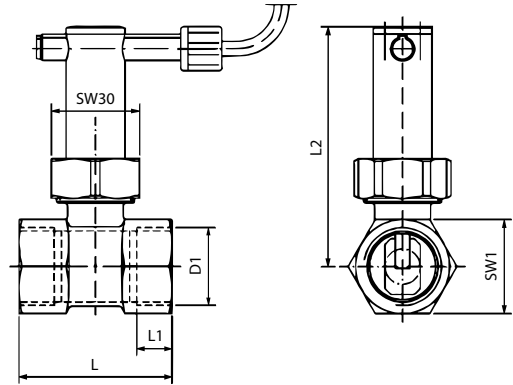
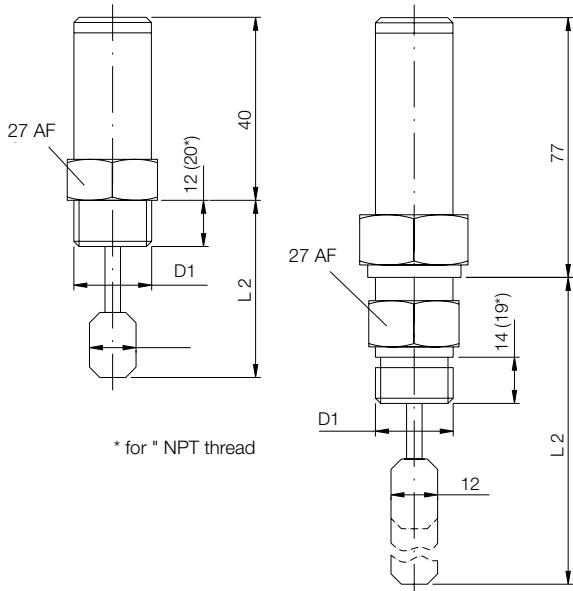

Model	D1	L ₂ [mm]
PSE-...498 R...	G 1/2	51
PSE-...520 R...	G 1/2	72
PSE-...149 R...	G 1/2	130
PSE-...498 N...	1/2" NPT	59
PSE-...520 N...	1/2" NPT	72
PSE-...149 N...	1/2" NPT	130

Model	D1	SW1		L [mm]		L1 [mm]		L2 [mm]
		G	NPT	G	NPT	G	NPT (Ms/VA)	
PSR-...08	G 1/4	27		50		12	10	80
PSR-...10	G 3/8	27		50		10	10,5	80
PSR-...15	G 1/2	27		50		12	14	80
PSR-...20	G 3/4	32		52		15	14	82
PSR-...25	G 1	39		56		15	15/17	84
PSR-...32	G 1 1/4	46	50	50	66	10	17,5	89
PSR-...40	G 1 1/2	55	60	50	66	10	17,5	92

L1 = Usable thread length

Switching point setting

To set the switching point loosen the locking washer at the top of the casing and move the contact unit. A blue, white/red arrow located on the contact unit serves as an adjustment aid.

The front edge of the locking washer serves as adjustment mark.

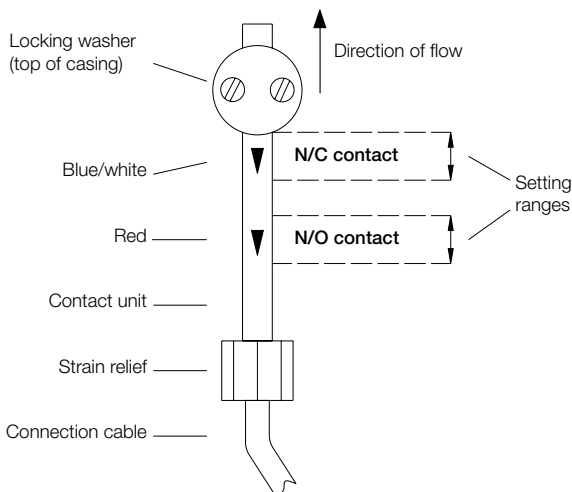

N/O contact

The switching volume can be adjusted at the red arrow. The minimum switching values specified in the table are set by moving the contact unit in the flow direction. The maximum switching values given in the table are set by moving the contact unit against the direction of flow.

N/C contact

The switching volume can be adjusted at the blue (white) arrow. The minimum switching values specified in the table are set by moving the contact unit in the flow direction. The maximum switching values given in the table are set by moving the contact unit against the direction of flow. Firmly tighten locking washer again when settings have been made.