



Ball Valves with Pneumatic Actuator

screw thread and flange connection,
welded connection



measuring
•
monitoring
•
analysing

**KUP-KA, ZA, VH,
VN, VO, VK**

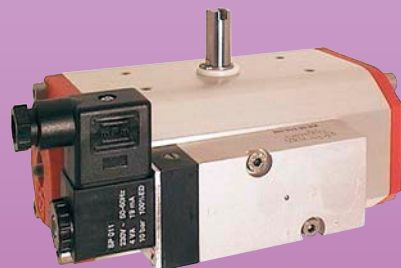
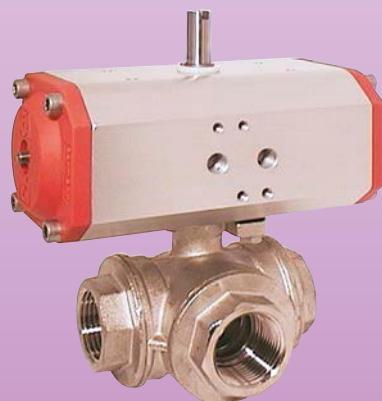

- p_{\max} : PN 16; t_{\max} : 160 °C
- Connections:
screw thread G 1/4 ... G 4
welded connection DN 15 ... DN 100
flanges DN 15 ... DN 200
- Pilot pressure: 6 ... 8 bar
- Double-acting or spring return
- Brass, stainless steel, cast iron
- 2- and 3-way version
- T and L bore
(with 3-way ball valve)



Z1

KOBOLD companies worldwide:

AUSTRALIA, AUSTRIA, BELGIUM, BULGARIA, CANADA, CHINA, CZECHIA, FRANCE, GERMANY, GREAT BRITAIN, HUNGARY, INDIA, INDONESIA, ITALY, MALAYSIA, MEXICO, NETHERLANDS, PERU, POLAND, REPUBLIC OF KOREA, SPAIN, SWITZERLAND, THAILAND, TUNISIA, TURKEY, USA, VIETNAM

KOBOLD Messring GmbH
Nordring 22-24
D-65719 Hofheim/Ts.
Head Office:
+49(0)6192 299-0
+49(0)6192 23398
info.de@kobold.com
www.kobold.com



Description

The actuator is a double-piston actuator, specially designed for operating ball valves and flaps. Two versions are available: double-acting and spring return (single-acting). The double piston design allows high torque with small external dimensions. You can adjust the angular stroke by $\pm 6^\circ$ with the standard end position.

Design

The force from the reciprocating pistons is transmitted to a pinion by two racks attached to the pistons. This arrangement delivers a linear torque characteristic across the full stroke.

Principle of operation double-acting

The space between both pistons is pressurised through point »A« forcing the pistons apart. The force of both pistons is transmitted through the racks to the pinion »C«. When pressure is applied at connection »B« and »A« is vented, both external chambers are pressurised and the pistons are forced together. You can set the angular stroke by undoing lock nuts »E« and adjusting the final stroke position setting screws »D«.

Principle of operation single-acting

The space between both pistons is pressurised through point »A« – forcing the pistons apart and forcing the springs together. The force of both pistons is transmitted through the racks to the pinion »C«. If no pressure is applied at connection »B« and »A« is vented, the pistons are forced to their home positions by the spring resistance. You can set the angular stroke by undoing lock nuts »E« and adjusting the final stroke position setting screws »D«.

Technical Details

Design:	double-piston rotary actuator, maintenance-free, pneumatic double acting or single-acting with spring return
Mounting:	four or eight DIN ISO 5211 female threads on the bottom, pinion as per DIN 3337, interface for solenoid valves and signal transmitter as per NAMUR
Materials	
Body:	aluminium alloy (anodised)
Cap:	plastic, fibre-reinforced or aluminium
Piston:	special plastic, fibre-reinforced or aluminium
Pinion:	stainless steel or steel, zinc-coated
Bearings:	smooth plastic
Gaskets:	NBR
Nuts and bolts:	stainless steel
Pilot media:	filtered air, to PNEUROP/ISO-class 4 standard at least
Temperature range:	ambient temperature -20 °C... +85 °C
Rotation:	90° (adjustable $\pm 6^\circ$)
Torque moment range:	5...300 Nm (depending on size used)
Pilot pressure:	2...10 bar
Options:	3/2- or 5/2-way electrical solenoid valve/mechanical limit switch

Actuator, adapter and ball valve are perfectly matched and supplied as a complete unit for faultless operation.

Pneumatic actuator

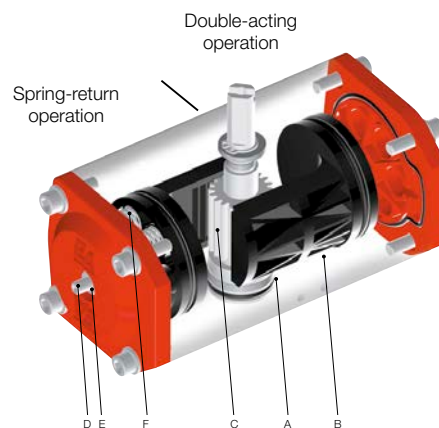
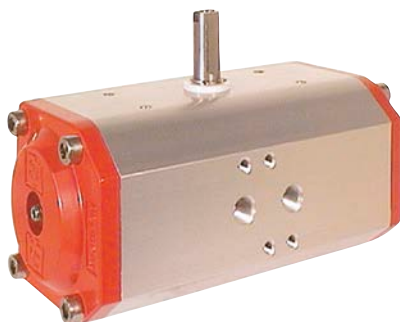

3/2-way solenoid valve for single-acting actuators



Technical Details

Design: sliding valve with manual override
 Operation: 3/2-ways
Material:
 Body: aluminium (anodised)
 Internal parts: brass and plastic
 Sealing: NBR
 Electr. connection: AC or DC with connection socket acc. to DIN 43650

Voltages: 24 V_{DC}
 230 V_{AC} 50/60 Hz
 Power consumption: AC: 7.0/4.0 VA
 DC: 4.2 W
 Duty cycle: 100 %
 Protection: IP65 acc. to VDE 0470/EN60529
 Pressure range: 3 ... 10 bar
 Medium: air
 Temperature range: -10 ... +70 °C

Dimensions [mm]

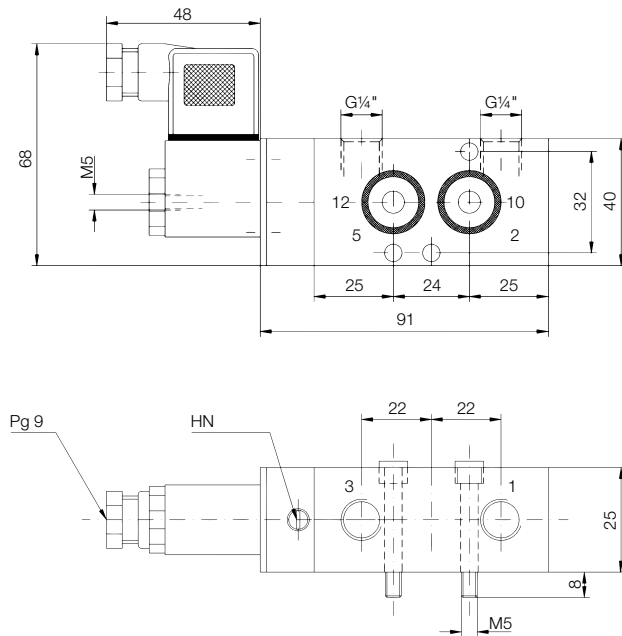

Wiring diagram

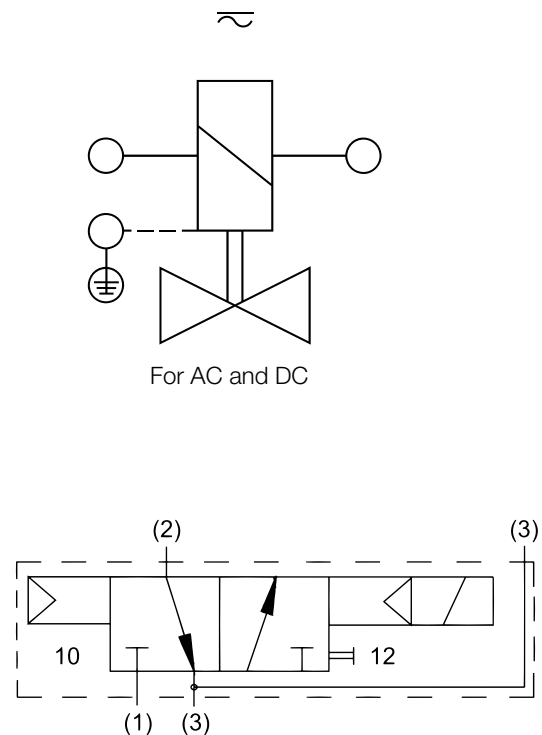

5/2-way solenoid valve for double acting actuators

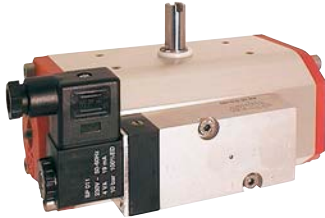

Technical Details

Design: sliding valve with manual override

Operation:

5/2-ways:

De-energised port P(1) - B(2) and A(4) - R(5) are connected. When the solenoid is energised, port P(1) - A(4) and B(2) - S(3) are connected.

Valve closes by air spring return. The exhaust air can be throttled at the ports R(5) and S(3).

Material:

Body: aluminium (anodised)

Internal parts: brass and plastic

Sealing: NBR (Perbunan®)

Electr. connection: AC or DC with connection socket acc. to DIN 43650

Voltages: 24 V_{DC}
230 V_{AC} 50/60 Hz

Power consumption: AC: 7.0/4.0 VA
DC: 4.2 W

Duty cycle: 100 %

Protection: IP65 acc. to VDE 0470/EN60529

Medium: air

Temperature range: -10 °C...+70 °C

Dimensions [mm]

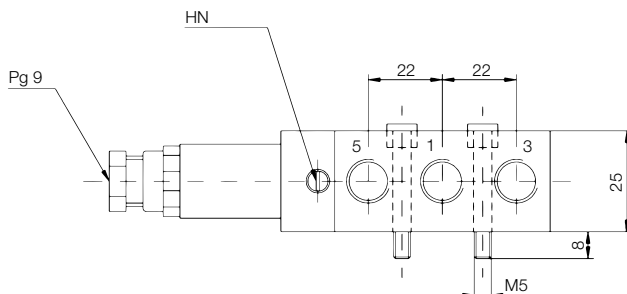
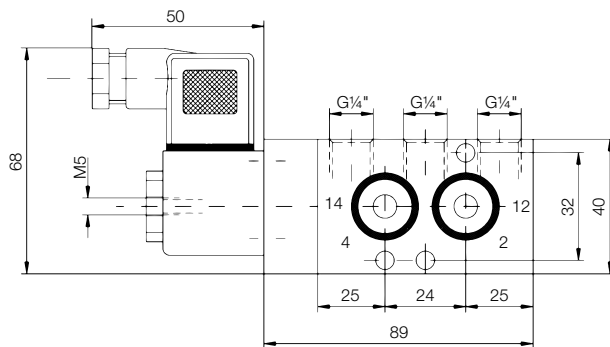

Wiring diagram

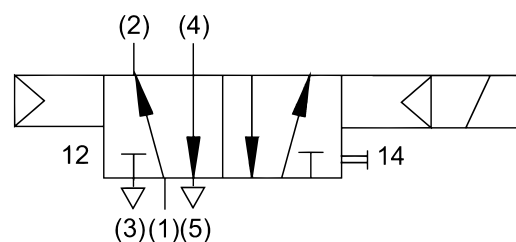
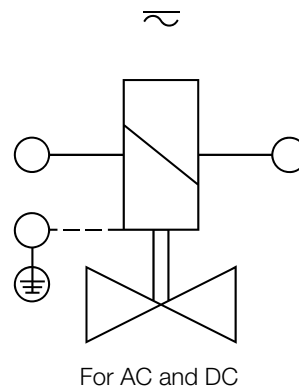

Electric-mechanic limit switches in a protective casing

IP65



Wiring diagram for IP65

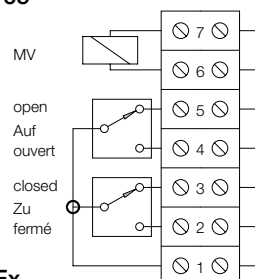

EEx



Wiring diagram for EEx

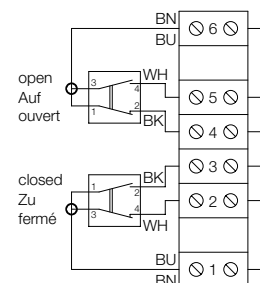

Technical Details

Design: 2 electromechanical microswitches in a protective casing
 Protection type: IP65 as per DIN 40050
 EEx d IIC T6 to EN 50014

Materials

Housing: Vestamid®, black
 Cover: Macrolon®, transparent (IP65)
 Vestamid®, black (EEx)
 Voltage rating: max. 250 V
 Electrical connection: cable gland, conduit thread PG 13,5
 Contact rating: max. 16 A (IP65)
 max. 6 A (EEx)
 Switching function: two N/O / N/C contacts
 Temperature: -20 °C ... +100 °C (IP65)
 -20 °C ... +85 °C (EEx)

Dimensions

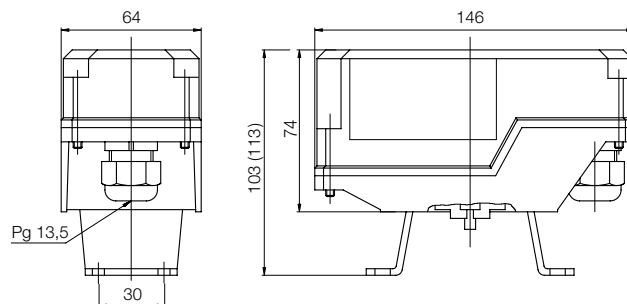



2-Way Brass Ball Valve with Pneumatic Actuator Model KUP-KA

Design

Two-piece threaded joint body design with full cylindrical bore and mounting pad for actuator mounting. With stamping as per ISO 5200 instructions A4.

Operation: pneumatic single- or double-acting
 Pilot pressure: 6... 8 bar
 Pilot media: filtered air
 Mounting position: any
 Options: 3/2- or 5/2-way solenoid valve electric /mechanic limit switches

KUP-KA

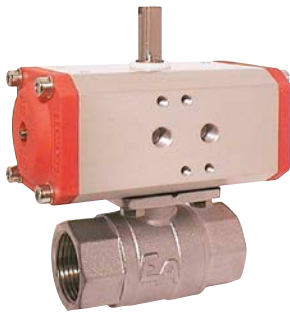

Technical Details Flow Fitting

Connections: female thread Rp 1/2 ... Rp 4 (nach DIN 2999)

Temperature range: -30 °C ... +120 °C

Nominal pressure: PN 16

Materials

Body: brass, nickel-plated

Ball: brass, hard-chrome plated

Ball gaskets: PTFE/FKM

Spindle gasket: FKM

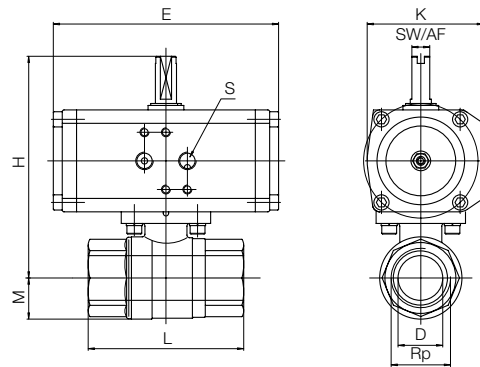

Dimensions

Screw thread [Rp]	D [mm]	L [mm]	H ¹⁾ [mm]	H ²⁾ [mm]	M [mm]	E ¹⁾ [mm]	E ²⁾ [mm]	K ¹⁾ [mm]	K ²⁾ [mm]	S [G]	SW/AF ¹⁾ [mm]	SW/AF ²⁾ [mm]	Weight ¹⁾³⁾ [kg]	Weight ²⁾³⁾ [kg]
1/2	15	65	116	116	16	126	126	65	65	1/8	10	10	1.2	1.2
3/4	20	75	121	121	19	126	126	65	65	1/8	10	10	1.3	1.3
1	24	86	124	138	23	126	163	65	78	1/8	10	10	1.6	2.1
1 1/4	30	95	129	143	28	126	163	65	78	1/8	10	10	1.8	2.4
1 1/2	38	100	157	171	35	163	193	78	86	1/8	10	10	2.5	4.2
2	47	120	164	178	42	163	193	78	86	1/8	10	10	3.4	5.1
2 1/2	64	195	197	212	57	193	231	100	115	1/4	10	10	6.4	7.6
3	76	188	207	222	68	193	231	100	115	1/4	10	10	9.3	10.5
4	95	225	242	270	78	231	260	115	143	1/4	10	19	-	-

¹⁾ Double-acting actuator ²⁾ Single-acting actuator ³⁾ Weight without springs

Order Details (example: KUP-KA R15 C A 0)

Model	Connection size	Actuation	Solenoid valve	Limit switch
KUP-KA	R15 = Rp 1/2 R20 = Rp 3/4 R25 = Rp 1 R32 = Rp 1 1/4 R40 = Rp 1 1/2 R50 = Rp 2 R65 = Rp 2 1/2 R80 = Rp 3 R1H = Rp 4	C = single-acting, default CLOSED O = single-acting, default OPEN D = double-acting	A = without B = 3/2-way (24 V _{DC}) C = 3/2-way (230 V _{AC})	0 = without 2 = 2 limit switches
			F = 5/2-way (24 V _{DC}) G = 5/2-way (230 V _{AC})	



Design

Three-piece threaded joint body design with full cylindrical bore.

Operation: pneumatic single- or double-acting

Pilot pressure: 6...8 bar

Pilot media: filtered air

Mounting position: any

Options: 3/2- or 5/2-way solenoid valve electric /mechanic limit switches

KUP-ZA

Technical Details Flow Fitting

Connections: female thread G 1/2... G 4
welded connection DN 15... DN 100

Temperature range: -30 °C...+110 °C

Nominal pressure: PN 16

Materials

Body: stainless steel 1.4408

Ball: stainless steel 1.4408

Ball gaskets: PTFE glass-fibre-reinforced

Spindle gasket: PTFE/FKM

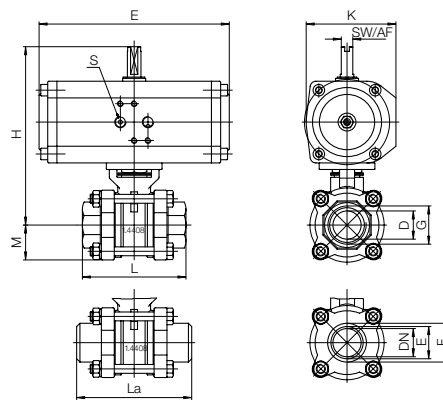
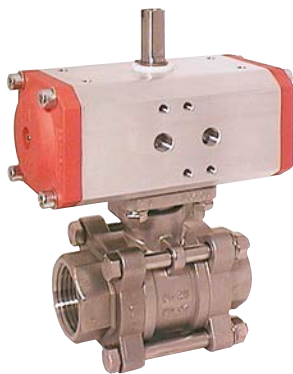

Dimensions

Screw thread [G]	DN [mm]	Ø D [mm]	L [mm]	Ø E [mm]	Ø F [mm]	La [mm]	H ¹⁾ [mm]	H ²⁾ [mm]	M [mm]	E ¹⁾ [mm]	E ²⁾ [mm]	K ¹⁾ [mm]	K ²⁾ [mm]	S [G]	SW/AF ¹⁾ [mm]	SW/AF ²⁾ [mm]	Weight ¹⁾³⁾ [kg]	Weight ²⁾³⁾ [kg]
1/2	15	15	75	18	21.3	75	134	148	22.5	126	163	65	78	1/8	10	10	1.5	2.0
3/4	20	20	80	26	26.9	90	139	153	27.0	126	163	65	78	1/8	10	10	1.8	2.3
1	25	25	90	28	33.7	100	161	175	30.0	163	197	78	86	1/8	10	10	2.5	3.0
1 1/4	32	32	110	36	42.0	110	166	180	36.5	163	197	78	86	1/8	10	10	3.5	3.5
1 1/2	40	40	120	43	48.3	125	193	205	40.5	197	193	86	100	1/8	10	10	4.5	6.2
2	50	50	140	54	60.3	150	200	227	50.0	197	231	86	115	1/8	10	10	7.7	8.9
2 1/2	65	65	185	70	76.1	190	230	273	72.5	193	266	100	143	1/4	10	19	12.9	-
3	80	80	205	82	88.9	220	256	284	89.0	231	266	115	143	1/4	10	19	19.1	-
4	100	100	240	106	114.3	270	307	-	102.0	266	-	143	-	1/4	19	-	27.4	-

¹⁾ Double-acting actuator ²⁾ Single-acting actuator ³⁾ Weight without springs

Order Details (example: KUP-ZA R15 C A 0)

Model		Connection size	Actuation	Solenoid valve	Limit switch
KUP-ZA	female thread	R15 = G 1/2 R20 = G 3/4 R25 = G 1 R32 = G 1 1/4 R40 = G 1 1/2 R50 = G 2 R65 = G 2 1/2 R80 = G 3 R1H = G 4	C = single-acting, default CLOSED O = single-acting, default OPEN	A = without B = 3/2-way (24 V _{DC}) C = 3/2-way (230 V _{AC})	0 = without 2 = 2 limit switches
	welded connection	W15 = DN 15 W20 = DN 20 W25 = DN 25 W32 = DN 32 W40 = DN 40 W50 = DN 50 W65 = DN 65 W80 = DN 80 W1H = DN 100	D = double-acting	F = 5/2-way (24 V _{DC}) G = 5/2-way (230 V _{AC})	



2-Way Stainless Steel Ball Valve with Pneumatic Actuator Model KUP-VH

Design

Two-piece threaded joint body design with full cylindrical bore.

Operation: pneumatic single- or double-acting

Pilot pressure: 6...8 bar

Pilot media: filtered air

Mounting position: any

Options: 3/2- or 5/2-way solenoid valve electric /mechanic limit switches

KUP-VH

Technical Details Flow Fitting

Connections: female thread G 1/2... G 2

Temperature range: -20 °C...+110 °C

Nominal pressure: PN 16

Materials

Body: stainless steel 1.4408

Ball: stainless steel 1.4401

Ball gaskets: PTFE

Spindle gasket: PTFE/FKM

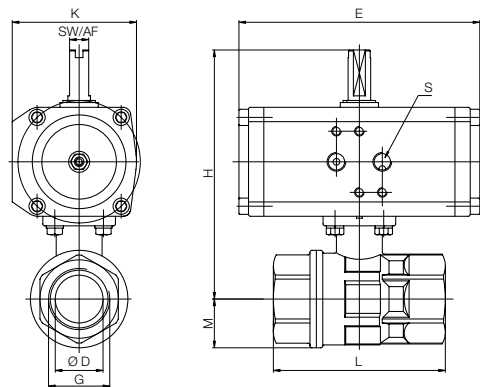

Dimensions

Screw thread [G]	Ø D [mm]	L [mm]	H ¹⁾ [mm]	H ²⁾ [mm]	M [mm]	E ¹⁾ [mm]	E ²⁾ [mm]	K ¹⁾ [mm]	K ²⁾ [mm]	S [G]	SW/AF [mm]	Weight ¹⁾³⁾ [kg]	Weight ²⁾³⁾ [kg]
1/2	15	67	118	132	17	126	163	65	78	1/8	10	1.2	1.7
3/4	20	78	120	134	21	126	163	65	78	1/8	10	1.4	2.0
1	24	90	130	144	26	126	163	65	78	1/8	10	1.9	2.4
1 1/4	32	100	134	162	32	126	197	65	86	1/8	10	2.2	2.8
1 1/2	40	112	162	188	39	163	193	78	100	1/8	10	3.6	5.2
2	50	135	171	197	49	163	193	78	100	1/8	10	4.8	6.5

¹⁾ Double-acting actuator ²⁾ Single-acting actuator ³⁾ Weight without springs

Order Details (example: KUP-VH R15 C A 0)

Model	Connection size	Actuation	Solenoid valve	Limit switch
KUP-VH	R15 = G 1/2 R20 = G 3/4 R25 = G 1 R32 = G 1 1/4 R40 = G 1 1/2 R50 = G 2	C = single-acting, default CLOSED O = single-acting, default OPEN D = double-acting	A = without	0 = without 2 = 2 limit switches
			B = 3/2-way (24 V _{DC}) C = 3/2-way (230 V _{AC}) F = 5/2-way (24 V _{DC}) G = 5/2-way (230 V _{AC})	



Design

Four-piece threaded joint body design, with mounting pad for actuator mounting, full cylindrical bore, T or L bore, universal sealing. Does not prevent crossover flow.

- Operation: pneumatic single- or double-acting
- Position: specify with order! (see table)
- Pilot pressure: 6... 8 bar
- Pilot media: filtered air
- Mounting position: any
- Options: 3/2- or 5/2-way solenoid valve electric /mechanic limit switches

Technical Details Flow Fitting

- Connections: female thread G 1/2... G 2
- Temperature range: -20 °C... +150 °C
- Nominal pressure: PN 16 (up to G 1)
PN 10 (from G 1 1/4)

Materials

- Body: brass, nickel-plated
- Ball: brass, hart chrome-plated
- Ball gaskets: PTFE
- Spindle gasket: PTFE/FKM

Positions

	T-bore				L-bore		
Handle or actuator mounting							
0° position							
90° position							

KUP-VN

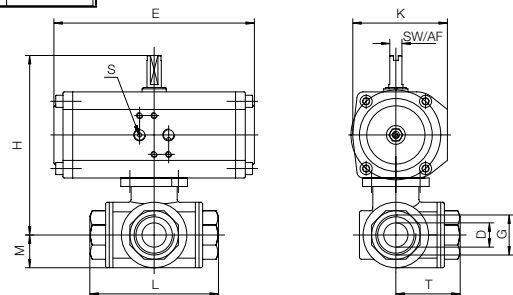

Dimensions

Screw thread [G]	Ø D [mm]	L [mm]	H ¹⁾ [mm]	H ²⁾ [mm]	M [mm]	E ¹⁾ [mm]	E ²⁾ [mm]	K ¹⁾ [mm]	K ²⁾ [mm]	S ¹⁾ [G]	S ²⁾ [G]	T [mm]	SW/AF [mm]	Weight ¹⁾³⁾ [kg]	Weight ²⁾³⁾ [kg]
1/4	8	67.0	135	135	17.0	126	126	65	65	1/8	1/8	33,5	10	1.5	1.5
3/8	10	77.0	135	135	17.0	126	126	65	65	1/8	1/8	33,5	10	1.5	1.5
1/2	15	77.0	139	153	20.0	126	163	65	78	1/8	1/8	38,5	10	1.6	2.1
3/4	20	87.0	152	166	24.0	126	163	64	78	1/8	1/8	43,5	10	1.9	2.4
1	25	105.0	179	193	30.0	163	197	78	86	1/8	1/8	52,5	10	3.1	3.1
1 1/4	32	122.5	192	206	36.0	163	197	78	86	1/8	1/8	61,3	10	4.1	5.8
1 1/2	40	138.5	221	233	43.0	197	193	86	100	1/8	1/4	69,3	10	7.6	7.6
2	50	166.0	240	267	55.5	197	231	86	115	1/8	1/4	83,0	10	11.4	12.6

¹⁾ Double-acting actuator ²⁾ Single-acting actuator ³⁾ Weight without springs

Order Details (example: KUP-VN T 1 R08 C A 0)

Model	3-way version	Position*	Connection size	Actuation	Solenoid valve	Limit switch
KUP-VN	T = T-bore	1 = standard 2 3 4	R08 = G 1/2 R10 = G 3/8 R15 = G 1/2 R20 = G 3/4 R25 = G 1	C = single-acting, default CLOSED O = single-acting, default OPEN	A = without B = 3/2-way (24 V _{DC}) C = 3/2-way (230 V _{AC})	0 = without 2 = 2 limit switches
	L = L-bore	5 = standard 6 7	R32 = G 1 1/4 R40 = G 1 1/2 R50 = G 2	D = double-acting	F = 5/2-way (24 V _{DC}) G = 5/2-way (230 V _{AC})	

* See above



2-Way Cast Iron Flange Ball Valve with Pneumatic Actuator Model KUP-VO

Design

Multipart body design with full cylindrical bore (DN 25 ... DN 125: single-part version; DN 150 ... DN 200: two-part version), with mounting pad for actuator as per ISO 5211.

Operation: pneumatic single- or double-acting
 Position: specify with order! (see table)
 Pilot pressure: 6 ... 8 bar
 Pilot media: filtered air
 Mounting position: any
 Options: 3/2- or 5/2-way solenoid valve electric /mechanic limit switches

KUP-VO



Technical Details Flow Fitting

Connections: flanges as per DIN 2533
 DN 25 ... DN 200
 overall length as per DIN 3202-F4/5
 Temperature range: -20 °C ... +160 °C
 Nominal pressure: PN 16 dimensioned, with threaded holes

Materials

Body: cast iron GG-25
 Ball: stainless steel 1.4301
 Ball gaskets: PTFE
 Spindle gasket: PTFE/FKM

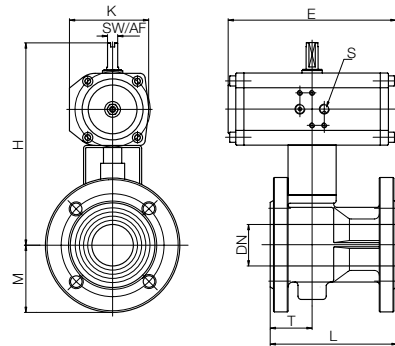

Dimensions

Flange [DN]	L [mm]	H ¹⁾ [mm]	H ²⁾ [mm]	M [mm]	E ¹⁾ [mm]	E ²⁾ [mm]	K ¹⁾ [mm]	K ²⁾ [mm]	S ¹⁾ [G]	S ²⁾ [G]	T [mm]	SW/AF ¹⁾ [mm]	SW/AF ²⁾ [mm]	Weight ¹⁾³⁾ [kg]	Weight ²⁾³⁾ [kg]
25	125	166	194	58,0	126	197	65	86	1/8	1/8	42	10	10	4.2	4.7
32	130	187	201	70,0	163	197	78	86	1/8	1/4	47	10	10	6.4	8.1
40	140	216	242	75,0	163	193	78	100	1/8	1/4	49	10	10	7.7	9.4
50	150	236	251	83,0	197	193	86	100	1/8	1/4	52	10	10	9.9	12.3
65	170	262	277	93,0	193	231	100	115	1/4	1/4	65	10	10	14.5	15.3
80	180	288	316	100,0	231	266	115	143	1/4	1/4	66	10	19	18.2	20.4
100	190	335	355	110,0	266	300	143	137	1/4	1/4	89	19	20	26.2	28.6
125	200	357	377	125,0	266	300	143	137	1/4	1/4	100	19	20	39.1	40.9
150	210	440	478	142,5	300	380	137	172	1/4	1/4	105	20	28	52.9	60.1
200	400	520	577	170,0	380	478	172	224	1/4	1/4	200	28	32	113.1	128.2

¹⁾ Double-acting actuator ²⁾ Single-acting actuator ³⁾ Weight without springs

Order Details (example: KUP-VO F25 C A 0)

Model	Connection size	Actuation	Solenoid valve	Limit switch
KUP-VO	F25 = DN 25 F32 = DN 32 F40 = DN 40 F50 = DN 50 F65 = DN 65 F80 = DN 80 F1H = DN 100 F1Z = DN 125 F1F = DN 150 F2H = DN 200	C = single-acting, CLOSED O = single-acting, OPEN	A = without	0 = without 2 = 2 limit switches
			B = 3/2-way (24 V _{DC}) C = 3/2-way (230 V _{AC})	
		D = double-acting	F = 5/2-way (24 V _{DC}) G = 5/2-way (230 V _{AC})	



Design

Single-part body design with full cylindrical bore, with mounting pad for actuator as per ISO5211. Approval to TA-Luft (German Technical Instructions on Air Quality).

- Operation: pneumatic single- or double-acting
- Position: specify with order! (see table)
- Pilot pressure: 6...8 bar
- Pilot media: filtered air
- Mounting position: any
- Options: 3/2- or 5/2-way solenoid valve electric /mechanic limit switches

Technical Details Flow Fitting

- Connections: flanges as per DIN 2533
DN 15...DN 200
- Temperature range: -20°C...+160°C
- Nominal pressure: PN 16 dimensioned, with threaded holes

Materials

- Body: stainless steel 1.4408/01
- Ball: stainless steel 1.4401
- Ball gaskets: PTFE
- Spindle gasket: PTFE/FKM

KUP-VK

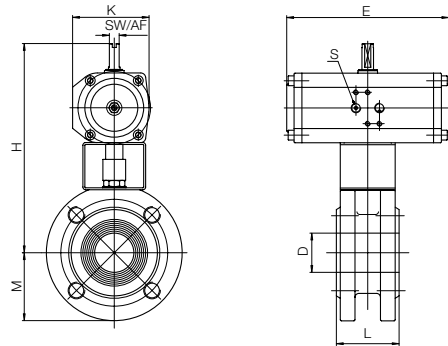

Dimensions

Flange [DN]	D [mm]	L [mm]	H ¹⁾ [mm]	H ²⁾ [mm]	M [mm]	E ¹⁾ [mm]	E ²⁾ [mm]	K ¹⁾ [mm]	K ²⁾ [mm]	S ¹⁾ [G]	S ²⁾ [G]	SW/AF ¹⁾ [mm]	SW/AF ²⁾ [mm]	Weight ¹⁾³⁾ [kg]	Weight ²⁾³⁾ [kg]
15	15	35	149	163	45.0	126	163	65	78	1/8	1/8	10	10	2.2	2.4
20	20	40	153	167	50.0	126	163	65	78	1/8	1/8	10	10	2.8	3.3
25	25	46	168	196	55.0	126	197	65	86	1/8	1/8	10	10	3.6	4.1
32	32	54	189	203	64.0	163	197	78	86	1/8	1/8	10	10	5.6	7.3
40	40	63	214	240	75.0	163	193	78	100	1/8	1/4	10	10	5.7	7.4
50	50	82	237	249	82.5	197	193	86	100	1/8	1/4	10	10	8.8	10.0
65	65	103	264	279	92.0	193	231	100	115	1/4	1/4	10	10	8.9	12.2
80	80	122	288	309	100.0	231	266	115	143	1/4	1/4	10	19	17.8	18.3
100	100	153	333	373	110.0	266	300	143	137	1/4	1/4	19	20	25.4	29.5
125	125	196	325	395	127.0	266	300	143	137	1/4	1/4	19	20	42.0	45.7
150	150	232	440	478	152.0	300	380	137	172	1/4	1/4	20	28	57.1	64.3
200	200	317	552	579	200.0	380	478	172	224	1/4	1/4	28	32	94.7	111.3

¹⁾ Double-acting actuator ²⁾ Single-acting actuator ³⁾ Weight without springs

Order Details (example: KUP-VK F15 C A 0)

Model	Connection size	Actuation	Solenoid valve	Limit switch
KUP-VK	F15 = DN 15 F20 = DN 20 F25 = DN 25 F32 = DN 32 F40 = DN 40 F50 = DN 50 F65 = DN 65 F80 = DN 80 F1H = DN 100 F1Z = DN 125 F1F = DN 150 F2H = DN 200	C = single-acting, default CLOSED O = single-acting, default OPEN	A = without	0 = without 2 = 2 limit switches
			B = 3/2-way (24 V _{DC}) C = 3/2-way (230 V _{AC})	
		D = double-acting	F = 5/2-way (24 V _{DC}) G = 5/2-way (230 V _{AC})	