



# Positive Displacement Oval Gear Flow Meter

for viscous liquids



measuring  
•  
monitoring  
•  
analysing

DON

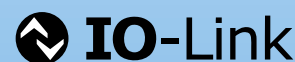

- Measuring range: 0.5 ... 36 l/h und 150 ... 2500 l/min
- Viscosity range: up to 1000 cP (standard) (higher with special cut rotors)
- Accuracy:  $\pm 0.2 \dots 1\%$  of reading
- Material: aluminium or stainless steel
- $p_{\max}$ : 100 bar;  $t_{\max}$ : 150 °C
- Pulse output, LCD display, 4...20 mA, alarms, mechanical register
- Bidirectional measuring
- U-PACE electronics: temperature measuring, IO-Link



S4

KOBOLD companies worldwide:

AUSTRALIA, AUSTRIA, BELGIUM, BULGARIA, CANADA, CHINA, CZECHIA, FRANCE, GERMANY, GREAT BRITAIN, HUNGARY, INDIA, INDONESIA, ITALY, MALAYSIA, MEXICO, NETHERLANDS, PERU, POLAND, REPUBLIC OF KOREA, SPAIN, SWITZERLAND, THAILAND, TUNISIA, TURKEY, USA, VIETNAM

KOBOLD Messring GmbH  
Nordring 22-24  
D-65719 Hofheim/Ts.  
Head Office:  
+49(0)6192 299-0  
+49(0)6192 23398  
info.de@kobold.com  
www.kobold.com

### Principle of Operation

Positive Displacement Oval Gear Flow Meters are categorised as positive displacement flow technology. When liquid flows through this type of positive displacement flow meter, two oval geared rotors measure a constant volume per rotation within a precisely machined measuring chamber. With each rotation, a constant volume of liquid is measured. The rotation of the oval wheels is sensed via magnets embedded within the rotors. These magnets transmit a high resolution pulse output.

#### Operation:

Liquid travels around the crescent shaped chambers created by the rotational movement of the rotors

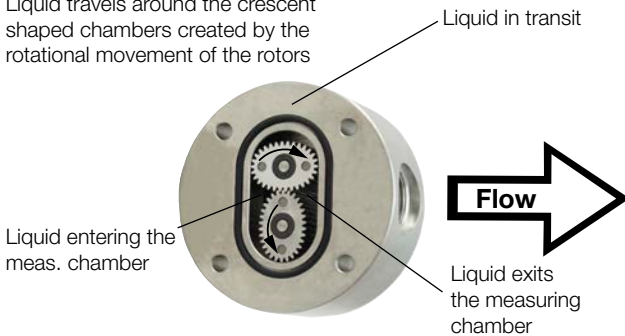

The output signal can be processed externally via a remote display controller or PLC or via a variety of output/display options available as accessories attached to the flow meters.

The positive displacement flow technology allows for precise flow measurement of most clean liquids regardless of the media conductivity. Other liquid properties also have a minimal effect on the performance of this type of meter. Flow profile conditioning is not required as with alternative flow technology options making oval gear installations simple to install in tight spaces and at an economical price.

### Areas of Application

For all viscous, non abrasive clean liquids like:

- Petroleum
- Oil
- Chemicals
- Grease
- Fuels
- Ink etc.
- Pastes

Stainless steel flow meters are suited to most products and chemicals and aluminium meters are suitable for fuels, fuel oils & lubricating liquids.

CSA certification of U-PACE electronics for Ordinary Locations (Ordloc)

International IECCE Certification acc. to CB-Scheme with U-PACE

### Technical Details

#### Material

DON-1/3

- Body: aluminium
- Oval wheels: PPS GF30/PTFE, PEEK
- Axes: stainless steel 1.4404

DON-2/4

- Body: stainless steel 1.4404
- DON-x04 ... DON-x15 stainless steel 1.4404/1.3955
- DON-x20 ... DON-x60 stainless steel 1.4404
- Oval wheels: stainless steel 1.4404
- DON-x04 ... DON-x40 stainless steel 1.3955
- DON-x45 ... DON-x60 stainless steel 1.4404

- Bearing: carbon graphite
- Axes: stainless steel 1.4404

DON-8/9

- Body: stainless steel 1.4404
- DON-x04 ... DON-x15 stainl. steel 1.4404/1.3955
- DON-x20 ... DON-x60 stainless steel 1.4404

- Oval wheels: PPS GF30/PTFE, PEEK
- Axes: stainless steel 1.4404

O-rings:

- medium temperature
- FKM: -20 ... +150 °C
- NBR: -20 ... +100 °C
- FEP-O-seal: -15 ... +120 °C
- (FEP-O-seal, FEP encased, with solid core EPDM/FKM, only for DON-x04 ... x40)
- Fluoroprene® -20 °C ... +150 °C acc. to regulation (EC) No. 1935/2004
- FKM Vi 840: -40 ... +150 °C

Cover for

- cable connection: polyamide PA6 GF35 UL94 HB/VO
- stainless steel 1.4404 (optional)

Magnet

- encapsulation: DON-x04 ... DON-x10 PEEK
- DON-x15 ... DON-x60 st. st. 1.4404

#### Material screws

For aluminium

- housing: stainless steel (standard)
- steel, coated with GEOMET® 321 (DON-A25)

For stainless steel

- housing: stainless steel (standard)
- steel, coated with GEOMET® 321 (optional) for higher pressure rating (see order details)



**Technical Details** (cont'd)

Accuracy for pulse outputs or volume counter (under reference conditions\*): ± 3 % of reading 0.5 - 3.6 l/h (DON-x04)  
 ± 1 % of reading 3.6 - 36 l/h (DON-x04)  
 ± 1 % of reading (DON-x05...DON-x15)

SS-rotors: ± 0.5 % of reading (DON-x20...DON-x60)  
 ± 0.2 % of reading (DON-x20...DON-x60;  
 with optional Z3/3A-electronics based on linearisation function)

PPS-rotors: ± 1 % of reading (DON-x20...DON-x60)  
 ± 0.5 % of reading (DON-x20...DON-x60;  
 with optional Z3/3A-electronics based on linearisation function)  
 ± 1 % of reading (option M)  
 (better accuracy for higher viscosities on request)

Additional max. inaccuracy for electrical signal outputs:

analog output 4-20 mA for -Lx and -Zx electronics: ±0.15 % full scale  
 Temperature error referenced to room temperature:  
 analog output -CT: < 200 ppm/K  
 frequency output -CT: < 100 ppm/K

Repeatability: typ. ± 0.03 %

Protection class: IP 66/67 (IP 65 for M4)

Medium temp.: -20 ... +80 °C for options Lx, Zx, M4, DON-1/3/8/9 and -20 ... +120 °C for DON-2/4 with pulse output and options Zx with cooling fins  
 -20 ... +80 °C for models with PPS/PEEK rotors  
 -40 ... +120 °C for DON-2/4 with pulse output and O-Ring FKM Vi 840

Ambient temp.: -20 ... +80 °C,  
 option M4: 0 ... +60 °C,  
 options 1A to 5A: -20 ... +60 °C  
 option CT: -20 ... +60 °C (at  $T_{medium} \leq 70 °C$ ),  
 -20 ... +45 °C (at  $T_{medium} \leq 80 °C$ )

Cable entry\*\*: M20x1.5, 1/2" NPT adapter

\* Reference conditions: x10 ... x60 (calibration oil 4.6 cSt, 25 °C, 1 bar)  
 x04/x05 and x15 for high viscosities (calibration oil 10 cSt, 20 °C, 5 bar)  
 Accuracy data is valid for given viscosities and higher.

\*\* For electronics option "CT" (electrical connection M12x1) the cable entry is plugged with a blanking plug (not used). Electrical connection M12x1 without electronics option "CT" possible with H0/B0/G0/K0/D0/L0

**ATEX-approval**

Mechanical explosion protection:  $\text{Ex}$  II 2G Ex h IIC T4/T3 Gb

Options 1A/2A/3A/5A:  
 Intrinsic safety  $\text{Ex}$  II 2G Ex ia IIC T4 Gb (-20 °C ≤ Ta ≤ +60 °C)

Options HE,DE,BE,KE,GE,LE:  
 Flameproof enclosure  $\text{Ex}$  II 2G Ex db IIC T4/T6 Gb  
 $\text{Ex}$  I M2 Ex db I Mb  
 Only St.St. Enclosure

Options HA,DA,BA,KA,GA:  
 Intrinsic safety  $\text{Ex}$  II 3G Ex ic IIC T4/T3 Gc

**IECEx-approval**

Options HE,DE,BE,KE,GE,LE:  
 Flameproof enclosure Ex db IIC  
 Ex db I Mb

**Maximum Pressure** (threaded version)

Model	Maximum pressure (bar)			
	DON-1/3	DON-2/4/8/9	DON-1/3 (Option-M4)	DON-2/8 (Option-M4)
DON-x04	64	100	-	-
DON-x05			-	-
DON-x10			-	-
DON-x15		100	-	-
DON-x20		70*	40	40
DON-x25	60*			
DON-x30	40	50	30	30
DON-x35				
DON-x40	16	16	16	16
DON-x45				
DON-x50				
DON-x55				
DON-x60				

With flanges, maximum pressure rating as above or as per flange rating, whichever is lower

\* Max. pressure rating of 100 bar possible with steel screws (see order details)

**Noise Level (in dB) at Full Scale**

Size	PPS-Oval Wheels	Stainless Steel-Oval Wheels
x25	83	91
x30	84	93,1
x35	83,5	95
x40	85,4	96
x45	87,5	98
x50	86,1	99,4
x55	86,1	98,1
x60	85	99

**Recommended Filter** (for example model MFR-DO...)

DON-x04 ... DON-x15 < 75 µm micron (200 mesh)  
 DON-x20 ... DON-x35 < 150 µm micron (100 mesh)  
 DON-x40 ... DON-x60 < 350 µm micron (45 mesh)



### Pulse Output (H0/HE/HA)

Options H0/HE/HA are equipped with a Reed switch pulse output and a Hall sensor pulse output.

#### Reed switch pulse output

The reed switch output is a two wire normally open SPST voltage free contact ideal for installations without power or for use in hazardous area locations when Intrinsically Safe (I.S.) philosophy is adopted.

**Note:** when using the reed switch output the liquid temperature must not change at a rate greater than 10°C per minute.

Average switching life of reed contact (MTTF):

max. load (30 V/10 mA)  $5 \times 10^5$  switching cycles

max. load (<5 V/10 mA)  $5 \times 10^8$  switching cycles

**Switching capacity:** max. 30 V<sub>DC</sub>, max. 20 mA

#### Hall sensor pulse output

With this signal output, a Hall Effect sensor is combined with an active push-pull output. The electrical connection is provided in 3-wire version. The output is actively switched either to +Vs or to ground. The external supply voltage is 8...30 V<sub>DC</sub>. No additional external circuit is required (e.g pull up resistor). The high signal is approximately equal to the supply voltage +Vs and the low signal is approximately 0 V. The electrical load may optionally be connected to the supply voltage or to GND.

Maximum output current (current source or sink): 100 mA (short circuit protected).

#### Hall sensor pulse output (...HU)

Like option H0, however with following deviations:

- (i) no push-pull output - only NPN output
- (ii) supply voltage 5 - 30 V<sub>DC</sub>

#### Hall sensor pulse output (...B0/BE/BA)

Like options H0/HE/HA, however with bipolar sensors and alternating polarised magnets. This option is used for pulsating flows, but it is not equipped with Reed switch and has halved K-factor as compared to H0/HE/HA.

#### High-resolution Hall sensor pulse output, (...G0/GE/GA, ...K0/KE/KA)

Like options H0/HE/HA; model DON-x05 and DON-x10 can be supplied with four times the count of pulses per liter (...G0/GE/GA) and models DON-x05, DON-x10 and DON-x15 with double amount of pulses (K0/KE/KA) (see table «Output Pulse Resolution» on the following pages).

#### Quadrature hall effect pulse output (...D0/DE/DA)

DON instrument with option D0/DE/DA is provided with two independent Hall sensors. The two Hall effect sensors are arranged to give separate outputs out of phase with one another.

The QUAD output is mostly suitable for custody transfer with redundant signal or for detecting bidirectional flows (detection of flow direction).

Maximum output current per channel (current source or sink): 100 mA (short circuit protected).

### Option L0/LE

The options L0 and LE (Exd) are available with loop powered 4-20 mA output. The loop is supplied with an external power supply 16...32 V<sub>DC</sub>. The maximum resistance of the series loads (PLC analogue input/display electronics) depends on the magnitude of the supply voltage and can be calculated as:

$$\text{Max. load [Ohm]} = (+Vs - 9 V_{DC}) / 0.02 \text{ A } [\Omega]$$

$$\text{Example: } +Vs = 32 V_{DC} \Rightarrow \text{max. load} = 1150 \Omega$$

$$+Vs = 16 V_{DC} \Rightarrow \text{max. load} = 350 \Omega$$

The load can be inserted at any point in the current loop observing correct polarity.

### Mechanical totaliser (...M4)

The flowmeters type DON-x20... up to DON-x60... are available with a 4-digit resettable mechanical totaliser and indication of accumulated total value. The motion of the rotors is transmitted to the mechanical register totaliser via an interfacing reduction gear train and dynamic seal assembly.

Option M4 is available for DON-x20...x40 for volume units litre and gallon, and for DON-x45...x60 for volume units 10 litres and 10 gallons.

Body material: enamelled die-cast aluminium, powder-coated

Protection: IP65

Ambient temp.: 0...+60°C

Medium temp.: -20...+80°C



**U-PACE electronics (...CT)**

The universal U-PACE electronics (Universal Precision and Control Electronics, order code CT) features two outputs arbitrarily configurable by the customer.

In addition, the U-PACE electronics offers various diagnostic functions and the following features:

- Flow- and temperature measurement
- Monitoring, dosing and transmitter function
- Dosing function with external control input
- Coloured, multi-parameter configurable TFT-display, rotatable in 90° steps
- Bidirectional measuring
- Intuitive setup menu via 4 optical touch keys
- 2 configurable outputs (pulse-/frequency-/alarm- and analogue output)
- Grand and resettable totaliser
- IO link function

**Materials**

Housing: aluminium for DON-1 and DON-3  
st. st. 1.4404 for DON-2,4,8,9  
Display screen: PC  
Housing screw cap: PA6

**Electrical Details U-PACE**

Supply voltage: 19-30 V<sub>DC</sub>, internal power consumption max. 200 mA  
Display: TFT display, 128x128 pixels, 1.4" display orientation in 90° steps adjustable  
Display repetition rate: 0.5... 10 s, adjustable  
Pulse output Push-Pull, freely scalable, configurable for partial and accumulated totaliser  
Frequency output Push-Pull, freely scalable, 2 kHz @ overflow  
f<sub>min</sub> @ FS = 50 Hz  
f<sub>max</sub> @ FS = 1000 Hz  
Alarm output: NPN, PNP, Push-Pull, configurable max. 30 V<sub>DC</sub>, max. 200 mA short-circuit proof  
Analogue output: active, 3 wire, 0(4)-20 mA, max. load 500 Ω or 0(2)-10 V<sub>DC</sub>, (R<sub>i</sub> = 500 Ω) (factory calibrated with R<sub>L</sub> = 1 MΩ)  
Control input: active signal U<sub>high</sub> max. 30 V<sub>DC</sub>  
0 < Low < 10 V<sub>DC</sub>  
15 V<sub>DC</sub> < High < Vs  
Dosing function: Dosing output OUT2: Push-Pull, High active  
Control input OUT1: START/STOP 0.5 s < t<sub>high</sub> < 4 s  
RESET t<sub>high</sub> > 5 s  
Response time electrical outputs: Size X05 to X20 and X45 to X60: < 1.5 s  
Size X25 to X40: < 0.5 s

**Temperature measurement**

Meas. range: -20...+80 °C  
Accuracy: ±1.0 °C (depending on ambient temperature)

**Configuration of outputs**

Output 1 (OUT1, PIN 4)	Output 2 (OUT2, PIN 2)
Analogue output 4-20 mA	Analogue output 4-20 mA
Analogue output 0-20 mA	Analogue output 0-20 mA
Analogue output 2-10 V	Analogue output 2-10 V
Analogue output 0-10 V	Analogue output 0-10 V
Switching output NPN/PNP/PP	Switching output NPN/PNP/PP
Pulse output PP	Pulse output PP
Frequency output PP	Frequency output PP
Communication mode KofiCom	
Communication mode IO-Link	
Control input	
Control input dosing function	Dosing output

**IO-Link specification**

Manufacturer ID: 1105 (decimal), 0 x 0451 (hex)  
Manufacturer name: Kobold Messring GmbH  
IO-Link specification: V1.1  
Bitrate: COM3  
Minimal cycle time: 1,1 ms  
SIO-Mode: yes (OUT1 in configuration IO-Link)  
Block parameterisation: yes  
Operational readiness: 10 s  
Max. cable length: 20 m

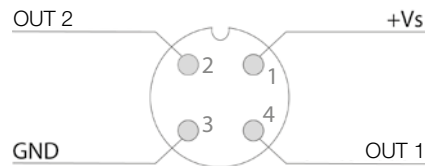

When operated under the CSA Label, the equipments shall be supplied with an external power supply which fulfils the requirements of Cl. 6.3.1, 6.3.2, 9.4 of IEC/CSA/UL 61010-1 and fulfils the requirements of the national authorities.

For example, by the use of a Class 2 Limited Power Source (LPS)



## Positive Displacement Oval Gear Flow Meter Model DON

### Electronic with LCD Display

Model	..Z1	..Z2	..Z3	..Z5	..ZE	..ZB	..1A	..2A	..3A	..5A
Function	dual totaliser	dosing unit	rate/counter				dual totaliser	dosing unit	rate/counter	rate/counter
<b>Power supply</b>										
External	5 - 28 V <sub>DC</sub>	12 - 28 V <sub>DC</sub>	5 - 28 V <sub>DC</sub>		9 - 28 V <sub>DC</sub>	-	U <sub>i</sub> = 28 V I <sub>i</sub> = 100 mA P <sub>i</sub> = 0.7 W			
Battery operation (output deactivated) <sup>2)</sup>	yes	no	yes	no	yes	yes	yes	no	yes	no
Battery included in shipment <sup>3)</sup>	yes	-	yes	-	yes	yes	yes	-	yes	-
<b>LCD display</b>										
Selectable units	yes	yes	yes	yes	yes	yes	yes	yes	yes	yes
Decimal point	yes	yes	yes	yes	yes	yes	yes	yes	yes	yes
Accumulative total	yes	yes	yes	yes	yes	yes	yes	yes	yes	yes
Resettable total	yes	yes	yes	yes	yes	yes	yes	yes	yes	yes
Linearisation	yes	no	yes	yes	yes	yes	yes	no	yes	yes
Rate display	yes	yes	yes	yes	yes	yes	yes	yes	yes	yes
Backlighting	yes	yes	yes	yes	yes	no	no	no	no	no
<b>Input</b>										
Sensors	Hall sensor/ reed switch									
<b>Outputs</b>										
4-20 mA	no	no	yes	yes	no	no	no	no	yes	yes
Flow rate alarm min./max.	no	no	NPN/PNP/PP	NPN/PNP/PP	no	no	no	no	no	with solid-state relay board
Batch end & control	no	yes	no	no	no	no	no	yes	no	no
Pulse outputs	no	no	PP	PP	PP	no	no	no	no	with solid-state relay board
2 x SPDT relays <sup>1)</sup>	no	yes	no	yes	no	no	no	with solid-state relay board	no	
<b>Installation</b>										
IP65	yes	yes	yes	yes	IP66/67	IP66/67	yes	yes	yes	yes
Cable entries	M20x1.5 / ½" NPT									
Medium temperature (Option: max. +150 °C)	-20...+80 °C									
Ambient temperature	-20... +80 °C					-20... +60 °C				
Housing material	PA6 GF35 UL94 HB/VO/PC UL94 V-2									
ATEX approval	no					yes				

<sup>1)</sup> Replaces solid state outputs, for details see data sheet ZOK

<sup>2)</sup> Battery operation only applicable with the reed switch sensor of electronics options H0/HE/HA

<sup>3)</sup> Options Z5, Z6, Z7, Z8 and Z9 are shipped without batteries



**DON Pressure Drop Curves versus Viscosity**

**DON x04 ... x15**

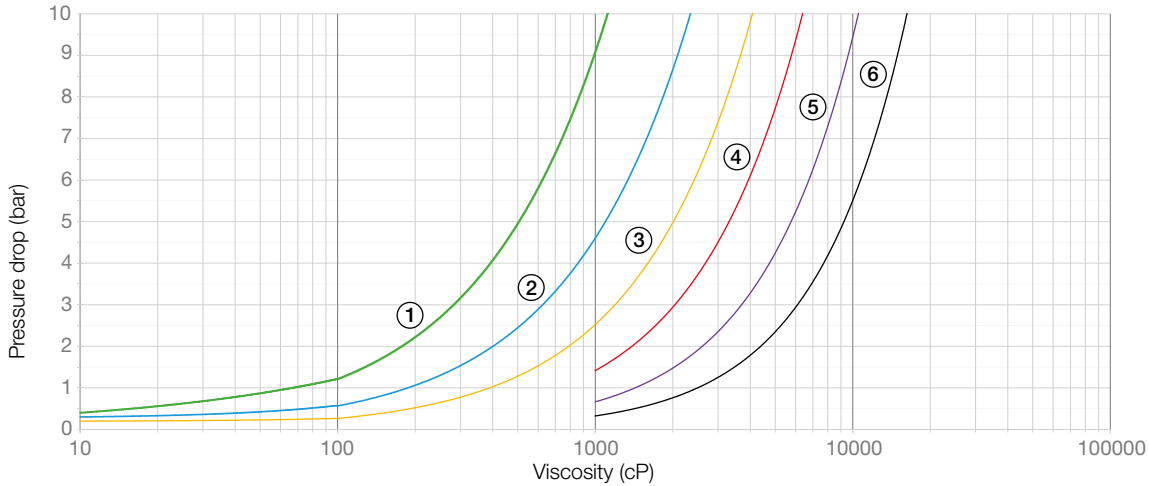

- |   |  |
|---|--|
| <p>① Standard rotors 100 % of full scale</p> <p>② Standard rotors 50 % of full scale<br/>Special cut rotors 100 % of full scale</p> <p>③ Standard rotors 25 % of full scale<br/>Special cut rotors 50 % of full scale</p> | <p>④ Standard rotors 12.5 % of full scale<br/>Special cut rotors 25 % of full scale</p> <p>⑤ Standard rotors 5 % of full scale<br/>Special cut rotors 10 % of full scale</p> <p>⑥ Standard rotors 2.5 % of full scale<br/>Special cut rotors 5 % of full scale</p> |
|---|--|

**DON x20 ... x60**

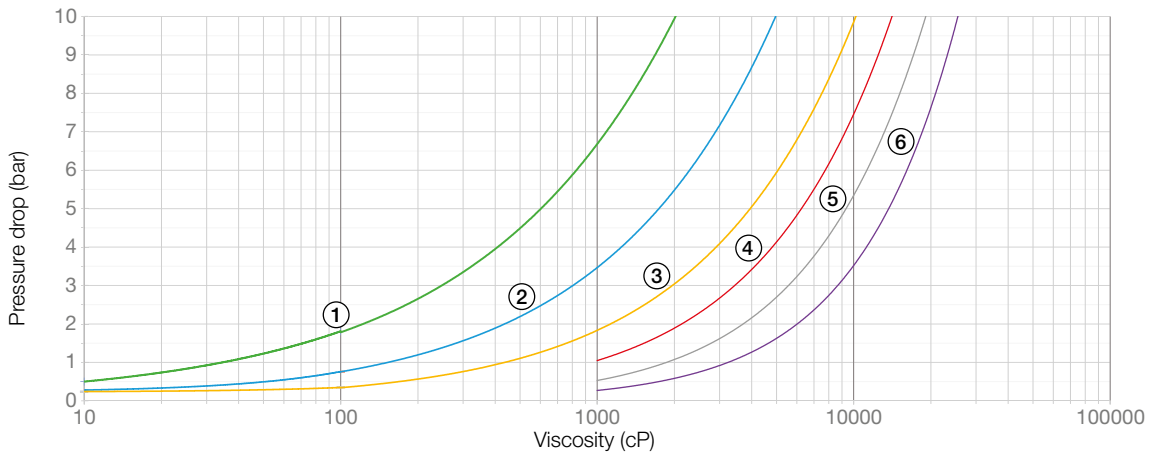

- |   |  |
|---|--|
| <p>① Standard rotors 100 % of full scale</p> <p>② Standard rotors 50 % of full scale<br/>Special cut rotors 100 % of full scale</p> <p>③ Standard rotors 25 % of full scale<br/>Special cut rotors 50 % of full scale</p> | <p>④ Standard rotors 12.5 % of full scale<br/>Special cut rotors 25 % of full scale</p> <p>⑤ Standard rotors 5 % of full scale<br/>Special cut rotors 10 % of full scale</p> <p>⑥ Standard rotors 2.5 % of full scale<br/>Special cut rotors 5 % of full scale</p> |
|---|--|

**Pressure drop limit versus flowrate**

The curves above represent the pressure drop for standard cut oval rotors. Special cut rotors of DON-3/4/9 have alternate tooth relieve which effectively reduces the pressure drop by approx. 50%.

Please note: Pressure surges are not permitted when starting up the system. Pressure surges > 3 bar can lead to blocking of the gears, especially with sizes x04 ... x15.



**Maximum Flowrate Multiplier** (for higher viscosities)

Viscosities (cP)	Standard rotor	Special cut rotor
≤ 1000	1	1
≤ 2000	0.5	1
≤ 4000	0.42	0.84
≤ 6000	0.33	0.66
≤ 8000	0.25	0.5
≤ 30000	0.15	0.3

**Special cut rotors for higher viscosities**

For viscosity > 1000 cP, special cut rotors of DON-3/4/9 should be used to reduce pressure drop. This applies to DON-x15 and larger sizes. For higher viscosities, the flow-meter max. flowrate is de-rated according to the attached chart. At viscosities <1000 cP these special rotors are less accurate.

Example: DON-x25 measuring oil at 8000 cP, max. flow 150 l/min x 0.5 = 75 l/min new maximum flow rate.

**Output Pulse Resolution**

Model	Measuring range [l/min]*	Pulse/litre					
		Reed switch Hx	Hall sensor Hx	Hall sensor Bx	Quadr. hall sensor Dx	Hall sensor, high-resolution Gx	Hall sensor, high-resolution Kx
DON-x04	0.5 - 36 l/h	2670	2670	-	2670	10680	5340
DON-x05	0.5 - 36 l/h	2670	2670	-	2670	10680	5340
DON-x10	2 - 100 l/h	1062	1062	-	2124	4248	2124
DON-x15	15 - 550 l/h	351	702	351	351	-	1404
DON-x20	1 - 40	82	163	82	82	-	-
DON-x25	10 - 150	26	104	26	26	-	-
DON-x30	15 - 250	13.5	55	13.5	13.5	-	-
DON-x35	30 - 450	6.4	25.5	6.4	6.4	-	-
DON-x40	50 - 580	4.9	19.6	4.9	4.9	-	-
DON-x45	35 - 750	2.57	10.3	2.57	2.57	-	-
DON-x50	50 - 1000	1.5	5.9	1.5	1.5	-	-
DON-x55	75 - 1500	1.05	4.2	1.05	1.05	-	-
DON-x60	150 - 2500	0.56	2.3	0.56	0.56	-	-

The values in above mentioned table are only approximate guidelines. The actual value for pulse rate can deviate from the values in this table and is mentioned in calibration certificate delivered with the flow meter.

\* The flow indicator can be reduced to a value of 0 l/min by minimizing the cutoff parameter of the U-PACE user interface. However, the accuracy of the measured value below the measuring range start value is not guaranteed.



Order Details (Example: DON-105H R1 1 L0 M 0)

Measuring range	Housing material			Connection	O-Ring Material	Electronics	Cable entry	Option
	Aluminium with PPS/PEEK <sup>12</sup> Rotor	Stainless steel	St. steel with PPS/PEEK <sup>12</sup> Rotor					
0.5-36 l/h	DON-104H	DON-204H	DON-804H	R1 = G ½	1 = FKM 3 <sup>14</sup> = FEP- O-ring 4 = NBR 5 <sup>13</sup> = Fluoro-prene <sup>®</sup> 8 <sup>15</sup> = FKM Vi 840 9 = special materials (not for ATEX)	H0 = Pulse output Hall sensor (Push/Pull) / Reed switch HU <sup>14</sup> = Pulse output Hall sensor (NPN)/Reed switch, supply 5-30 V <sub>DC</sub> B0 <sup>9</sup> = Pulse output Hall sensor (Push/Pull) for pulsating flow T0 <sup>9</sup> = Pulse output Hall sensor (Push-Pull), +150°C K0 <sup>9</sup> = Pulse output Hall sensor (Push-Pull), high resolution (x2) G0 <sup>9</sup> = Pulse output Hall sensor (Push-Pull), high resolution (x4) D0 = 2 phased outputs Hall sensor (Push-Pull) L0 = F/I transmitter, output: 4-20 mA "loop powered" analogue output Z1 = LCD dual totaliser, with battery supply outputs deactivated (ZOK-Z1) Z2 = LCD dosing unit (ZOK-Z2) Z3 = LCD totaliser, rate, outputs: 4-20 mA, alarm, pulse (ZOK-Z3) (impulses not for battery supply) Z5 = as Z3, but with 2 relays/SPDT relays Z6 = Z1 + B0 Z7 = Z3 + B0 Z8 = Z1 + D0 Z9 = Z3 + D0 ZE = LCD counter /flow (ZOE with external supply / with battery) ZB <sup>11</sup> = LCD counter /flow (ZOE without external supply /with battery) HE = H0 + ATEX (Exd) BE <sup>9</sup> = B0 + ATEX (Exd) KE <sup>9</sup> = K0 + ATEX (Exd) GE <sup>9</sup> = G0 + ATEX (Exd) DE = D0 + ATEX (Exd) LE = L0 + ATEX (Exd) HA = H0 + ATEX (Exi) BA <sup>9</sup> = B0 + ATEX (Exi) KA <sup>9</sup> = K0 + ATEX (Exi) GA <sup>9</sup> = G0 + ATEX (Exi) DA = D0 + ATEX (Exi) 1A = ZOK-E1 + HA (ATEX Exi) 2A = ZOK-E2 + HA (ATEX Exi) 3A = ZOK-E3 + HA (ATEX Exi) 5A = ZOK-E5 + HA (ATEX Exi)	M= M20 N= ½" NPT S <sup>7</sup> = M20 with cooling fin T <sup>7</sup> = ½" NPT with cooling fin P <sup>18</sup> = electrical connection M12x1	0 = without N = without battery Y = special option (specify in clear text, not for ATEX, e. g. check valve)
0.13-9.5 GPH	DON-104G	DON-204G	DON-804G	N1 = ½" NPT				
0.5-36 l/h	DON-105H	DON-205H	DON-805H	R1 = G ½				
0.13-9.5 GPH	DON-105G	DON-205G	DON-805G	N1 = ½" NPT				
2-100 l/h	DON-110H	DON-210H	DON-810H	R2 = G ¼				
0.5-27 GPH	DON-110G	DON-210G	DON-810G	N2 = ¼" NPT				
15-550 l/h	DON-115H	DON-215H	DON-815H	R3 = G ¾				
4-145 GPH	DON-115G	DON-215G	DON-815G	N3 = ¾" NPT				
1-40 l/min	DON-120H	DON-220H	DON-820H	R4 = G ½				
0.26-10.6 GPM	DON-120G	DON-220G	DON-820G	H4 <sup>9</sup> = G ½ (100 bar) N4 = ½" NPT P4 <sup>9</sup> = ½" NPT (100 bar)				
10-150 l/min	DON-125H	DON-225H	DON-825H	R6 = G 1 F6 = DIN flange, PN 16/40 (DN 25) H6 <sup>9</sup> = G 1 (100 bar) N6 = 1" NPT A6 = ANSI flange, 150 lbs (1") B6 = ANSI flange, 300 lbs (1") P6 <sup>9</sup> = 1" NPT (100 bar)				
2.6-40 GPM	DON-125G	DON-225G	DON-825G	N8 = 1½" NPT A8 = ANSI flange, 150 lbs (1½") B8 = ANSI flange, 300 lbs (1½")				
15-250 l/min	DON-130H	DON-230H	DON-830H	R8 = G 1½ F8 = DIN flange, PN 16/40 (DN 40) N8 = 1½" NPT A8 = ANSI flange, 150 lbs (1½") B8 = ANSI flange, 300 lbs (1½")				
4.0-66 GPM	DON-130G	DON-230G	DON-830G	N8 = 1½" NPT A8 = ANSI flange, 150 lbs (1½") B8 = ANSI flange, 300 lbs (1½")				
30-450 l/min	DON-135H	DON-235H	DON-835H	R9 = G 2 F9 = DIN flange, PN 16 (DN 50)				
50-580 l/min	DON-140H	DON-240H	DON-840H	C9 <sup>11</sup> = DIN flange, PN 40 (DN 50)				
8.0-120 GPM	DON-135G	DON-235G	DON-835G	N9 = 2" NPT A9 = ANSI flange, 150 lbs (2") B9 <sup>11</sup> = ANSI flange, 300 lbs (2")				
13-150 GPM	DON-140G	DON-240G	DON-840G	N9 = 2" NPT A9 = ANSI flange, 150 lbs (2") B9 <sup>11</sup> = ANSI flange, 300 lbs (2")				
35-750 l/min	DON-145H	DON-245H	DON-845H	RB = G 3 FB = DIN flange, PN 16 (DN 80)				
50-1000 l/min	DON-150H	DON-250H	DON-850H	NB = 3" NPT AB = ANSI flange, 150 lbs (3")				
10-200 GPM	DON-145G	DON-245G	DON-845G	NB = 3" NPT AB = ANSI flange, 150 lbs (3")				
13-260 GPM	DON-150G	DON-250G	DON-850G	NB = 3" NPT AB = ANSI flange, 150 lbs (3")				
75-1500 l/min	DON-155H	DON-255H	DON-855H	RC = G 4 FC = DIN flange, PN 16 (DN 100)				
20-400 GPM	DON-155G	DON-255G	DON-855G	NC = 4" NPT AC = ANSI flange, 150 lbs (4")				
150-2500 l/min <sup>10</sup>	DON-160H	DON-260H	DON-860H	RC = G 4 FC = DIN flange, PN 16 (DN 100)				
40-660 GPM	DON-160G	DON-260G	DON-860G	NC = 4" NPT AC = ANSI flange, 150 lbs (4")				

<sup>1</sup> Only for DON-235, -835 <sup>2</sup> Only for DON-x04, -x05, -x10 <sup>3</sup> Not for DON-X04, -x05, -x10 <sup>4</sup> l/min-package (nameplate l/min or ml/min, °C, bar), calibrated range and temperature °C; GPM-package (nameplate (GPM or GPH, °F, PSI)), calibrated range and temperature °F <sup>5</sup> With steel screws, only for DON-2... and DON-8... <sup>6</sup> Only for DON-x20...DON-x60. Please specify the flow direction in clear text while ordering (possible flow directions «bottom to top» or «left to right» or «right to left» only). Standard flow direction is from bottom to top <sup>7</sup> Not for electronic options 1A to 5A, not for DON-1... and DON-8... <sup>8</sup> Only for DON-2... <sup>9</sup> Only for DON-x04, -x05, -x10, -x15, without Reed switch <sup>10</sup> Calibrated up to 2200 l/min. Higher flow rate calibration on request <sup>11</sup> Without backlighting <sup>12</sup> From DON-x20 PPS <sup>13</sup> Only for DON-204...DON-230, this version is not calibrated (no calibration certificate). Use K-factor values from the data sheet. Not for ATEX <sup>14</sup> Only for DON-x04...x40. <sup>15</sup> Only for DON-204...DON-230, not for ATEX, only for pulse Output. <sup>16</sup> Only possible with electronics H0/B0/G0/K0/D0/L0



Positive Displacement Oval Gear Flow Meter Model DON

Order Details (cont'd) (Example: DON-320H R4 1 L0 M 0)

Measuring range	Housing material			Connection	O-Ring Material	Electronics	Cable entry	Option
	Aluminium with PPS/PEEK <sup>12)</sup> rotor for high viscosities	Stainless steel with rotor for high viscosities	St. steel with PPS/PEEK <sup>12)</sup> rotor for high viscosities					
15-550 l/h	DON-315H	DON-415H	DON-915H	R3 = G 3/8	1 = FKM 3 <sup>14)</sup> = FEP-O-ring 4 = NBR 5 <sup>13)</sup> = Fluoro-prene <sup>9)</sup> 8 <sup>15)</sup> = FKM Vi 840 9 = special materials (not for ATEX)	H0 = Pulse output Hall sensor (Push/Pull) / Reed switch HU <sup>14)</sup> = Pulse output Hall sensor (NPN) / Reed switch, supply 5-30 V <sub>DC</sub> B0 <sup>9)</sup> = Pulse output Hall sensor (Push/Pull) for pulsating flow T0 <sup>9)</sup> = Pulse output Hall sensor (Push-Pull), +150°C K0 <sup>9)</sup> = Pulse output Hall sensor (Push-Pull), high resolution (x2) G0 <sup>9)</sup> = Pulse output Hall sensor (Push-Pull), high resolution (x4) D0 = 2 phased outputs Hall sensor (Push-Pull) L0 = F/I transmitter, output: 4-20 mA "loop powered" analogue output Z1 = LCD dual totaliser, with battery supply outputs deactivated (ZOK-Z1) Z2 = LCD dosing unit (ZOK-Z2) Z3 = LCD totaliser, rate, outputs: 4-20 mA, alarm, pulse (ZOK-Z3) (impulses not for battery supply) Z5 = as Z3, but with 2 relays/SPDT relays Z6 = Z1 + B0 Z7 = Z3 + B0 Z8 = Z1 + D0 Z9 = Z3 + D0 ZE = LCD counter/flow (ZOE with external supply/with battery) ZB <sup>11)</sup> = LCD counter/flow (ZOE without external supply/with battery) HE = H0 + ATEX (Exd) BE <sup>9)</sup> = B0 + ATEX (Exd) KE <sup>9)</sup> = K0 + ATEX (Exd) GE <sup>9)</sup> = G0 + ATEX (Exd) DE = D0 + ATEX (Exd) LE = L0 + ATEX (Exd) HA = H0 + ATEX (Exi) BA <sup>9)</sup> = B0 + ATEX (Exi) KA <sup>9)</sup> = K0 + ATEX (Exi) GA <sup>9)</sup> = G0 + ATEX (Exi) DA = D0 + ATEX (Exi) 1A = ZOK-E1 + HA (ATEX Exi) 2A = ZOK-E2 + HA (ATEX Exi) 3A = ZOK-E3 + HA (ATEX Exi) 5A = ZOK-E5 + HA (ATEX Exi)	M = M20 N = 1/2" NPT S <sup>7)</sup> = M20 with cooling fin T <sup>7)</sup> = 1/2" NPT with cooling fin P <sup>16)</sup> = electrical connection M12x1	0 = without N = without battery Y = special option (specify in clear text, not for ATEX, e.g. check valve)
4-145 GPH	DON-315G	DON-415G	DON-915G	N3 = 3/8" NPT				
1-40 l/min	DON-320H	DON-420H	DON-920H	R4 = G 1/2 H4 <sup>9)</sup> = G 1/2 (100 bar) N4 = 1/2" NPT P4 <sup>9)</sup> = 1/2" NPT (100 bar)				
0.26-10.6 GPM	DON-320G	DON-420G	DON-920G					
10-150 l/min	DON-325H	DON-425H	DON-925H	R6 = G 1 F6 = DIN flange, PN 16/40 (DN25) H6 <sup>9)</sup> = G 1 (100 bar) N6 = 1" NPT A6 = ANSI flange, 150 lbs (1") B6 = ANSI flange, 300 lbs (1") P6 <sup>9)</sup> = 1" NPT (100 bar)				
2.6-40 GPM	DON-325G	DON-425G	DON-925G					
15-250 l/min	DON-330H	DON-430H	DON-930H	R8 = G 1 1/2 F8 = DIN flange, PN 16/40 (DN40) N8 = 1 1/2" NPT A8 = ANSI flange, 150 lbs (1 1/2") B8 = ANSI flange, 300 lbs (1 1/2")				
4.0-66 GPM	DON-330G	DON-430G	DON-930G					
30-450 l/min	DON-335H	DON-435H	DON-935H	R9 = G 2 F9 = DIN flange, PN 16 (DN50) C9 <sup>11)</sup> = DIN flange, PN 40 (DN50) N9 = 2" NPT A9 = ANSI flange, 150 lbs (2") B9 <sup>11)</sup> = ANSI flange, 300 lbs (2")				
50-580 l/min	DON-340H	DON-440H	DON-940H					
8.0-120 GPM	DON-335G	DON-435G	DON-935G					
13-150 GPM	DON-340G	DON-440G	DON-940G					
35-750 l/min	DON-345H	DON-445H	DON-945H	RB = G 3 FB = DIN flange, PN 16 (DN80) NB = 3" NPT AB = ANSI flange, 150 lbs (3")				
50-1000 l/min	DON-350H	DON-450H	DON-950H					
10-200 GPM	DON-345G	DON-445G	DON-945G					
13-260 GPM	DON-350G	DON-450G	DON-950G					
75-1500 l/min	DON-355H	DON-455H	DON-955H	RC = G 4 FC = DIN flange, PN 16 (DN100) NC = 4" NPT AC = ANSI flange, 150 lbs (4")				
20-400 GPM	DON-355G	DON-455G	DON-955G					
150-2500 l/min <sup>10)</sup>	DON-360H	DON-460H	DON-960H	RC = G 4 FC = DIN flange, PN 16 (DN100) NC = 4" NPT AC = ANSI flange, 150 lbs (4")				
40-660 GPM	DON-360G	DON-460G	DON-960G					

<sup>1)</sup> Only for DON-435, -935 <sup>2)</sup> Only for DON-x04, -x05, -x10 <sup>3)</sup> Not for DON-X04, -x05, -x10 <sup>4)</sup> l/min-package (nameplate l/min or ml/min, °C, bar), calibrated range and temperature °C; GPM-package (nameplate GPM or GPH, °F, PSI), calibrated range and temperature °F <sup>5)</sup> With steel screws, only for DON-3... and DON-9... <sup>6)</sup> Only for DON-x20...DON-x60. Please specify the flow direction in clear text while ordering (possible flow directions «bottom to top» or «left to right» or «right to left» only). Standard flow direction is from bottom to top <sup>7)</sup> Not for electronic options 1A to 5A, not for DON-3... and DON-9... <sup>8)</sup> Only for DON-4... <sup>9)</sup> Only for DON-x04, -x05, -x10, -x15, without Reed switch <sup>10)</sup> Calibrated up to 2200 l/min. Higher flow rate calibration on request <sup>11)</sup> Without backlighting <sup>12)</sup> From DON-x20 PPS <sup>13)</sup> Only for DON-415...DON-430, this version is not calibrated (no calibration certificate). Use K-factor values from the data sheet. <sup>14)</sup> Only for DON-x04...x40. <sup>15)</sup> Only for DON-415...DON-430, not for ATEX only for pulse output. <sup>16)</sup> Only possible with electronics H0/B0/G0/K0/D0/L0

**Technical Details MFR-DO (version stainless steel)**

Design: two-part screwed body  
 Connections: female thread G ¼ ... G 3  
 DIN ISO 228-1  
 Nominal pressure: PN 40  
 Temperature range: -20 °C ... +180 °C  
 Mesh size: 200 mesh/75 µm for G ¼, G ¾  
 100 mesh/150 µm for G ½, G 1, G 1½  
 40 mesh/400 µm for G 2, G 3  
 Mounting position: cover toward bottom,  
 note specified direction of flow

**Materials**

Body (1): stainless steel 1.4408, EN1503-1  
 Plug (2): stainless steel 1.4408, EN1503-1  
 Screen (4): stainless steel 316  
 Bonnet (9): stainless steel 1.4408, EN1503-1  
 Body seal (11): PTFE  
 O-ring (31): FPM

**MFR-DO**

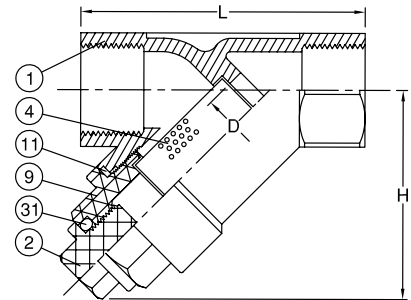

**Dimensions, weight and Order Details**

**MFR-DO stainless steel version**

(example: MFR-DOR15)

Order no.	Size		L [mm]	H [mm]	D [mm]	Weight [kg]
MFR-DOR08	DN08	¼"	65.0	51.0	10.0	0.25
MFR-DOR10	DN10	⅜"	65.0	51.0	12.0	0.25
MFR-DOR15	DN15	½"	65.0	51.0	15.0	0.25
MFR-DOR25	DN25	1"	90.0	72.0	25.0	0.70
MFR-DOR40	DN40	1½"	120.0	87.0	40.0	1.20
MFR-DOR50	DN50	2"	140.0	103.0	50.0	1.90
MFR-DOR80	DN80	3"	200.0	143.0	80.0	6.16

**Dimensions DON-1/-2/-3/-4/-8/-9**

**DON-x04 .... DON-x15**

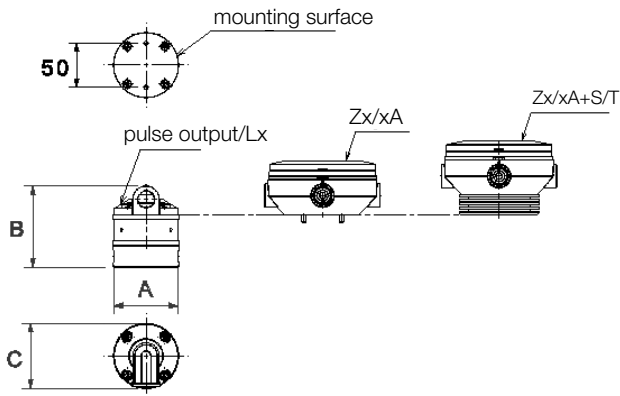

**DON-x45 .... DON-x60**

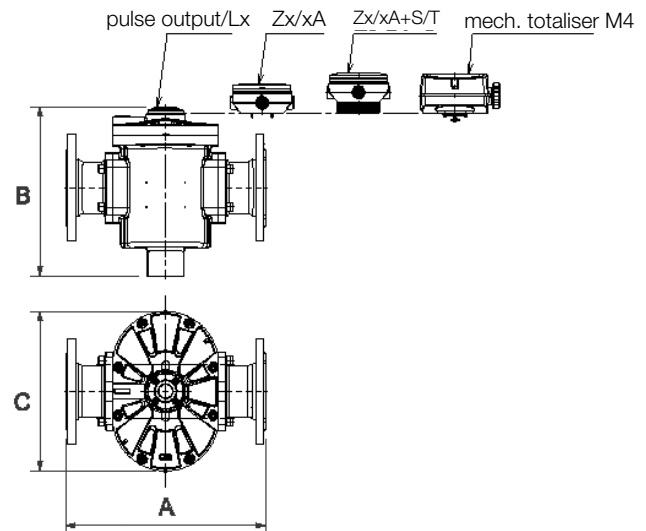

**DON-x20 .... DON-x40**

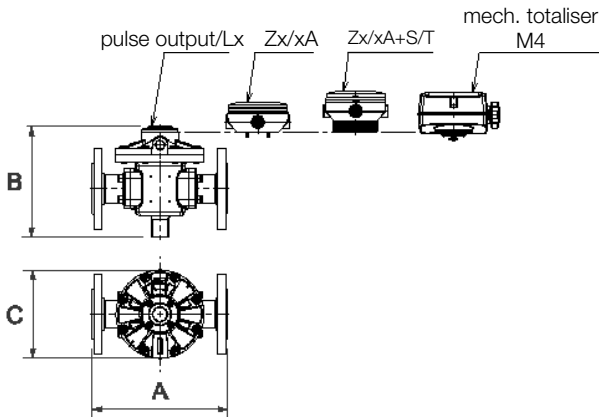

**Electronic with LCD display Zx/ xA**

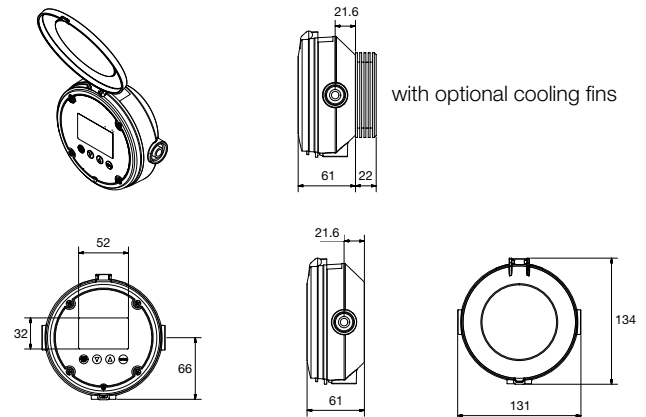

**Dimensions DON-1/-2/-3/-4/-8/-9... (± 2 mm)**

Model	A [mm]		B [mm]			C [mm]		
	Thread connection	Flange connection	Pulse output/Lx	Zx/Ex	Mechanical totaliser M4	Pulse output/Lx	Zx/Ex	Mechanical totaliser M4
DON-x04	68	-	92	131	-	72	134	-
DON-x05	68	-	92	131	-	72	134	-
DON-x10	68	-	92	131	-	72	134	-
DON-x15	68	-	99	138	-	72	134	-
DON-x20	110	-	105 (101)	134 (130)	182 (178)	112	134	165
DON-x25	176	237	136	165	194	120	134	170
DON-x30	188	252	166	195	223	163	163	200
DON-x35	212	277	172	201	244	180	180	200
DON-x40	212	277	246	275	299	180	180	200
DON-x45	266	354	232	261	284	238	238	239
DON-x50	294	382	229	258	302	290	290	290
DON-x55	294	388	274	303	347	290	290	290
DON-x60	320	414	351	380	424	331	331	331

**Note:** Dimensions for DON-2/-4/-8/-9... are specified in ( ) only when they are different from DON-1/-3...

U-PACE electronics (option DON-CT)

