

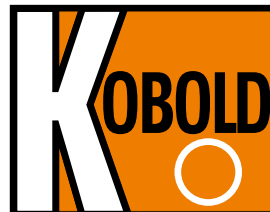

Turbine Wheel Flow Meter / Monitor

for low viscous liquids



measuring
•
monitoring
•
analysing

DOT



- Measuring range:
0.11 - 1.1 m³/h ... 270 - 2700 m³/h water
(higher on request)
- Viscosity range: low viscous
- Linearity: ±0.5 % of reading
- p_{max}: 250 bar; t_{max}: 120 °C
- Connection:
G ½ ... G 2 male, ½" NPT ... 2" NPT male,
DIN flanges DN 15 ... DN 300 (larger on
request), ANSI flanges ½" ... 12"
(larger on request)
- Material: stainless steel, carbon steel
- Output:
pulse output, LC display, 4 ... 20 mA,
batching, totalising



S4

KOBOLD companies worldwide:

AUSTRALIA, AUSTRIA, BELGIUM, BULGARIA, CANADA, CHINA, CZECHIA, FRANCE, GERMANY,
GREAT BRITAIN, HUNGARY, INDIA, INDONESIA, ITALY, MALAYSIA, MEXICO, NETHERLANDS,
PERU, POLAND, REPUBLIC OF KOREA, SPAIN, SWITZERLAND, THAILAND, TUNISIA, TURKEY,
USA, VIETNAM

KOBOLD Messring GmbH
Nordring 22-24
D-65719 Hofheim/Ts.
☎ Head Office:
+49(0)6192 299-0
☎ Sales DE:
+49(0)6192 299-500
+49(0)6192 23398
✉ info.de@kobold.com
www.kobold.com

Description

The turbine flow meter model DOT consists of a helically shaped turbine rotor supported in two tungsten carbide bearings, the rotor being solid ferritic stainless steel of a grade compatible with the metered liquid, all contained within a housing of non-magnetic stainless steel.

A pick off coil having a permanent magnet core is mounted in the housing adjacent to the rotor blade tips such that a magnetic circuit is set up via the rotor blades (Fig.1).

Rotation of the rotor varies the reluctance of this magnetic circuit and the flux changes induce a small voltage in the coil, the frequency of which is directly proportional to the rotor speed and therefore proportional to the volumetric flow rate.

The effects of increasing viscosity reduce the linear flow range and shifts the k-factor. Further, the effect of viscosity depends on the frequency (RPM of rotors). Therefore, smaller the meter, higher is the effect of viscosity on the linearity curve.

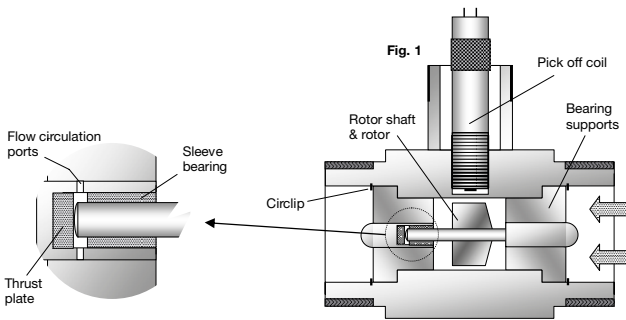

Design

The DOT is a highly accurate, reliable and robust turbine meter used to measure the flow of clean low viscosity liquids.

Stainless steel construction with tungsten carbide bearings provides long life with a wide range of aggressive and non-lubricating liquids in petrochemical and general industrial applications.

The basic meter is available with a pre-amplified square wave output. These meters have MS (military style) plug/socket for the pulse output connection.

Alternatively the meter is supplied fitted with integral instruments. These may include e.g. dual totaliser, rate counter Z3/ZE/ZB or dosing unit.

The electronics are identical to the series ZOK and ZOE. ATEX certification is not available. For further information please see the operation manual of ZOK and ZOE.

Applications

- Chemical and allied products
- Pharmaceuticals
- Deionised water
- Fuel additives
- Petrochemicals
- Plastics and hydraulics
- Water conditioning
- Other low viscous fluids

Technical Details

Sizes:	15 mm...300 mm (½" ... 12" ANSI, DN 15 ... DN 300), bigger on request (see model no. designation for information on available sizes)
Linearity at 1cP:	±0.5 % of reading, (±0.2% when utilising the linearisation feature of electronic type Z3)
Repeatability:	±0.02 ... 0.05 % under steady flow conditions
Max. pressure:	threaded connections: 250 bar flange connections: corresponding to flange specifications
Medium temperature:	-20 ... +120°C (ambient temperature max. +80°C)
Pressure drop:	approximately 0.28 bar at maximum flow (SG = 1.0, Vis. = 1 mm²/s)
Supply voltage:	see electronics
Electronic features:	see comparison table
Flanges:	according to DIN 2501 or ASME B16.5 (optional)

Materials

Housing:	stainless steel 1.4401 (316 SS)
Flanges:	stainless steel 1.4401 (316 SS) or carbon steel A106
Rotor:	SS 430 (up to DOT-xx15), SS ANC 21 (Duplex stainless steel, for bigger sizes)
Bearing support:	stainless steel 1.4401 (316 SS)
Bearings:	tungsten carbide (shaft, bush, thrust plate)



Output

Preamplifier: Inductive sensor in option »F4S« is a turbine wheel sensor with integrated preamplifier. Specially designed for turbine flow meters, the sensor provides amplified output on 3 wire.

Transmission distance: max. 500 m
Housing: stainless steel
Connector: MS acc. to MIL-DTL-5015 including mating plug with 3 x soldering pins

Power supply: 12-24 V_{DC}
Pulse output: NPN, max. 25 mA

Others: see relevant electronics datasheets ZOK/ZOE

Protection: IP55 (with option »F4S«)
 IP66/67 (with integrated electronic ZOK/ZOE)

Wire diagram

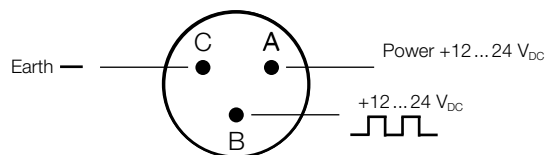

Recommended filters

Sizes up to DN50: 0.3mm (300 microns or 60 mesh)
 Sizes from DN80: 0.5mm (500 microns or 100 mesh)

Electronic with LCD Display

Model	..Z1	..Z2	..Z3	..ZE	..ZB
Function	dual totaliser	dosing unit	rate/counter		
Power supply					
Battery-powered (outputs inactive)	yes	no	yes		
External (also for backlighting)	5-28 V _{DC}	12-28 V _{DC}	5-28 V _{DC}	9-28 V _{DC}	-
LCD display					
Selectable units	yes	yes	yes	yes	yes
Decimal point	yes	yes	yes	yes	yes
Accumulative total	yes	yes	yes	yes	yes
Resettable total	yes	yes	yes	yes	yes
Linearisation	yes	no	yes	yes	yes
Rate display	yes	yes	yes	yes	yes
Backlighting	yes	yes	yes	yes	no
Outputs					
4-20 mA	no	no	yes	no	no
Flow rate alarm min./max.	no	no	NPN/PNP/PP	no	no
Batch end & control	no	yes	no	no	no
Pulse outputs	no	no	PP	PP	no
2 x SPDT relays ¹⁾	no	yes	option	no	no

¹⁾ Replaces solid state outputs, for details see data sheet ZOK



Turbine Wheel Flow Meter/Monitor Model DOT

Order Details threaded version (Example: DOT-13 15H G5 Z3M B)

Housing/ connection material	Range	Mechanical connection	Electronics/ cable entry / plug	Flow direction
DOT-13 = (st. steel/ st. steel)	05H = 0.11 - 1.1 m ³ /h	G4 = G ½ male	F4S = only pulse output preamplified/ MS (military style) connector for max. 120 °C Z1M = electronic ZOK-Z1 / M20 x 1.5 Z2M = electronic ZOK-Z2 / M20 x 1.5 Z3M = electronic ZOK-Z3 / M20 x 1.5 ZEM = electronic ZOE with external supply / with battery / M20 x 1.5 ZBM = electronic ZOE without external supply / M20 x 1.5 Z1N = electronic ZOK-Z1 / ½" NPT Z2N = electronic ZOK-Z2 / ½" NPT Z3N = electronic ZOK-Z3 / ½" NPT ZEN = electronic ZOE with external supply / ½" NPT ZBN = electronic ZOE without external supply / with battery / ½" NPT XX = special option	O = all directions (only pulse output) B = from bottom to top, indication right M = from bottom to top, indication left L = from left to right, indication on top R = from right to left, indication on top
	05G = 0.5 - 5 GPM	N4 = ½" NPT		
	10H = 0.22 - 2.2 m ³ /h	G5 = G ¾ male		
	10G = 1.0 - 10 GPM	N5 = ¾" NPT		
	15H = 0.4 - 4.0 m ³ /h	G5 = G ¾ male		
	15G = 1.8 - 18 GPM	N5 = ¾" NPT		
	20H = 0.8 - 8 m ³ /h	G5 = G ¾ male		
	20G = 3.6 - 36 GPM	N5 = ¾" NPT		
	25H = 1.6 - 16 m ³ /h	G6 = G 1 male		
	25G = 7.5 - 75 GPM	N6 = 1" NPT		
	30H = 3.4 - 34 m ³ /h	G8 = G 1 ½ male		
	30G = 15 - 150 GPM	N8 = 1 ½" NPT		
	35H = 6.8 - 68 m ³ /h	G9 = G 2 male		
	35G = 30 - 300 GPM	N9 = 2" NPT		
XXH = special option	XX = special option	XX = special option		

Order Details flanged version (Example: DOT-13 50H FE Z3M B)

Housing/ connection material	Range	Mechanical connection*	Electronics/ cable entry / plug	Flow direction
DOT-12 = (st. steel/ carbon steel) DOT-13 = (st. steel/ st. steel)	05H = 0.11 - 1.1 m ³ /h	F4 = DN 15, PN 16	F4S = only pulse output preamplified/MS (military style) connector for max. 120 °C Z1M = electronic ZOK-Z1 / M20 x 1.5 Z2M = electronic ZOK-Z2 / M20 x 1.5 Z3M = electronic ZOK-Z3 / M20 x 1.5 ZEM = electronic ZOE with external supply / M20 x 1.5 ZBM = electronic ZOE without external supply / with battery / M20 x 1.5 Z1N = electronic ZOK-Z1 / ½" NPT Z2N = electronic ZOK-Z2 / ½" NPT Z3N = electronic ZOK-Z3 / ½" NPT ZEN = electronic ZOE with external supply / ½" NPT ZBN = electronic ZOE without external supply / with battery / ½" NPT XX = special option	O = all directions (only pulse output) B = from bottom to top, indication right M = from bottom to top, indication left L = from left to right, indication on top R = from right to left, indication on top
	05G = 0.5 - 5 GPM	A4 = ½" ANSI 150 lb		
	10H = 0.22 - 2.2 m ³ /h	F5 = DN 20, PN 16		
	10G = 1.0 - 10 GPM	A5 = ¾" ANSI 150 lb		
	15H = 0.4 - 4.0 m ³ /h	F5 = DN 20, PN 16		
	15G = 1.8 - 18 GPM	A5 = ¾" ANSI 150 lb		
	20H = 0.8 - 8 m ³ /h	F5 = DN 20, PN 16		
	20G = 3.6 - 36 GPM	A5 = ¾" ANSI 150 lb		
	25H = 1.6 - 16 m ³ /h	F6 = DN 25, PN 16		
	25G = 7.5 - 75 GPM	A6 = 1" ANSI 150 lb		
	30H = 3.4 - 34 m ³ /h	F8 = DN 40, PN 16		
	30G = 15 - 150 GPM	A8 = 1 ½" ANSI 150 lb		
	35H = 6.8 - 68 m ³ /h	F9 = DN 50, PN 16		
	35G = 30 - 300 GPM	G9 = 2" ANSI 150 lb		
	40H = 13.5 - 135 m ³ /h	FB = DN 80, PN 16		
	40G = 60 - 600 GPM	AB = 3" ANSI 150 lb		
	45H = 27 - 270 m ³ /h	FC = DN 100, PN 16		
	45G = 120 - 1200 GPM	AC = 4" ANSI 150 lb		
50H = 55 - 550 m ³ /h	FE = DN 150, PN 16			
50G = 240 - 2400 GPM	AE = 6" ANSI 150 lb			
XXH = special option	XX = special option	XX = special option		

* Change DOT-xxxFx... into DOT-xxxHx... for PN25
 Change DOT-xxxAx... into DOT-xxxBx... for ANSI 300 RF

Dimensions [±2 mm]

Threaded

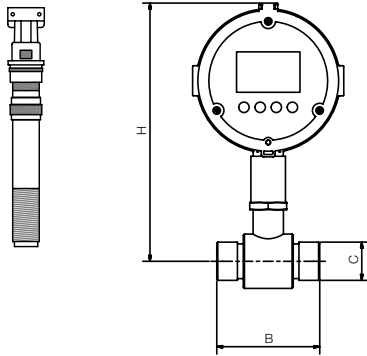

Flow [m³/h]	C (Thread)	B	H (with pulse output)	H (with ZOK/ZOE electronics)
0.11-1.1	½"	64	150	222
0.22-2.2	¾"	65	152	222
0.4-4	¾"	65	152	222
0.8-8	¾"	83	154	223
1.6-16	1"	89	158	226
3.4-34	1½"	114	164	233
6.8-68	2"	133	169	237

Flanged

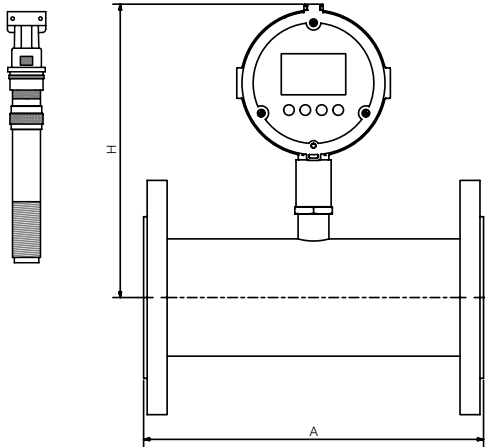

Flow [m³/h]	A	H (with pulse output)	H (with ZOK/ZOE electronics)
0.11-1.1	127	150	219
0.22-2.2	127	152	219
0.4-4	127	152	219
0.8-8	140	154	222
1.6-16	152	158	228
3.4-34	178	164	231
6.8-68	197	169	237
13.5-135	254	178	249
27-270	356	197	268
55-550	368	222	298

Clamp ferrule (Tri-Clamp®) (according to DIN 32676)

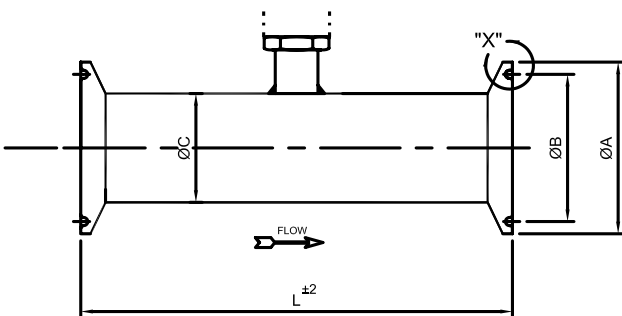

Model	±0.1 ØA	±0.1 ØB	±0.025 ØC	±0.1 F	±2 L
DOT-1305	50.5	43.5	31.7	2.85	127
DOT-1310	50.5	43.5	31.7	2.85	127
DOT-1315	50.5	43.5	31.7	2.85	127
DOT-1320	50.5	43.5	35.0	2.85	140
DOT-1325	50.5	43.5	38.1	2.85	152
DOT-1330	50.5	43.5	57.2	2.85	178
DOT-1335	64.0	56.3	69.5	2.85	197

Detail »X«

